



DCS GUIDE

F-86F SABRE

BY CHUCK
LAST UPDATED: 6/01/2023

SERIES 35

TABLE OF CONTENTS

- PART 1 - INTRODUCTION
- PART 2 – CONTROLS SETUP
- PART 3 – COCKPIT
- PART 4 – START-UP
- PART 5 – TAKEOFF
- PART 6 – LANDING
- PART 7 – ENGINE & FUEL MANAGEMENT
- PART 8 – AIRCRAFT LIMITATIONS
- PART 9 – AIRCRAFT OPERATION
- PART 10 – WEAPONS
- PART 11 – SKINS
- PART 12 – AN/ARC-27 UHF RADIO TUTORIAL
- PART 13 – NAVIGATION
- PART 14 – AN/APX-6 TRANSPONDER (IFF)
- PART 15 – TACTICS AGAINST THE MIG-15BIS
- PART 16 – OTHER RESOURCES

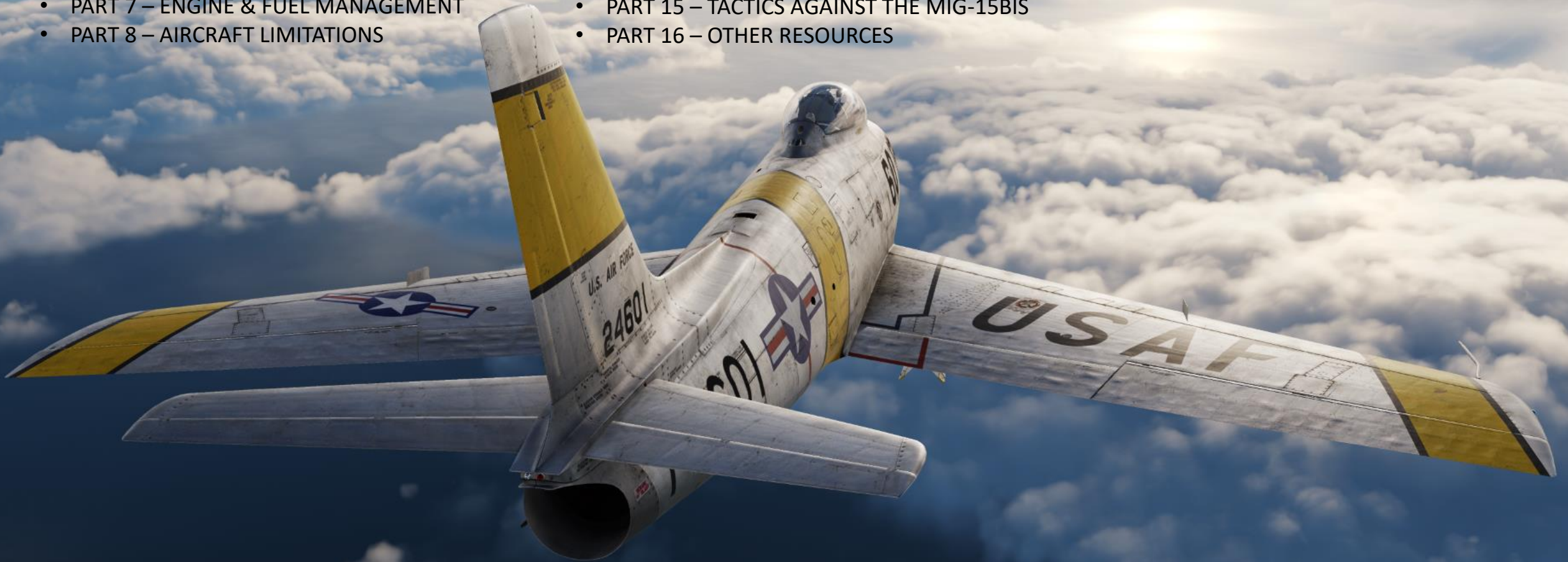

The **North American F-86 Sabre**, sometimes called the Sabrejet, is a transonic jet fighter aircraft. Produced by North American Aviation, the Sabre is best known as the United States' first swept-wing fighter that could counter the swept-wing Soviet MiG-15 in high-speed dogfights in the skies of the Korean War (1950–1953), the Taiwan crisis of 1958, and the Indo-Pakistani conflict of 1965. The Sabre fought some of the earliest jet-to-jet battles in history. Considered one of the best and most important fighter aircraft in that war, the F-86 is also rated highly in comparison with fighters of other eras. Although it was developed in the late 1940s and was outdated by the end of the 1950s, the Sabre proved versatile and adaptable and continued as a front-line fighter in numerous air forces.

The history of the F-86 started in autumn 1944 with the North American NA-134 naval fighter. By that time, North American was already a well-established aviation manufacturer, which had produced thousands of World War II fighter aircraft such as the P-51 Mustang. The NA-134 had a low straight wing and a short barrel-shaped fuselage. The TG180 turbojet engine with a thrust of 1,820 kgf gave the 6,532 kg fighter a maximum speed of 872 km/h. In addition, the NA-134 had a rate of climb of 23.8 m/s at sea level, and an operating ceiling of 14,500 m.

With these performances, this aircraft became a serious opponent in the air. But the required speed of 600 mph (960 km/h) was not achieved. The work continued. In May 1945, North American received an order from the United States Army Air Forces (USAAF) for three experimental NA-140s, each given the XP-86 designation. However, the aircraft still would not be able to meet the required top speed, so the management considered canceling the program. The main distinctions of the NA-140 from the NA-134 were an extended fuselage and a new wing design. The shape of the air intake was also modified, but the empennage was kept unchanged. Besides aerodynamic modifications, some special features arose from the project that had not been used on American fighters before – a pressurized cockpit and boosters in the pitch and roll control channels.

North American had to quickly devise a radical change that could leapfrog its rivals. The North American F-86 Sabre was the first American aircraft to take advantage of flight research data seized from the German aerodynamicists at the end of World War II. These data showed that a thin, swept wing could greatly reduce drag and delay compressibility problems that had bedeviled fighters such as the Lockheed P-38 Lightning when approaching the speed of sound. By 1944, German engineers and designers had established the benefits of swept wings based on experimental designs dating back to 1940. A study of the data showed that a swept wing would solve their speed problem, while a slat on the wing's leading edge that extended at low speeds would enhance low-speed stability.



North American NA-134



North American XP-86 Prototype

The XP-86, an unarmed prototype, was equipped with the Chevrolet J35-C-3 engine that produced 1,816 kgf of thrust. In August 1945, aerodynamicist Raymond Rayet suggested testing a swept-wing XP-86 model in the wind tunnel. The tests started in September and immediately showed a lower drag and a larger maximum airspeed. In November 1945, the project was approved. The wing received a 35° sweepback and slats were installed. The slats would automatically extend at 130 knots and retract at 290 knots solving the problem of low-speed instability. The first swept-wing XP-86 had its first flight on October 1, 1947.

The project began active development and was so successful that in December 1947, the U.S. Air Force signed a contract for the F-86A (company designation NA-151) fitted with the General Electric J47-GE-7 engine, and – later on – with the improved J47-GE-13 engine. The aircraft received an armament of six 12.7 mm machine guns. Also, instead of jettisonable tanks, it could carry external stores. These usually took the form of 45 kg, 220 kg, 454 kg bombs, 375 kg tanks with napalm, or 220 kg expendable bomb cells. Tracks for eight unguided rockets could also be installed under each wing.

Work on the F-86F Sabre started in July 1950. An order for 109 aircraft was signed in April 1951. In June, the order was extended to 360 aircraft. F-86F production took place at two manufacturing plants: in Inglewood where Sabrejets were built and at the facility in Columbus that had been preserved from the end of World War II. With the more powerful J47-GE-27 engine, the new model had significantly better performance characteristics. The top speed of the F-86F increased to 1,107 km/h at sea level and to 965 km/h at an altitude of 10,670 m. The operating ceiling also increased to 14,500 m. Finally, a better engine efficiency extended the fighter's combat radius to 690 km.

The first F-86Fs were assembled in Inglewood. Deliveries of the J47-GE-27 jet engine started in spring 1952, and then, on March 19, the first F-86F-1 airframe out of 78 was built. In June, the F-86F-5 modification came out that could carry external fuel tanks of 760-liter capacity instead of the previous 454 liters. This extended the fighter's combat radius to 740 km. The development of the next variant of the F-86F Sabre started in October 1951. The project was a fighter-bomber modification designated NA-191. On each wing, the aircraft had two pylons instead of one. Previous Sabrejet modifications were not very suitable for bombing because of their short range if the fuel tanks were replaced with bombs or missiles. With four attachments for external stores, this aircraft could carry 454-liter tanks or 454 kg bombs on the inner pylons, and 760-liter tanks on the outer pylons. With the maximum fuel reserve (i.e. with two 760-liter and two 454-liter tanks), the ferry range reached 2,560 km while the combat radius increased to 910 km.



The Sabre's swept wings and jet engine produced a flying experience that was very different from the propeller-driven fighters of the time. The transition from props to jets was not without accidents and incidents even for experienced fighter pilots. Early on in the jet age, some US manufacturers instituted safety and transition programs where experienced test and production pilots toured operational fighter squadrons to provide instruction and demonstrations designed to lower the accident rate.

Additionally, the ongoing technical development and long production history of the F-86 resulted in some significant differences in the handling and flying characteristics between the various F-86 models. Some of the important changes to the design included the switch from an elevator/stabilizer to an all-flying tail, the discontinuation of leading edge slats for a solid leading edge with increased internal fuel capacity, increased engine power, and an internal missile bay (F-86D).

Each of these design changes impacted the handling and flying characteristics of the F-86, not necessarily for the better. In the case of the solid leading edge and increased internal fuel capacity, the design change produced increased combat performance but exacerbated a dangerous and often fatal handling characteristic upon take-off if the nose were raised prematurely from the runway. This 'over-rotation' danger is now a major area of instruction and concern for current F-86 pilots. The 1972 Sacramento Canadair Sabre accident resulting in 22 fatalities and 28 other casualties was a result of over-rotation on take-off.



Its success led to an extended production run of more than 7,800 aircraft between 1949 and 1956, in the United States, Japan, and Italy. In addition, 738 carrier-modified versions were purchased by the US Navy as FJ-2s and -3s. Variants were built in Canada and Australia. The F-86 was also manufactured by Canadair in Canada as the CL-13 Sabre to replace its de Havilland Vampires. The Canadair Sabre added another 1,815 aircraft and the significantly redesigned CAC Sabre (sometimes known as the Avon Sabre or CAC CA-27), had a production run of 112. The Sabre is by far the most-produced Western jet fighter, with a total production of all variants at 9,860 units.



In the early 1950s, a nuclear weapon was considered a super weapon that could guarantee a quick victory in a war. Nuclear bombs were designed to be delivered to the target by any means. The first fighter-bomber modification capable of carrying a nuclear bomb was the F-86F-35, which is the variant simulated in DCS.

The Sabre is best known for seeing action in the Korean War against the MiG-15 (1950-1953). It was at this time that the famous “MiG Alley” was born. This term referred to the region in the north-western part of North Korea, south of the Yalu Jiang River, which separates North Korea and China. This area was controlled by the MiGs and it was dangerous for the Allies to fly there. All air combat over MiG Alley was short as the great distance from the Sabres’ home bases limited their time in this region. By the end of the Korean War, the US awarded almost 800 aerial victory credits to Sabre pilots, while losing less than eighty F-86s, although Soviet and Chinese records challenge these numbers.

Famous aces of the Korean War include Captain Joseph C. McConnell, Captain Manuel J. “Pete” Fernandez and Major Frederick C. “Boots” Blesse, who pioneered jet air combat tactics in his textbook “No Guts, No Glory.”



Captain Joseph C. McConnell
16 Victories



Captain Manuel J. "Pete" Fernandez
14.5 Victories (1 Shared)



Major Frederick C. "Boots" Blesse
10 Victories



Overall, I think the DCS F-86F Sabre is a real gem. Dogfighting at speeds over 400 knots against MiG-15s is a unique experience that gives you a WWII-style air combat at breakneck speeds. It is a product of a time when fighter jet combat was still in its infancy, and aircraft design was still evolving at an unprecedented pace. The 1950s have a special place in my heart when it comes to aircraft design due to the sheer variety of outlandish designs. Most aircraft of the time looked aggressive, dangerous and experimental in nature.

I hope you will enjoy reading this guide as much as I had fun writing it. So, put on those aviator sunglasses, crank the time machine and let's learn the Sabre together!



WHAT YOU NEED MAPPED

A-4 Sight Electrical Caging Button (On Throttle)
(Grey button on RHS)

Weapon Release
(RALT+SPACE)

First Stage: Trigger – First Detent (LSHIFT+SPACE)
Second Stage: Trigger – Second Detent (SPACE)

↑
↓
←
→
P A-4 Sight Radar Target Selector Button

Nosewheel Steering Button

↑ Trim Down
→ Trim Right
↓ Trim Up
← Trim Left

↑ Zoom In Slow
→
↓ Zoom Out Slow
←

↑ A-4 Sight Man Ranging (Throttle Twist Grip) CCW/Increase
→ A-4 Sight Wingspan Adjustment - Increase
↓ A-4 Sight Man Ranging (Throttle Twist Grip) CW/Decrease
← A-4 Sight Wingspan Adjustment - Decrease

↑ Microphone Button (RALT+ \backslash)
→
↓ Communication Menu (\backslash)
←

← Speed Brake Sw - OUT
→ Speed Brake Sw - IN

+ TOE BRAKES (MAPPED ON PEDALS)

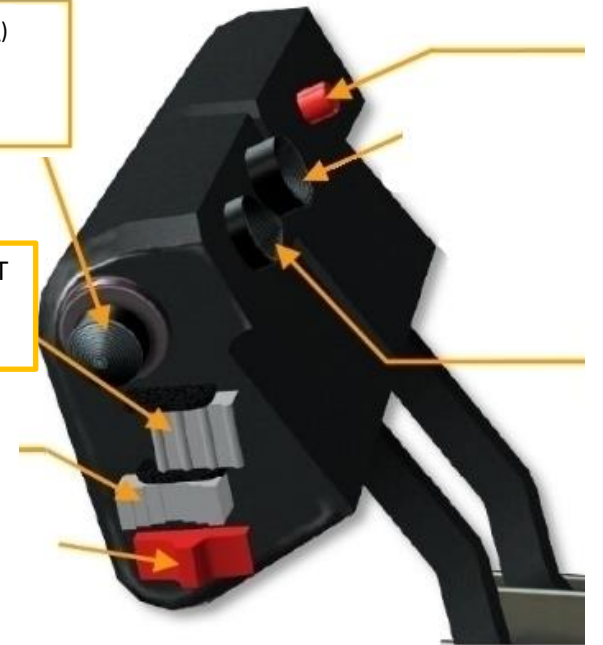

Note: In your controls, make sure you check your “Trim” controls since the default version of the game has your trim hat set to changing your view rather than trim the aircraft. Since most of you are probably equipped with a TRACKIR already, I suggest you make sure the Trim Hat Switch is set up properly.

CONTROL OPTIONS

F-86F Real | Axis Commands | Foldable view | Reset category to default | Clear category | Clear all | Load profile | Save profile as

Action	Category	Keyboard	Throttle - HOTAS Warthog...	Saitek Pro Flight Combat ...	Joystick - HOTAS Warthog ...	TrackIR	Mouse
A-4 Sight Reticle Dimmer Control	A-4 Sight						
Absolute Camera Horizontal View							
Absolute Camera Vertical View							
Absolute Horizontal Shift Camera View							
Absolute Longitude Shift Camera View							
Absolute Roll Shift Camera View							
Absolute Vertical Shift Camera View							
AN/ARC-27 UHF Audio Volume Knob	AN/ARC-27 UHF Radio, Ri						
AN/ARN-6 Audio Volume Control	AN/ARN-6 Radio Compass						
Bomb-Target Wind Control Knob	A-4 Sight, Center Pedesta						
Camera Horizontal View							MOUSE_X
Camera Roll View							
Camera Vertical View							MOUSE_Y
Camera Zoom View							MOUSE_Z
Cockpit Air Temperature Control Rheostat	Left Side Panel, Air Condit						
Console and Panel Light Rheostat	Interior Light Control Pane						
G-Limit Indicator Light Brightness	Missile Control Panel, Arm						
Head Tracker : Forward/Backward						TRACKIR_Z	
Head Tracker : Pitch						TRACKIR_PITCH	
Head Tracker : Right/Left						TRACKIR_X	
Head Tracker : Roll						TRACKIR_ROLL	
Head Tracker : Up/Down						TRACKIR_Y	
Head Tracker : Yaw						TRACKIR_YAW	
Instrument Panel Auxiliary Light Rheostat	Interior Light Control Pane						
Instrument Panel Primary Light Rheostat	Interior Light Control Pane						
J-8 Attitude Indicator Pitch Trim Knob	Instrument Panel						
Manual Pip Control Knob	Manual Pip Control Panel						
Manual Range	A-4 Sight, Throttle Grip		JOY_SLIDER1				
Missile Tone Volume	Missile Control Panel, Arm						
Oxygen Regulator Supply Lever	Oxygen Regulator Panel						
Pitch	Flight Control					JOY_Y	
Roll	Flight Control					JOY_X	
Rudder	Flight Control				JOY_RZ		
TDC Slew Horizontal (mouse)							
TDC Slew Vertical (mouse)							
Thrust	Flight Control		JOY_Z				
Wheel Brake	Gear Systems						
Wheel Brake Left	Gear Systems				JOY_X		
Wheel Brake Right	Gear Systems				JOY_Y		
Wing Span	A-4 Sight						
Zoom View							

Modifiers | Add | Clear | Default | Axis Assign | Axis Tune | FF Tune | Make HTML | Disable hot plug | Rescan devices

CANCEL | OK

10

To assign axis, click on Axis Assign. You can also select “Axis Commands” in the upper scrolling menu.

To modify curves and sensitivities of axes, click on the axis you want to modify and then click on “Axis Tune”.



F-86F
SABRE

PART 2 – CONTROLS SETUP

Bind the following axes:

- PITCH (DEADZONE AT 5, SATURATION X AT 100, SATURATION Y AT 100, CURVATURE AT 20)
- ROLL (DEADZONE AT 5, SATURATION X AT 100, SATURATION Y AT 100, CURVATURE AT 20)
- RUDDER (DEADZONE AT 0, SATURATION X AT 100, SATURATION Y AT 100, CURVATURE AT 0)
- THROTTLE – CONTROLS ENGINE RPM
- WHEEL BRAKE LEFT
- WHEEL BRAKE RIGHT

When setting wheel brake axis, the axis is not set to “Invert” by default. You need to click on “Invert” in the Axis Tune Menu for each wheel brake.

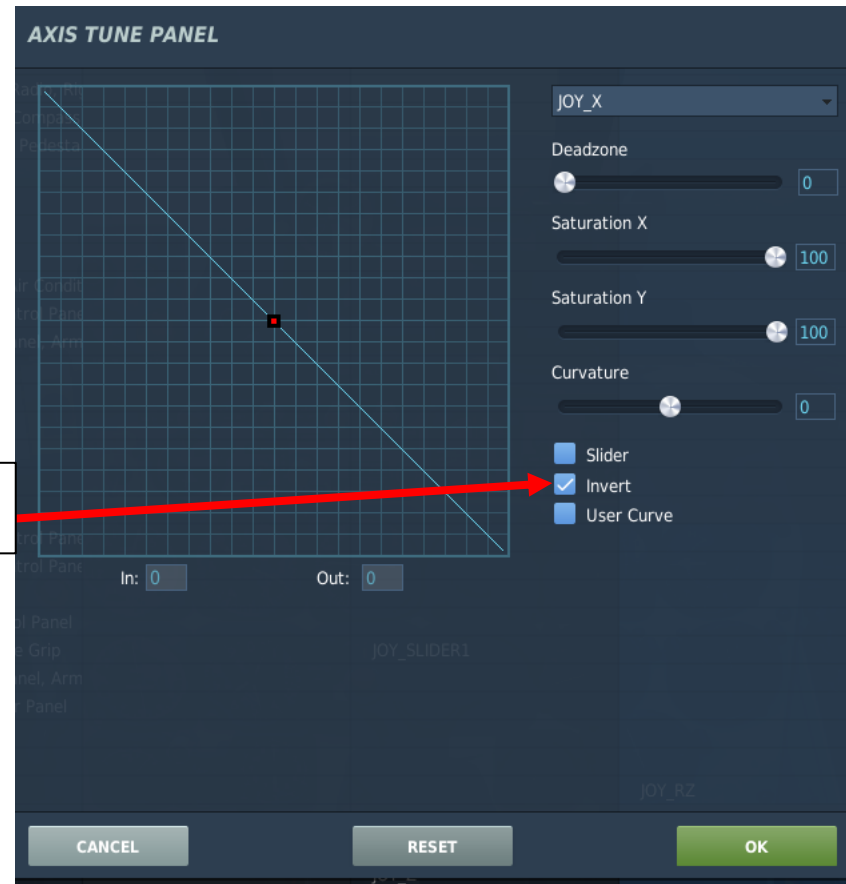





Tip: Pilot body can be toggled ON/OFF with "RSHIFT+P"

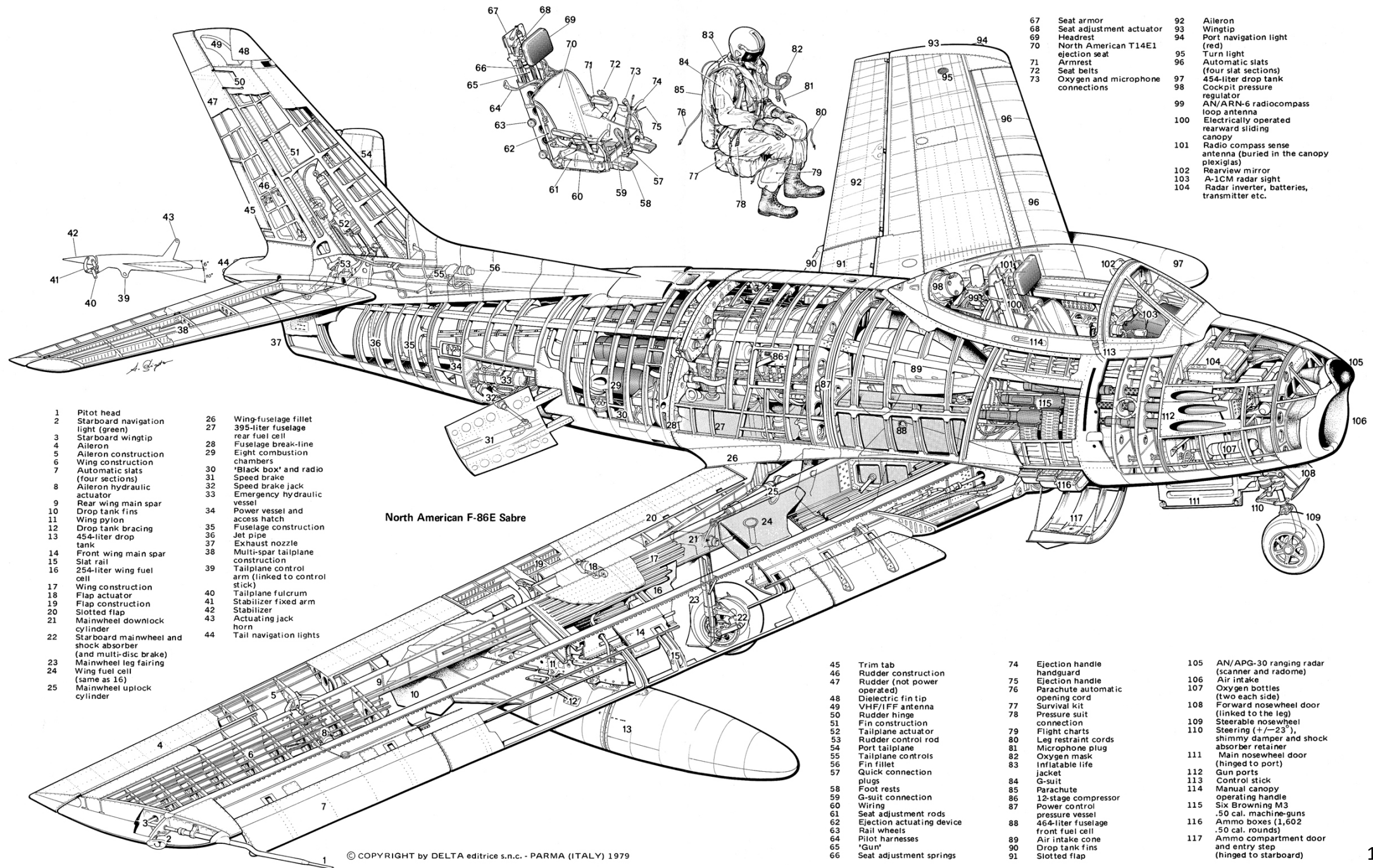

© COPYRIGHT by DELTA editrice s.n.c. - PARMA (ITALY) 1979

- 1 Pitot head
- 2 Starboard navigation light (green)
- 3 Starboard wingtip
- 4 Aileron
- 5 Aileron construction
- 6 Wing construction
- 7 Automatic slats (four sections)
- 8 Aileron hydraulic actuator
- 9 Rear wing main spar
- 10 Drop tank fins
- 11 Wing pylon
- 12 Drop tank bracing
- 13 454-liter drop tank
- 14 Front wing main spar
- 15 Slat rail
- 16 254-liter wing fuel cell
- 17 Wing construction
- 18 Flap actuator
- 19 Flap construction
- 20 Slotted flap
- 21 Mainwheel downlock cylinder
- 22 Starboard mainwheel and shock absorber (and multi-disc brake)
- 23 Mainwheel leg fairing
- 24 Wing fuel cell (same as 16)
- 25 Mainwheel uplock cylinder
- 26 Wing-fuselage fillet
- 27 395-liter fuselage rear fuel cell
- 28 Fuselage break-line
- 29 Eight combustion chambers
- 30 'Black box' and radio
- 31 Speed brake
- 32 Speed brake jack
- 33 Emergency hydraulic vessel
- 34 Power vessel and access hatch
- 35 Fuselage construction
- 36 Jet pipe
- 37 Exhaust nozzle
- 38 Multi-spar tailplane construction
- 39 Tailplane control arm (linked to control stick)
- 40 Tailplane fulcrum
- 41 Stabilizer fixed arm
- 42 Stabilizer
- 43 Actuating jack horn
- 44 Tail navigation lights

North American F-86E Sabre

- 45 Trim tab
- 46 Rudder construction
- 47 Rudder (not power operated)
- 48 Dielectric fin tip
- 49 VHF/IFF antenna
- 50 Rudder hinge
- 51 Fin construction
- 52 Tailplane actuator
- 53 Rudder control rod
- 54 Port tailplane
- 55 Tailplane controls
- 56 Fin fillet
- 57 Quick connection plugs
- 58 Foot rests
- 59 G-suit connection
- 60 Wiring
- 61 Seat adjustment rods
- 62 Ejection actuating device
- 63 Rail wheels
- 64 Pilot harnesses
- 65 'Gun'
- 66 Seat adjustment springs

- 74 Ejection handle handguard
- 75 Ejection handle
- 76 Parachute automatic opening cord
- 77 Pressure suit connection
- 78 Flight charts
- 79 Leg restraint cords
- 80 Microphone plug
- 81 Oxygen mask
- 82 Inflatable life jacket
- 83 G-suit
- 84 Parachute
- 85 12-stage compressor
- 86 Power control pressure vessel
- 87 464-liter fuselage front fuel cell
- 88 Air intake cone
- 89 Drop tank fins
- 90 Slotted flap

- 67 Seat armor
- 68 Seat adjustment actuator
- 69 Headrest
- 70 North American T14E1 ejection seat
- 71 Armrest
- 72 Seat belts
- 73 Oxygen and microphone connections

- 92 Aileron
- 93 Wingtip
- 94 Port navigation light (red)
- 95 Turn light
- 96 Automatic slats (four slat sections)
- 97 454-liter drop tank
- 98 Cockpit pressure regulator
- 99 AN/ARN-6 radiocompass loop antenna
- 100 Electrically operated rearward sliding canopy
- 101 Radio compass sense antenna (buried in the canopy plexiglas)
- 102 Rearview mirror
- 103 A-1CM radar sight
- 104 Radar inverter, batteries, transmitter etc.

- 105 AN/APG-30 ranging radar (scanner and radome)
- 106 Air intake
- 107 Oxygen bottles (two each side)
- 108 Forward nosewheel door (linked to the leg)
- 109 Steerable nosewheel
- 110 Steering (+/-23°), shimmy damper and shock absorber retainer
- 111 Main nosewheel door (hinged to port)
- 112 Gun ports
- 113 Control stick
- 114 Manual canopy operating handle
- 115 Six Browning M3 .50 cal. machine-guns
- 116 Ammo boxes (1,602 .50 cal. rounds)
- 117 Ammo compartment door and entry step (hinged to starboard)





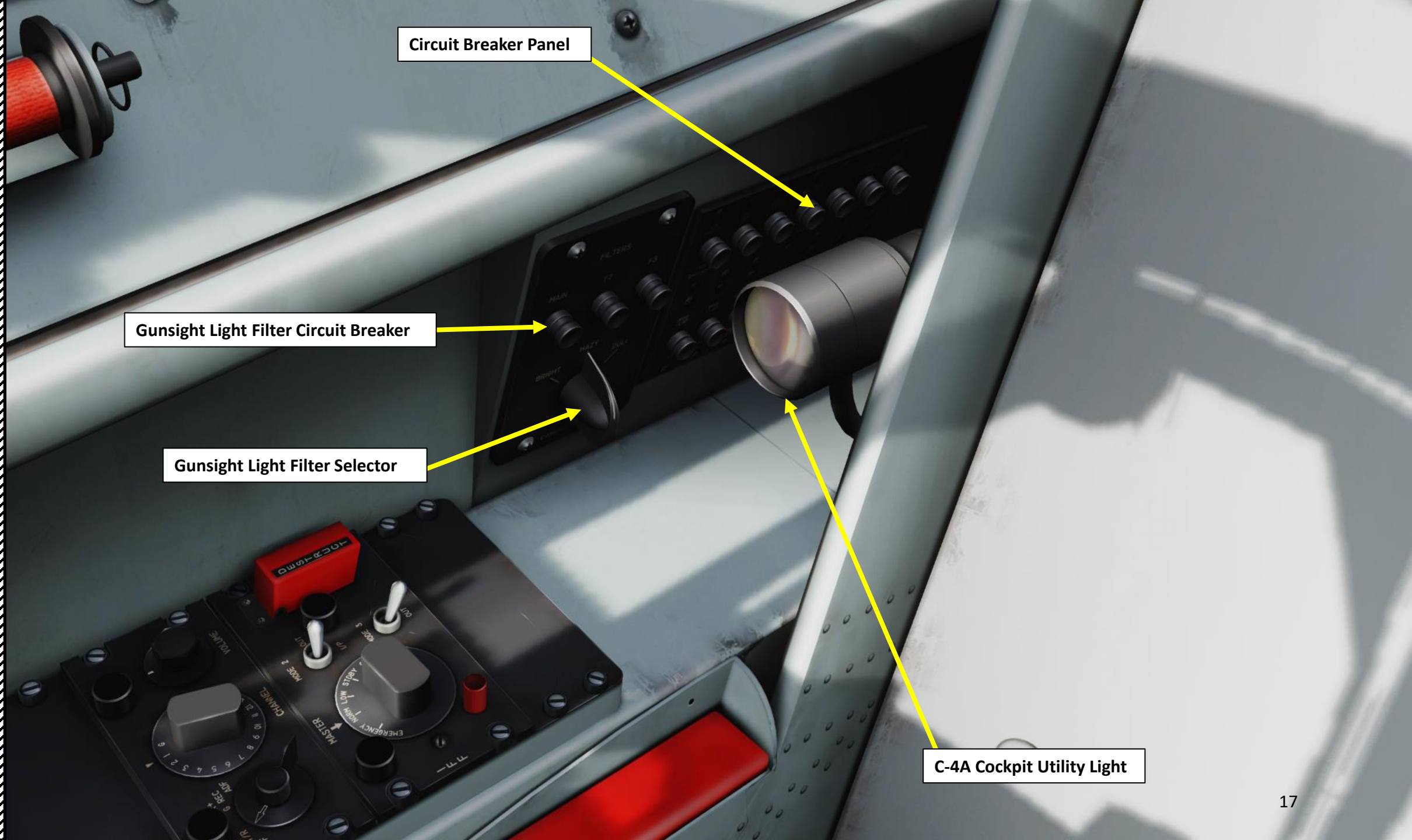

Circuit Breaker Panel

Gun Sight Light Filter Circuit Breaker

Gun Sight Light Filter Selector

C-4A Cockpit Utility Light

Canopy Breaker Tool (used to shatter glass, not simulated)

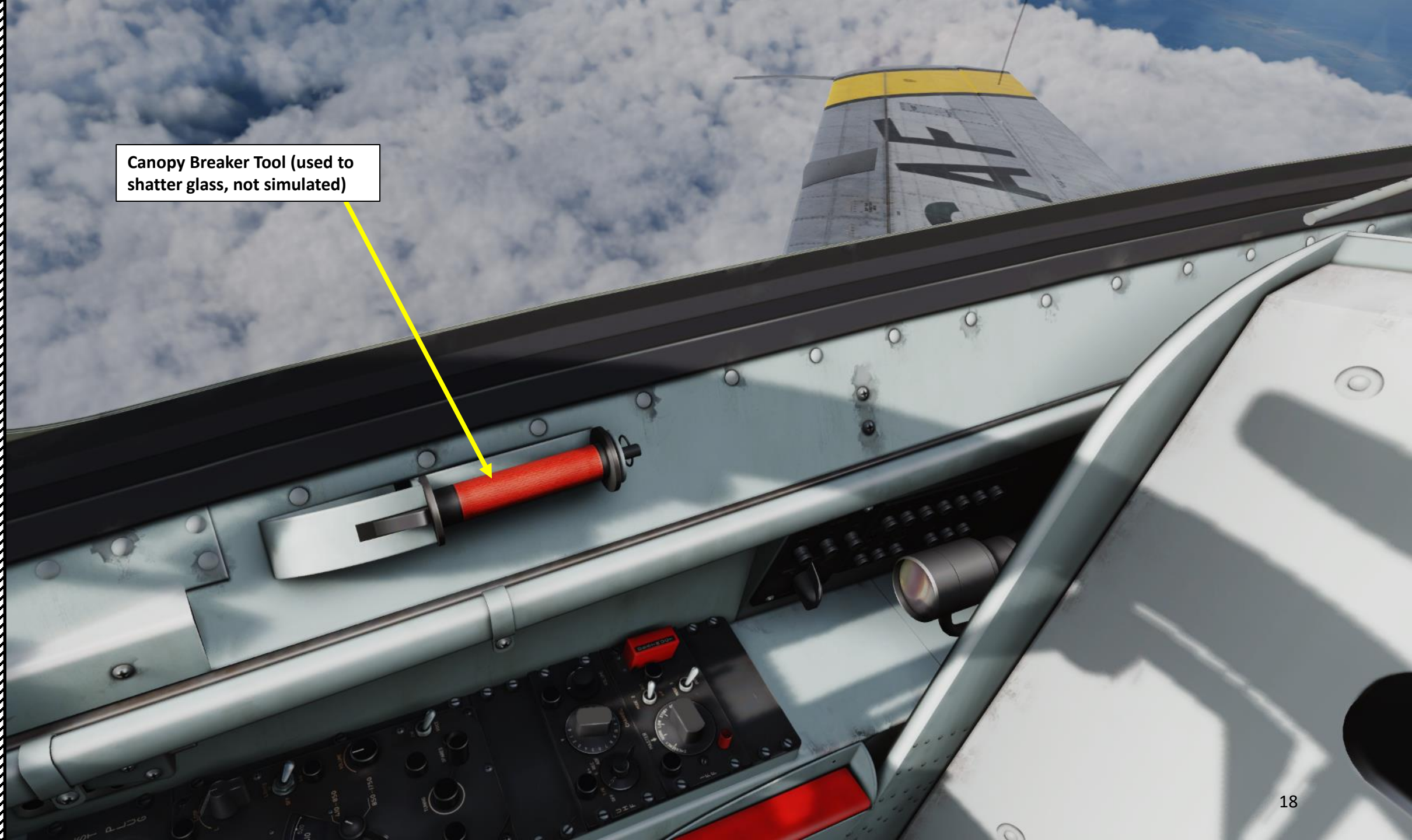



AN/ARC-27 UHF Radio

AN/APX-6 IFF (Identify-Friend-or-Foe) Transponder Panel



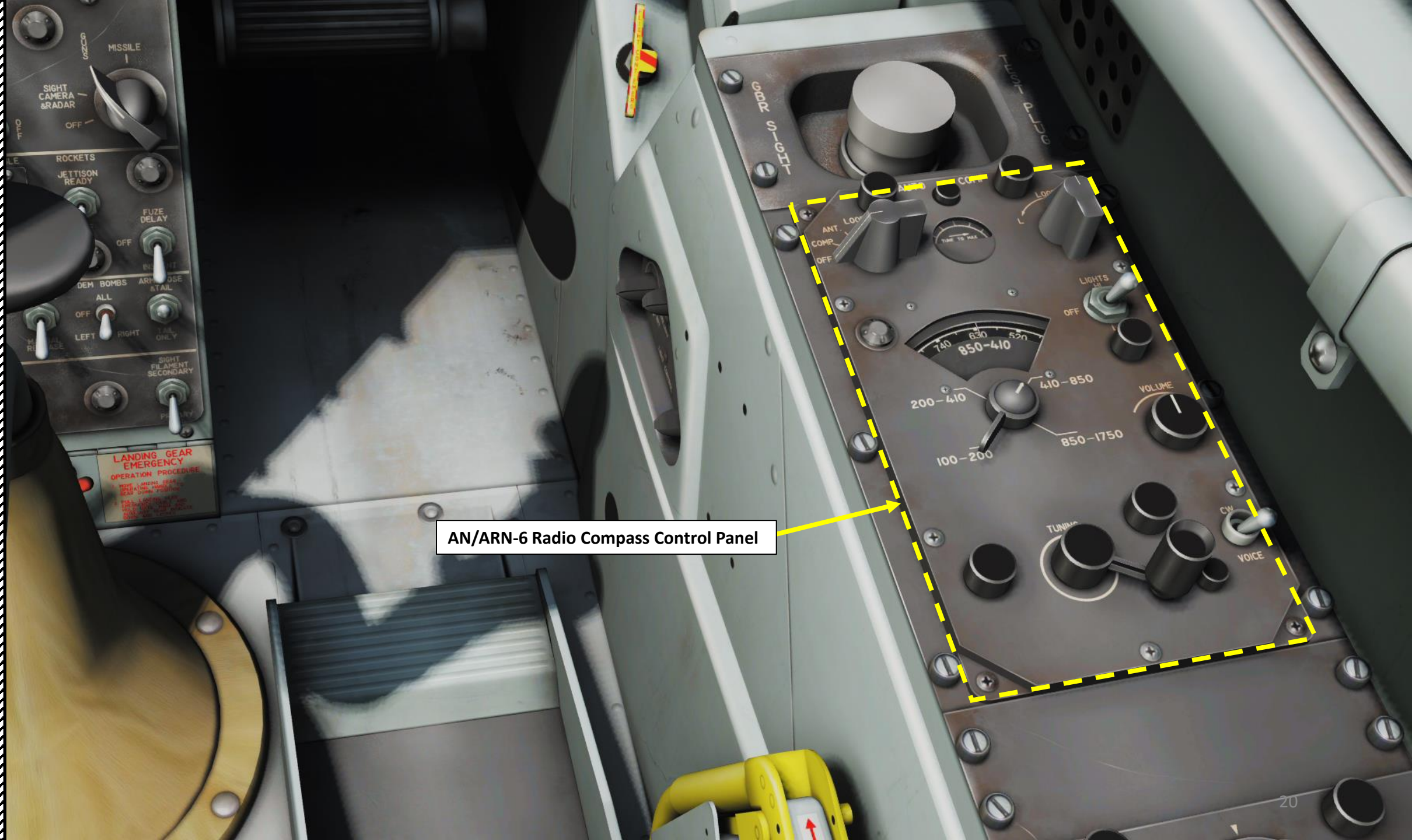

AN/ARN-6 Radio Compass Control Panel

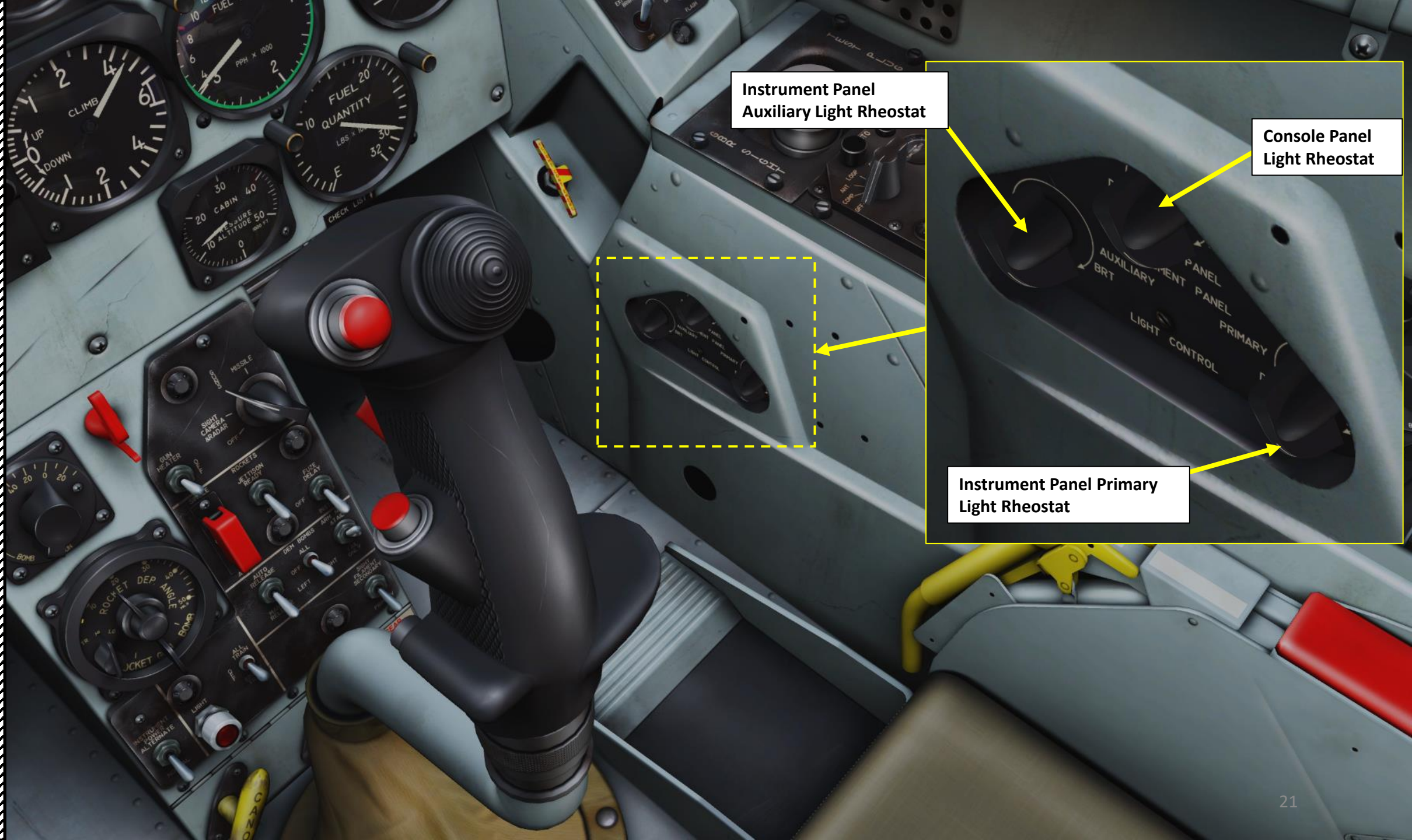

Instrument Panel
Auxiliary Light Rheostat

Console Panel
Light Rheostat

Instrument Panel Primary
Light Rheostat

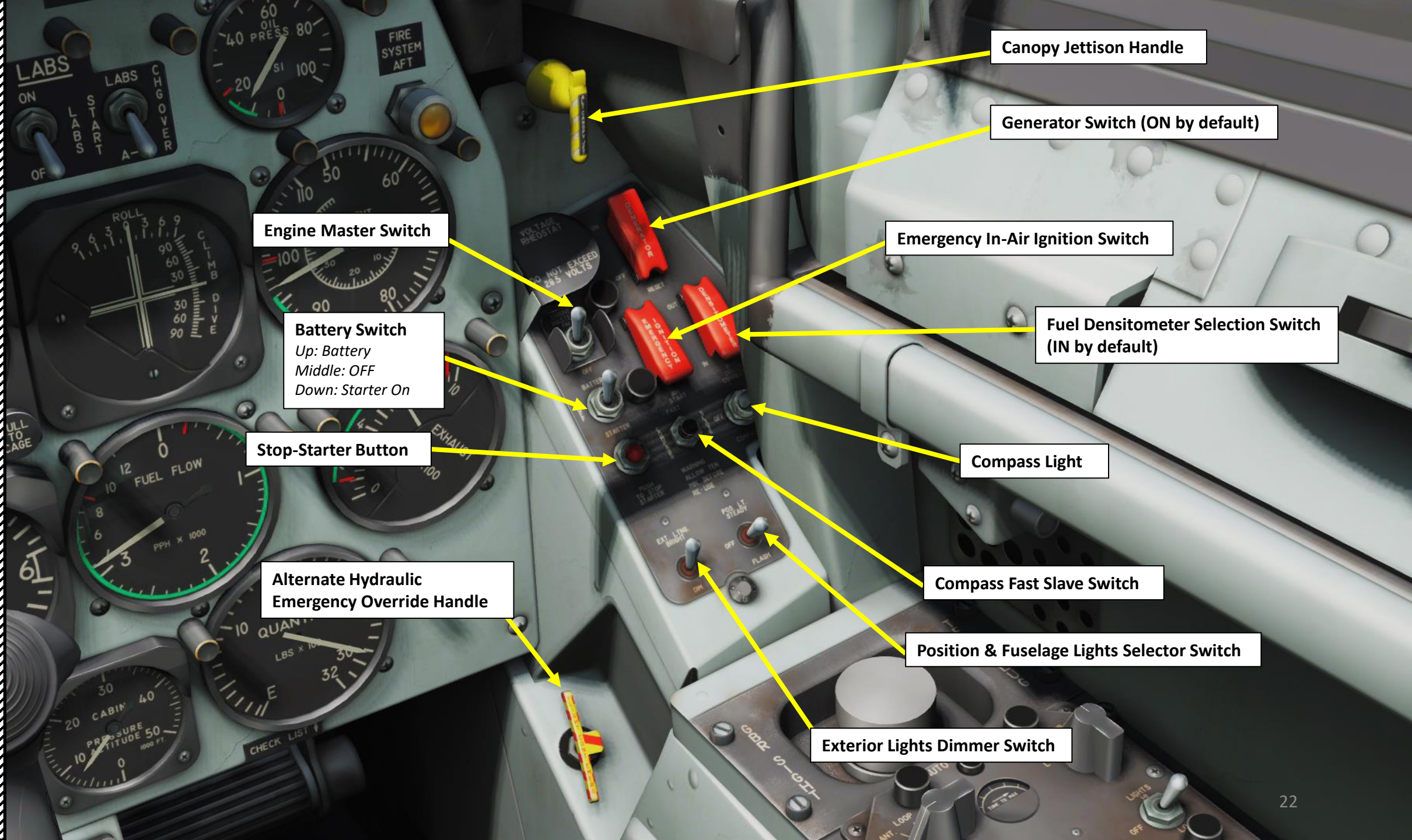

Canopy Jettison Handle

Generator Switch (ON by default)

Emergency In-Air Ignition Switch

Fuel Densitometer Selection Switch (IN by default)

Engine Master Switch

Battery Switch
Up: Battery
Middle: OFF
Down: Starter On

Stop-Starter Button

Compass Light

Alternate Hydraulic
Emergency Override Handle

Compass Fast Slave Switch

Position & Fuselage Lights Selector Switch

Exterior Lights Dimmer Switch



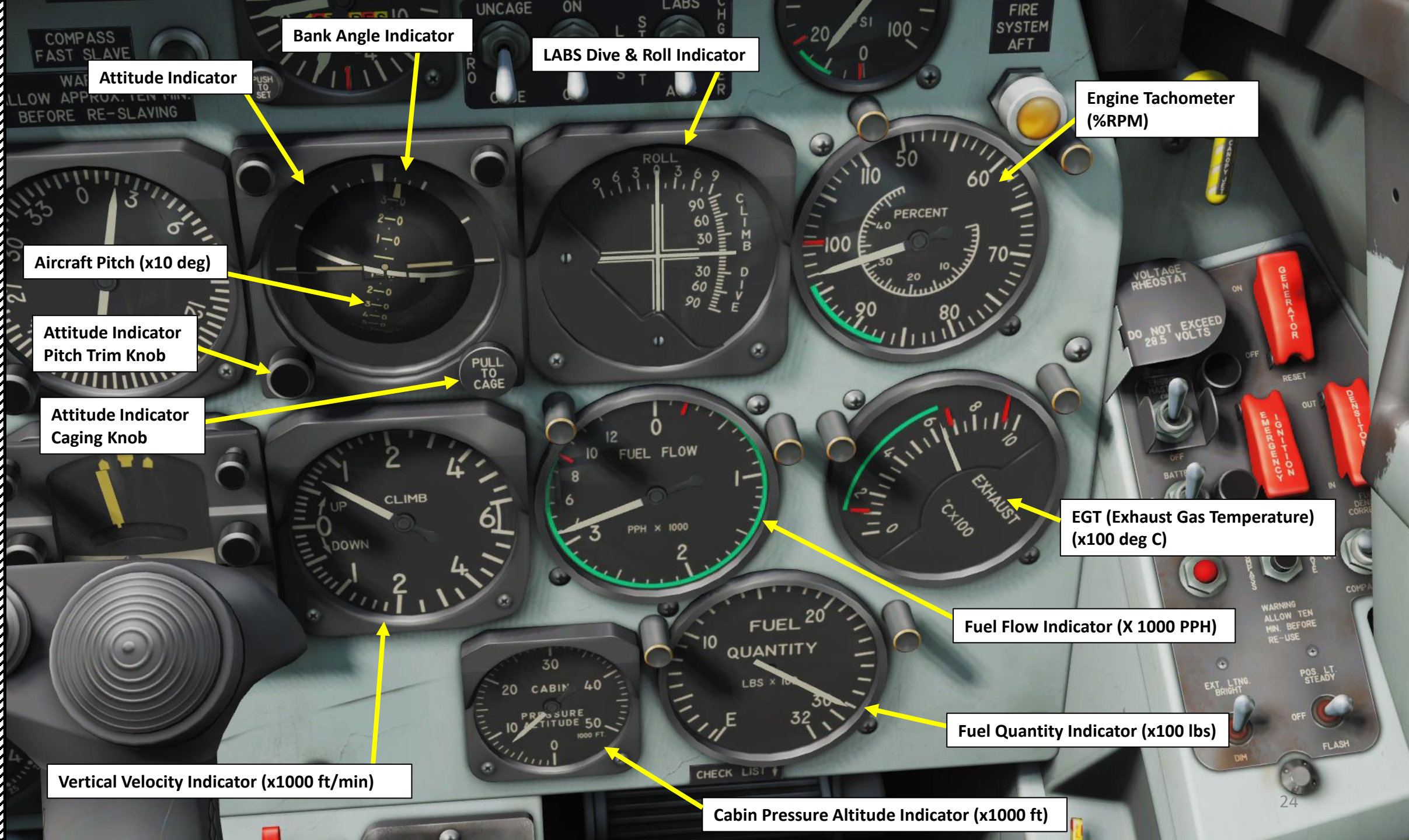

Bank Angle Indicator

LABS Dive & Roll Indicator

Attitude Indicator

Engine Tachometer (%RPM)

Aircraft Pitch (x10 deg)

Attitude Indicator Pitch Trim Knob

Attitude Indicator Caging Knob

EGT (Exhaust Gas Temperature) (x100 deg C)

Fuel Flow Indicator (X 1000 PPH)

Fuel Quantity Indicator (x100 lbs)

Vertical Velocity Indicator (x1000 ft/min)

Cabin Pressure Altitude Indicator (x1000 ft)

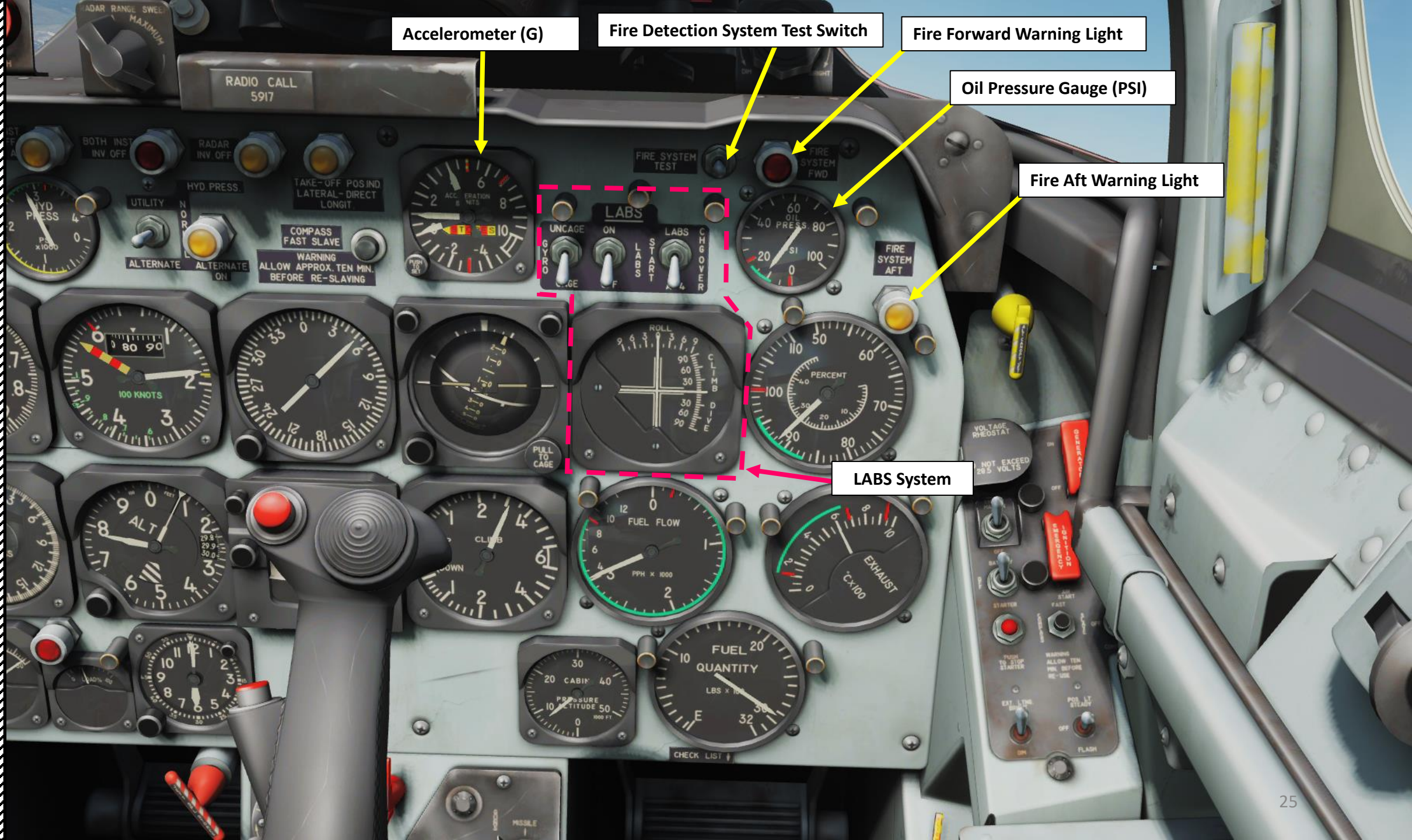

Accelerometer (G)

Fire Detection System Test Switch

Fire Forward Warning Light

Oil Pressure Gauge (PSI)

Fire Aft Warning Light

LABS System

Hydraulic Pressure Gauge (X1000 PSI)

Emergency Fuel Switch

Main Instrument (3-phase)
Inverter Failure Light

Both Instrument (3-phase)
Inverter Failure Light

Main Radar (single-phase)
Inverter Failure Light

Takeoff Trim Position Indicator
(Illuminates when trimmed for takeoff)

Magnetic Compass
Fast Slave Button

Alternate-On Warning Light
Flight control alternate hydraulic system is operating

Hydraulic Pressure Gauge Selector Switch
*UP: Utility Hydraulic System Pressure Selected
MIDDLE: Flight Control Normal Hydraulic System Pressure Selected
DOWN: Alternate Hydraulic System Pressure Selected*



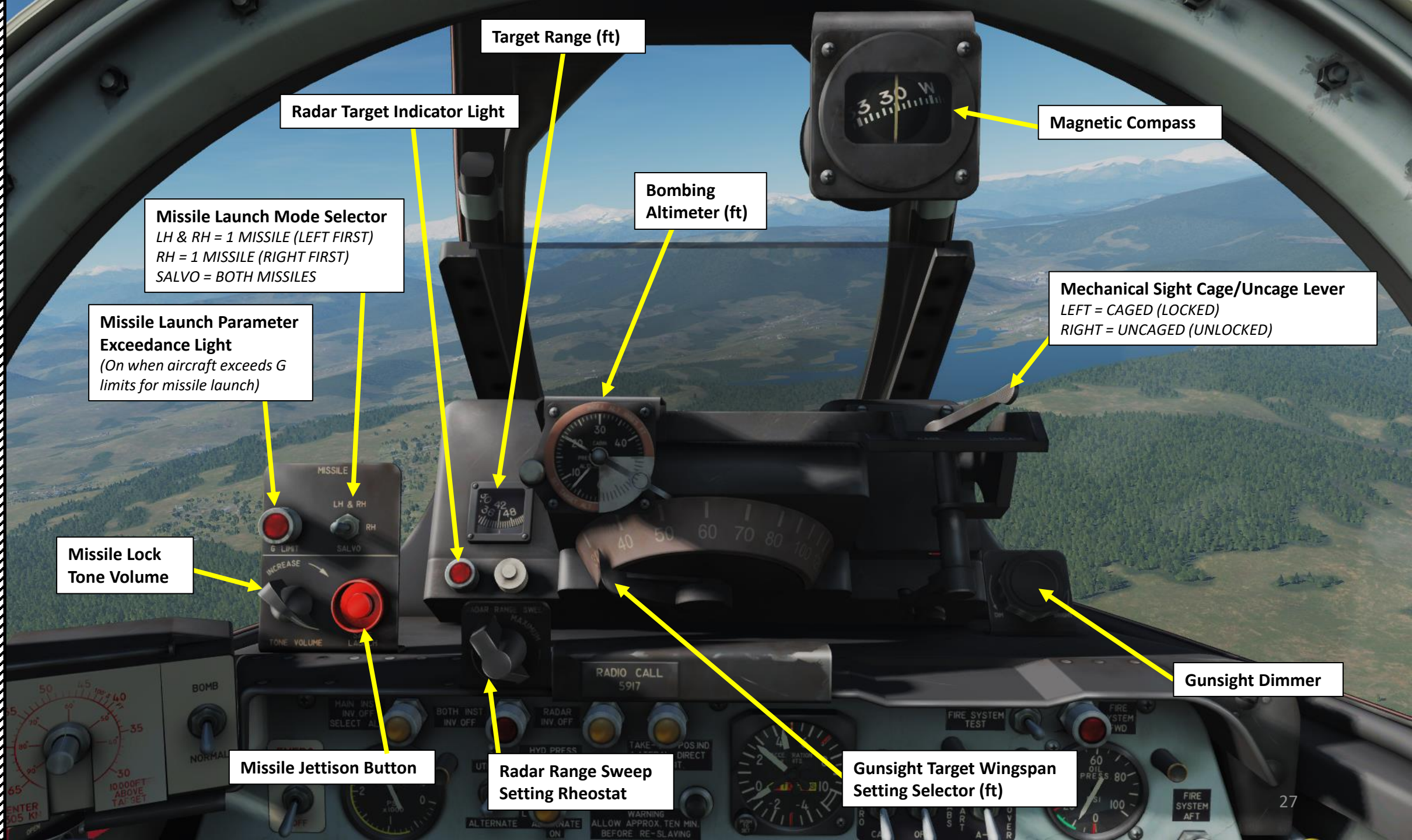

Target Range (ft)

Radar Target Indicator Light

Magnetic Compass

Bombing Altimeter (ft)

Missile Launch Mode Selector
LH & RH = 1 MISSILE (LEFT FIRST)
RH = 1 MISSILE (RIGHT FIRST)
SALVO = BOTH MISSILES

Mechanical Sight Cage/Uncage Lever
LEFT = CAGED (LOCKED)
RIGHT = UNCAGED (UNLOCKED)

Missile Launch Parameter Exceedance Light
(On when aircraft exceeds G limits for missile launch)

Missile Lock Tone Volume

Missile Jettison Button

Radar Range Sweep Setting Rheostat

Gunsight Target Wingspan Setting Selector (ft)

Gunsight Dimmer



Mirror

Bomb Target Wind Correction Setting (kts)

Rocket Depression Angle Selector (deg)

Gun Heater Switch

Bomb Drop Speed HI/LOW Selector

Weapon Selector

- **OFF:** all circuits supplying gunsight (gyro and backlight), camera, radar, gun firing, and missile launching are disabled
- **Sight Camera & Radar:** gunsight and camera operate in normal mode while gun firing and missile launching circuits are disabled
- **Guns:** gunsight and camera operate in normal mode, gun firing circuits are enabled, and missile launching circuits are disabled
- **Missile:** gunsight and camera operate in normal mode, missile launching circuits are enabled, and gun firing circuits are disabled

Gunsight Function Selector
Rocket/Gun/Bomb

Rocket Jettison "READY" Switch

Rocket Fuze Delay

Instrument Power Switch
Normal/Alternate

Bomb Fuze Delay (set to Nose & Tail by default)

Fragmentation Bombs Indicator Light
(not simulated)

Bomb Release Sequence Selector

Fragmentation Bomb Selector Switch
(not simulated since no fragmentation bombs are simulated for the F-86)

Rocket Release Mode Selector (Manual/Auto)

Bomb Release Mode Selector (Manual/Auto)

Gunsight Filament Selector

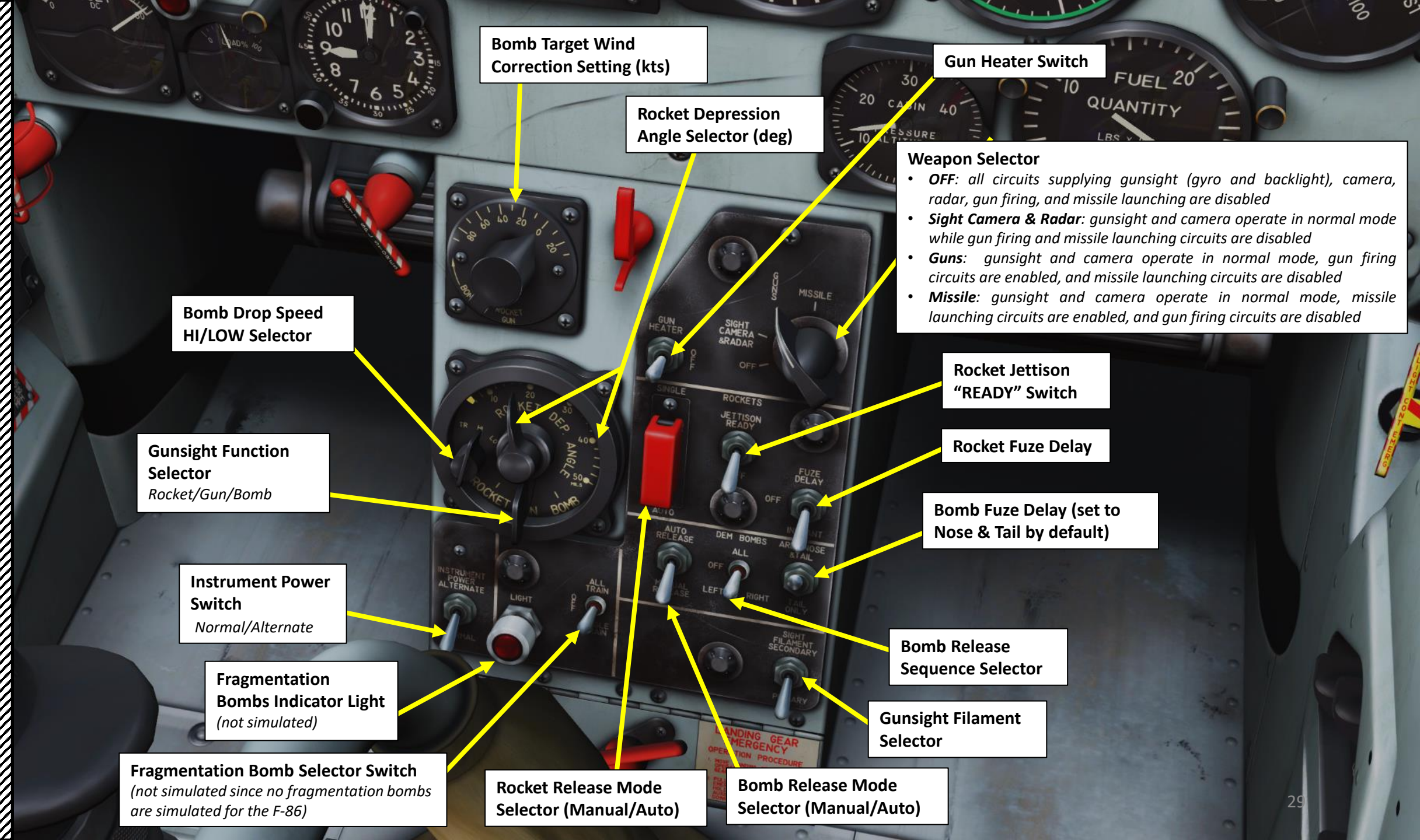

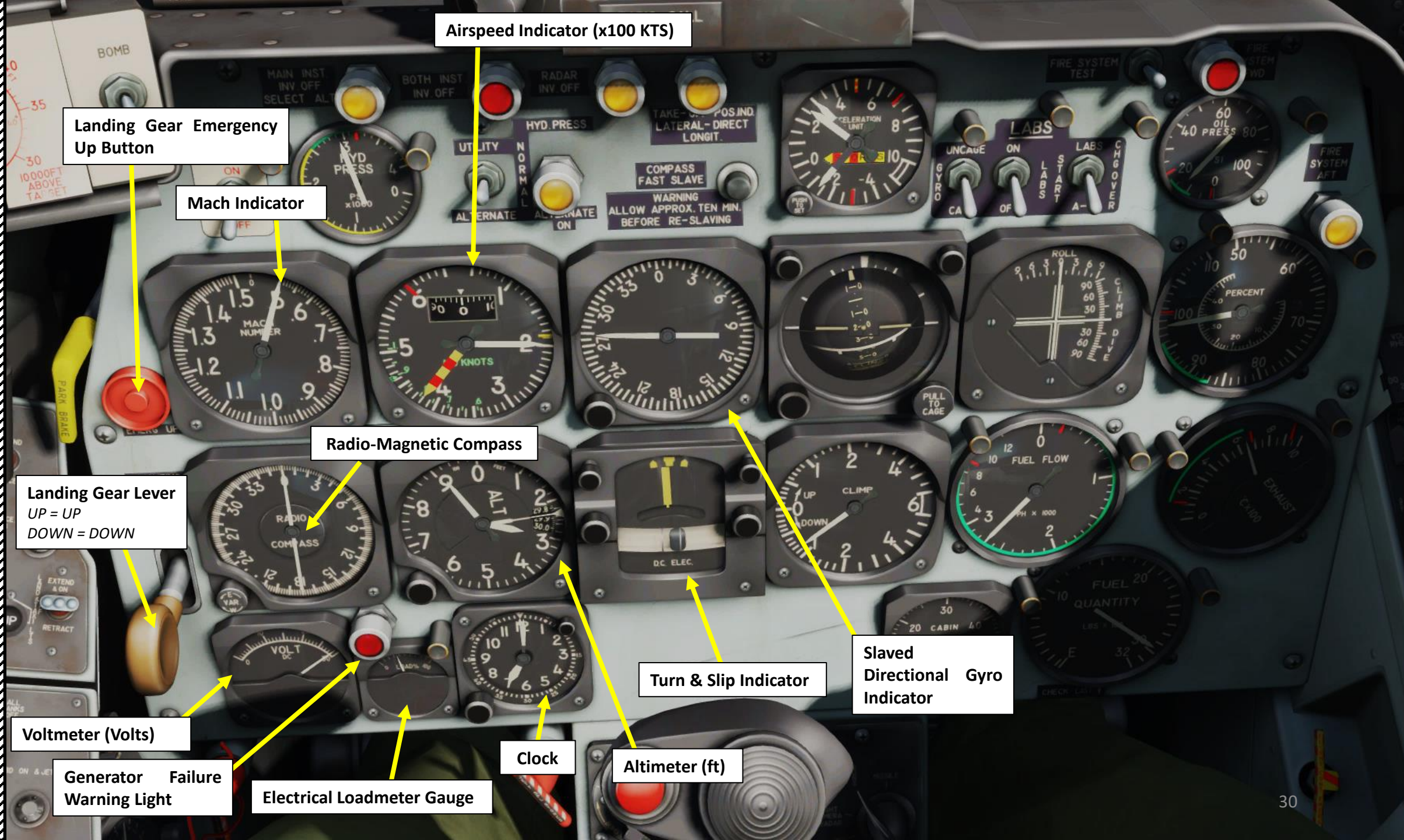

Landing Gear Emergency Up Button

Mach Indicator

Airspeed Indicator (x100 KTS)

Radio-Magnetic Compass

Landing Gear Lever
UP = UP
DOWN = DOWN

Voltmeter (Volts)

Generator Failure Warning Light

Electrical Loadmeter Gauge

Clock

Altimeter (ft)

Turn & Slip Indicator

Slaved Directional Gyro Indicator

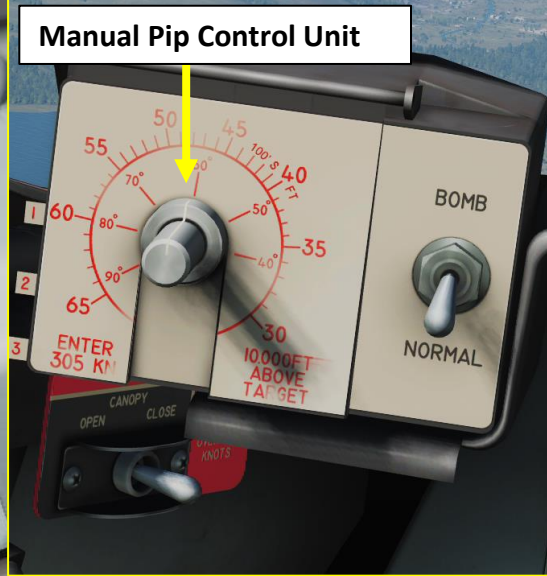

Landing Gear Warning Horn Cutout (Push-to-Silence)

Engine Anti-Ice & Screen Switch

Landing Gear Indicator

Landing & Taxi Lights Switch

Pitot Heat Switch

Fuel Tank Selector Switch

- ALL TANKS OFF = SAFETY (Tanks will not drop, fuel is taken from internal tanks)
- OUTBD ON & JETT = Fuel taken from Outboard external tanks, jettison Outboard Tanks Only
- INBD ON & JETT = Fuel taken from Inboard external tanks, jettison Inboard Tanks Only
- Other positions are self-explanatory

Very important note: this switch must be used to choose where the fuel pumps will take fuel from. If you leave the switch to "ALL TANKS OFF", your fuel pumps will use your internal tanks rather than your external tanks if you have them equipped. Trust me: you will need that extra external tank fuel.

Jettison Fuel Tanks Button
Press this to jettison fuel tanks once the tank(s) you want to drop have been selected by the Fuel Tank Selector Switch.

Outboard External Fuel Tanks Empty Light

Jettison Bombs, Rockets & Fuel Tanks Button
Press to jettison the bombs/rockets/fuel tanks selected

Parking Brake Lever
Pulled = Engaged
Pushed = Disengaged

Canopy Switch
Aft: Open
Fwd: Close

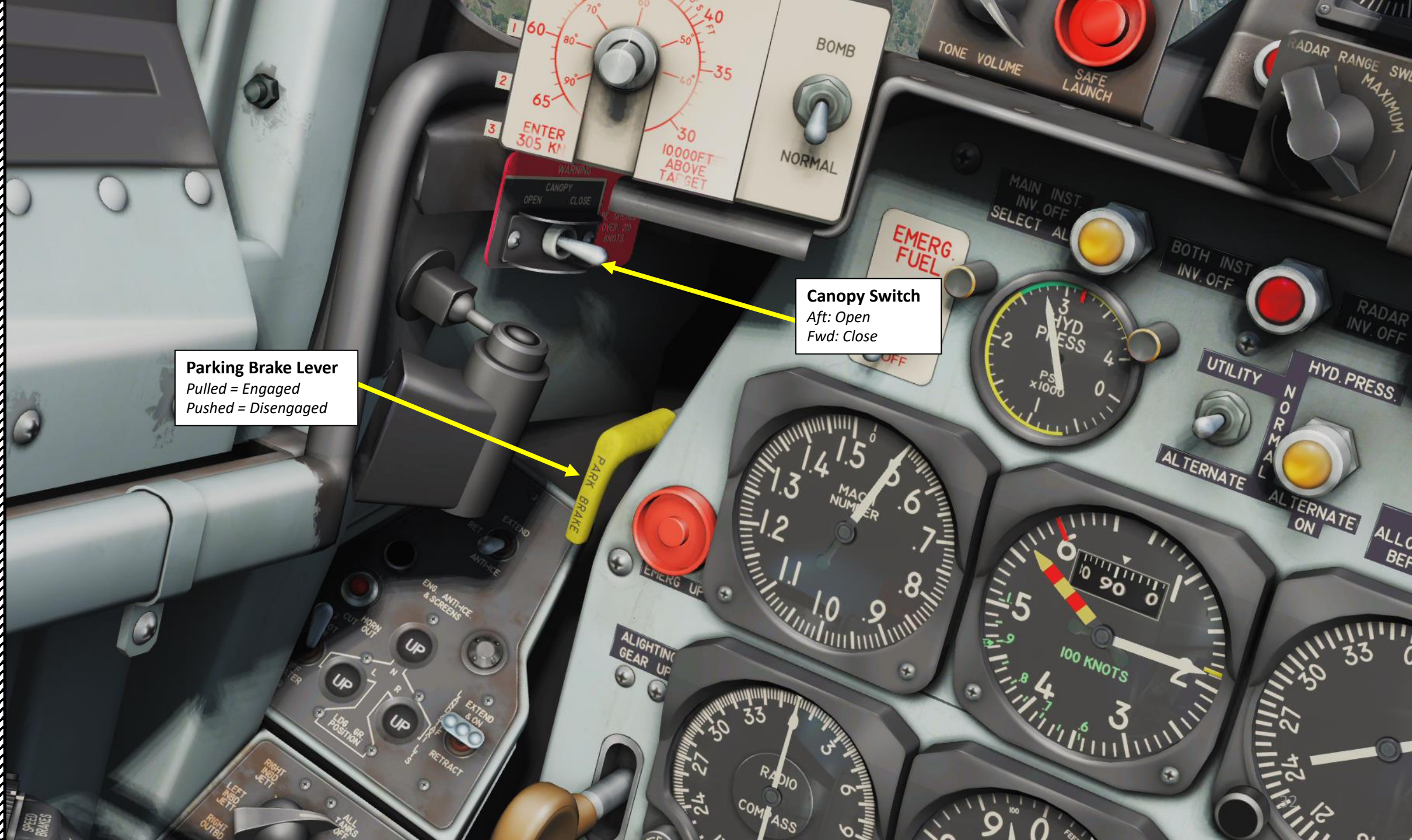

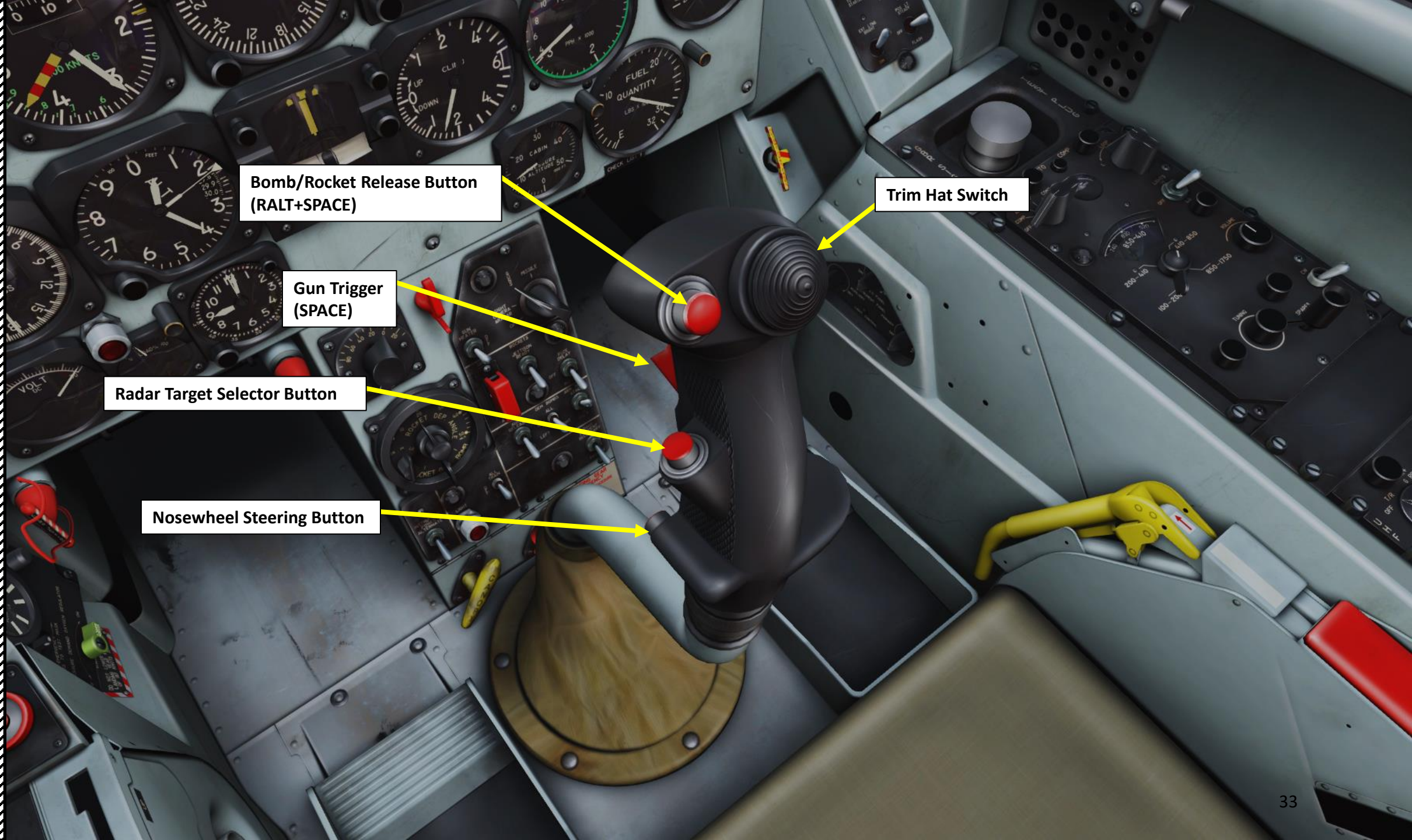

**Bomb/Rocket Release Button
(RALT+SPACE)**

Trim Hat Switch

**Gun Trigger
(SPACE)**

Radar Target Selector Button

Nosewheel Steering Button

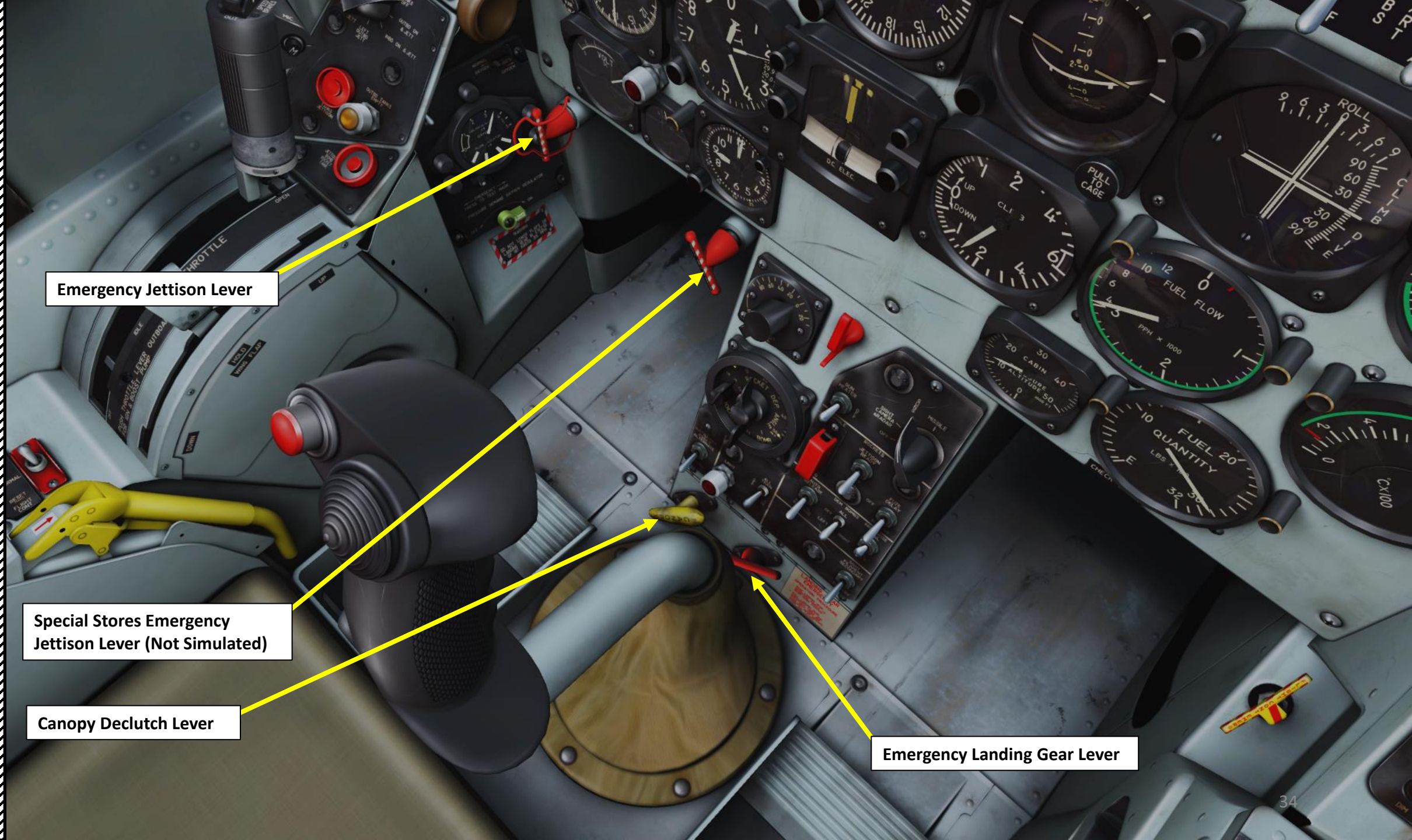

Emergency Jettison Lever

Special Stores Emergency Jettison Lever (Not Simulated)

Canopy Declutch Lever

Emergency Landing Gear Lever

Oxygen Diluter Lever

Oxygen Pressure (PSI) & Flow Indicator

Oxygen Regulator Flow Valve Selector Switch
OPEN = ON/FWD
CLOSED = OFF/AFT

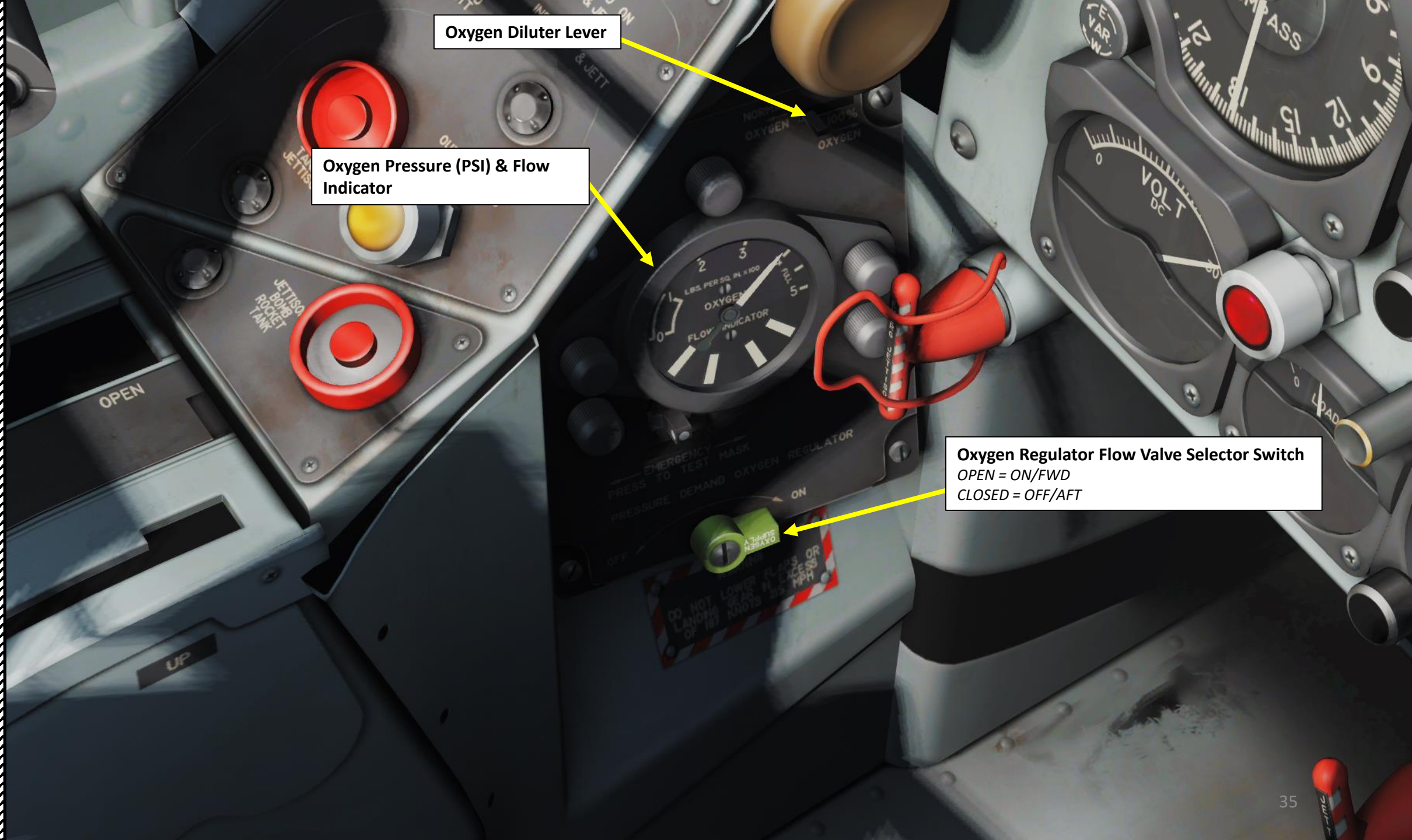

UPPER GUNS MID GUNS LOWER GUNS

OFF

UPPER GUNS MID GUNS LOWER GUNS

ALL GUNS

Gun Mode Selector Switch

Gun Arming Lights

WING FLAP

Flaps Lever
AFT = RETRACTED
MIDDLE = NEUTRAL
FWD = UP

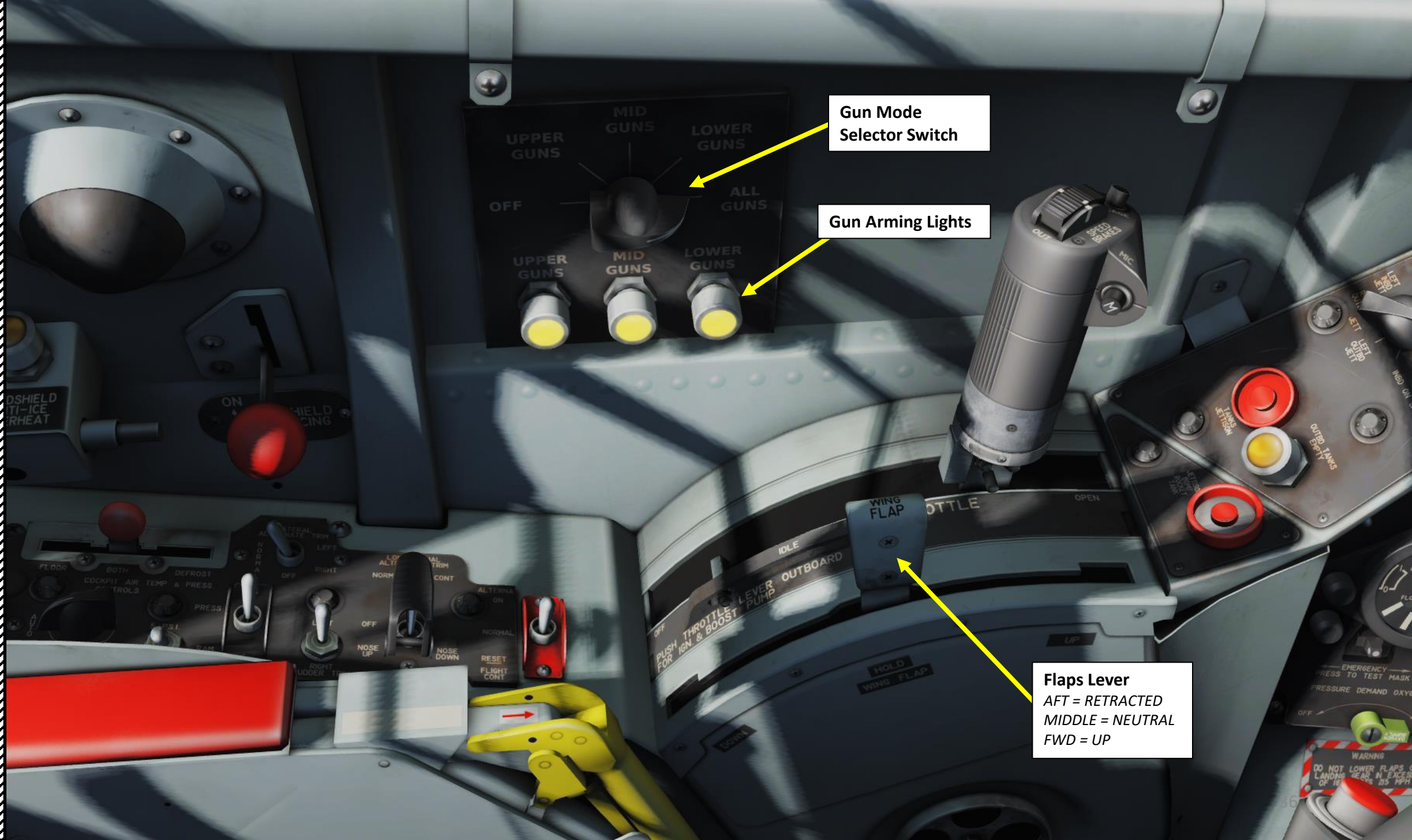

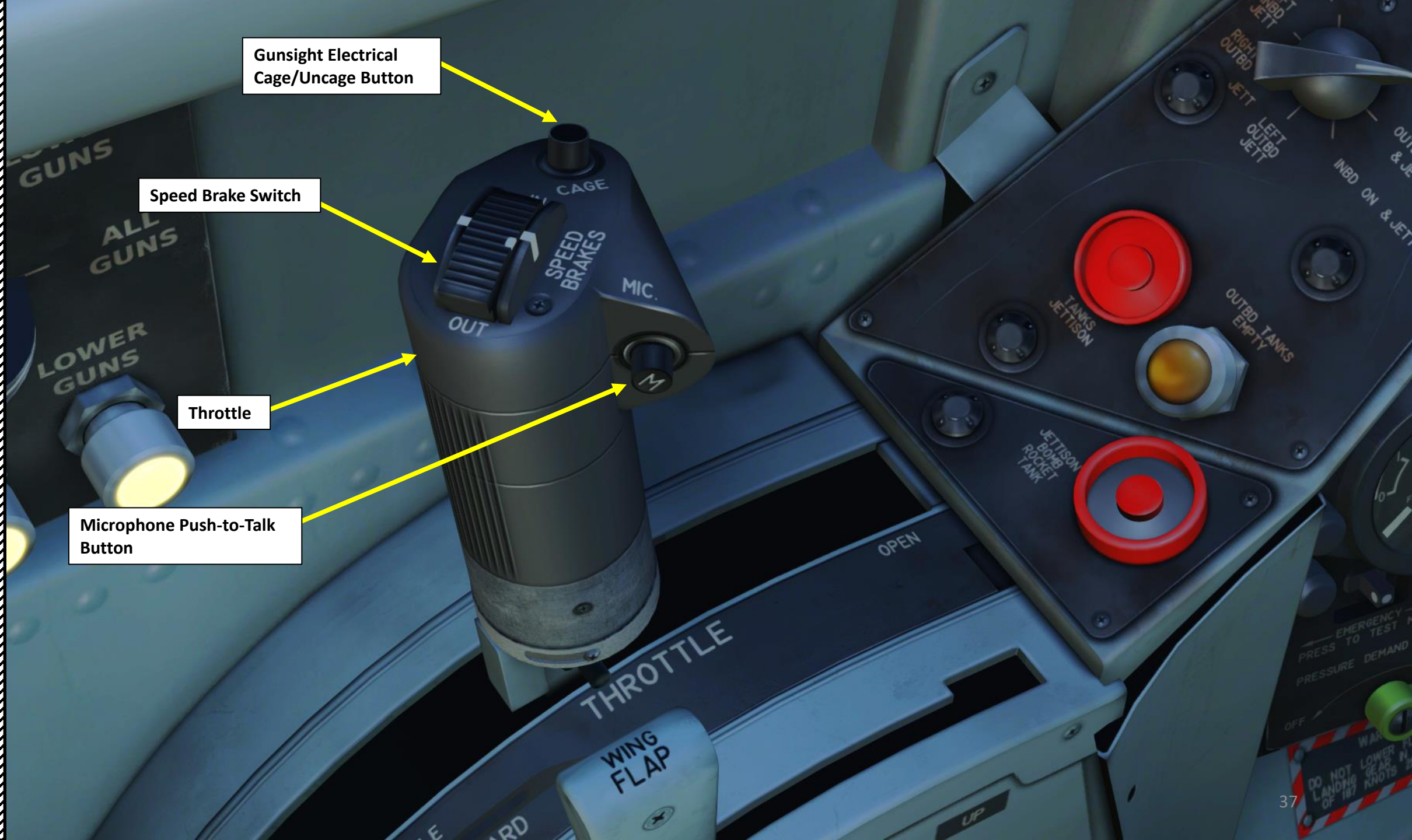

Gunsight Electrical
Cage/Uncage Button

Speed Brake Switch

Throttle

Microphone Push-to-Talk
Button

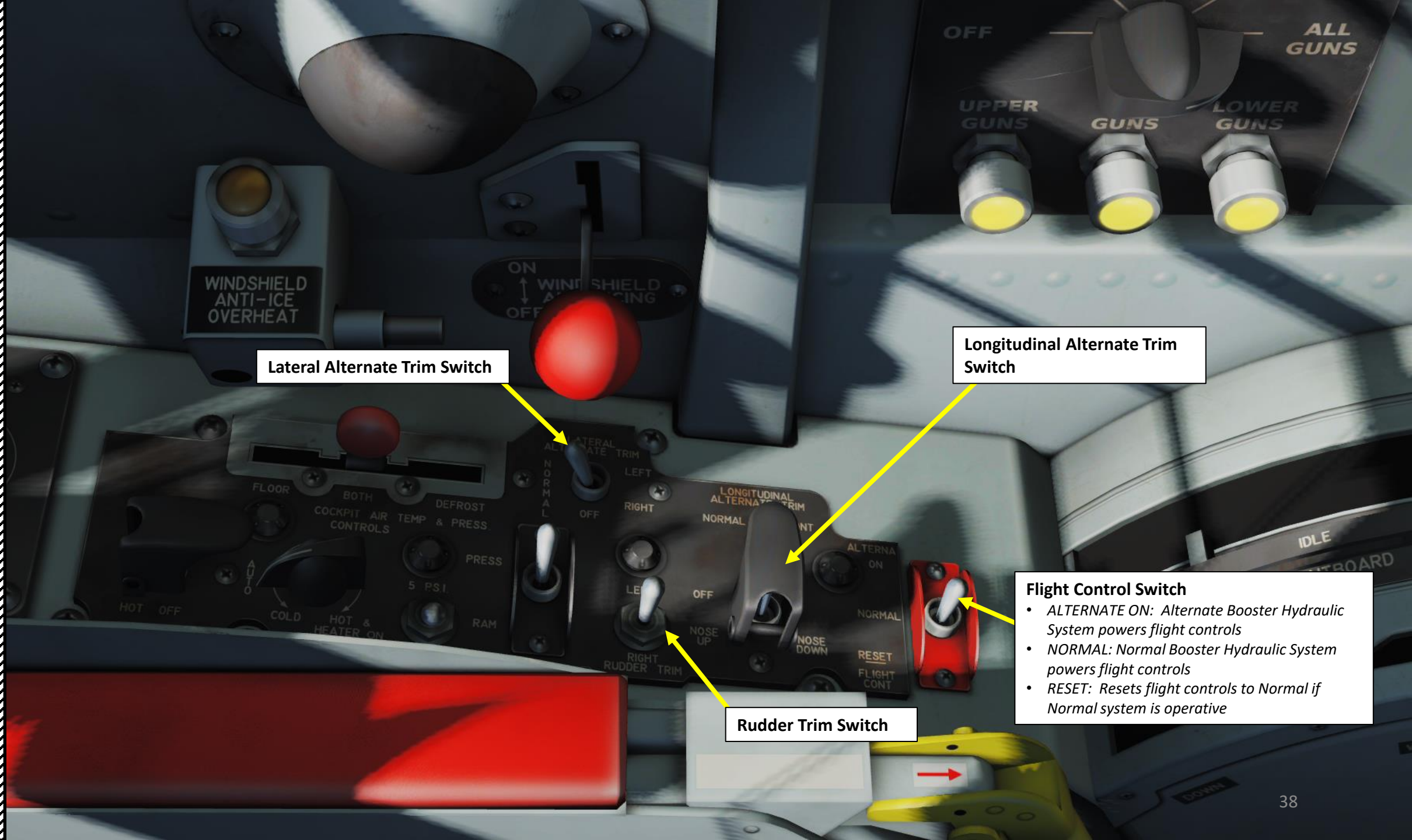

Lateral Alternate Trim Switch

Longitudinal Alternate Trim Switch

Rudder Trim Switch

Flight Control Switch

- *ALTERNATE ON: Alternate Booster Hydraulic System powers flight controls*
- *NORMAL: Normal Booster Hydraulic System powers flight controls*
- *RESET: Resets flight controls to Normal if Normal system is operative*

Rocket Intervalometer

Windshield Anti-Ice
Overheat Light

Air Outlet Selector

Windshield Anti-Ice Lever
UP = ON / DOWN = OFF

Cockpit Pressure Control
Switch

Cockpit Air Temperature Control
Switch

Cockpit Air Temperature Control
Rheostat

Cockpit Pressure Schedule
Selector Switch

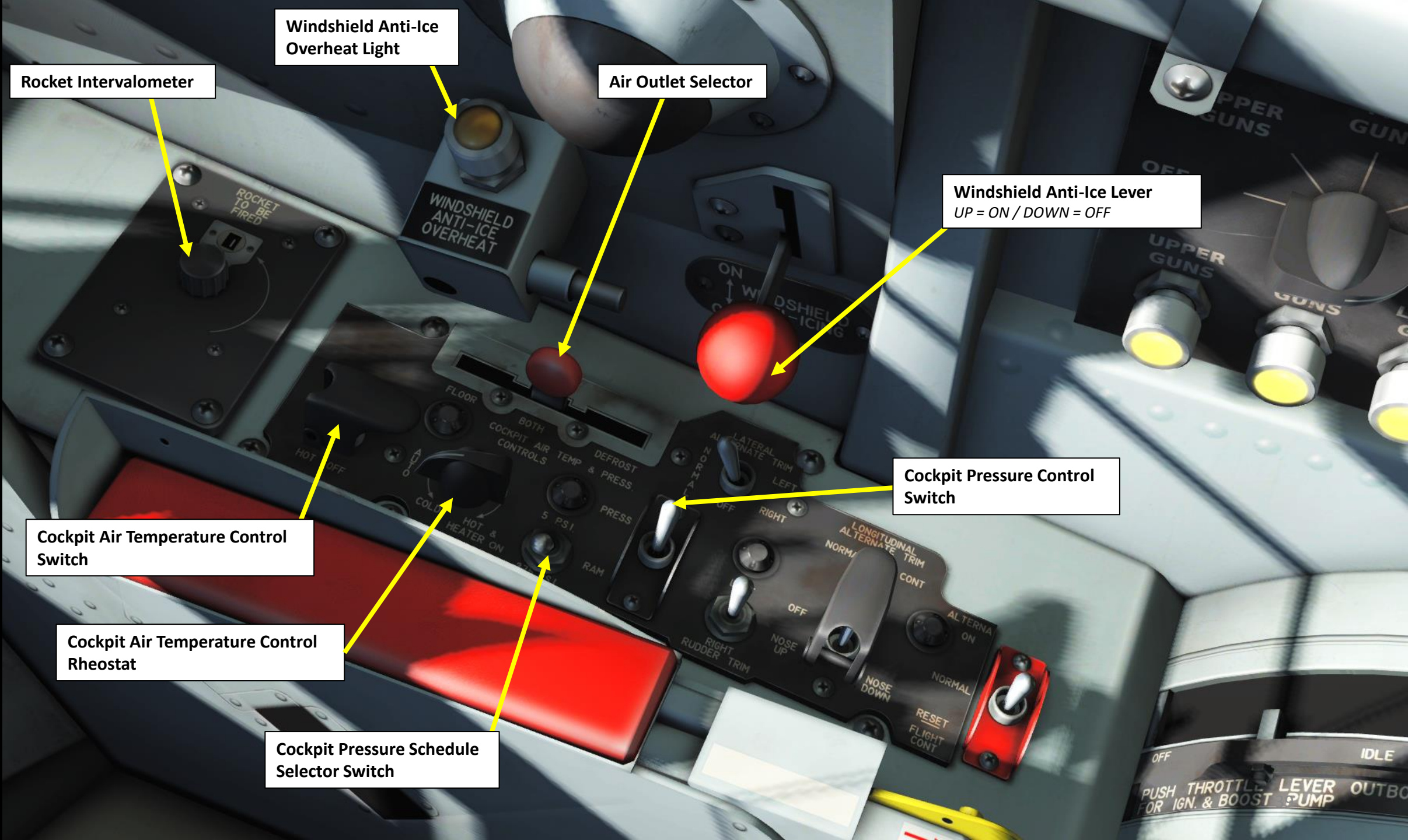

Circuit Breaker Panel

C-4A Cockpit Utility Light



Maximum Operating Speed Limit (VMO) (kts)
(Red Index, do not use as a reference)

Maximum Gear/Flap Extension Speed
(Yellow Index)

Mach Scale

Indicated Airspeed (kts)

Indicated Airspeed Limit (KTS) – Do not Exceed
(This is what you use as a reference)

Altitude (x 100 ft)

Altitude (x 1000 ft)

Altitude (x 10000 ft)

The altimeter reads as follows:
Long Thin Needle: @ 2 = 20000 ft
Short Thick Needle @ 1 = 1000 ft
Long Thick Needle @ approx 1 = 100 ft

TOTAL ALTITUDE = 20000 + 1000 + 100 ft
= 21100 ft

QFE Altimeter Setting (inches Hg)

Barometric Pressure Setting Knob

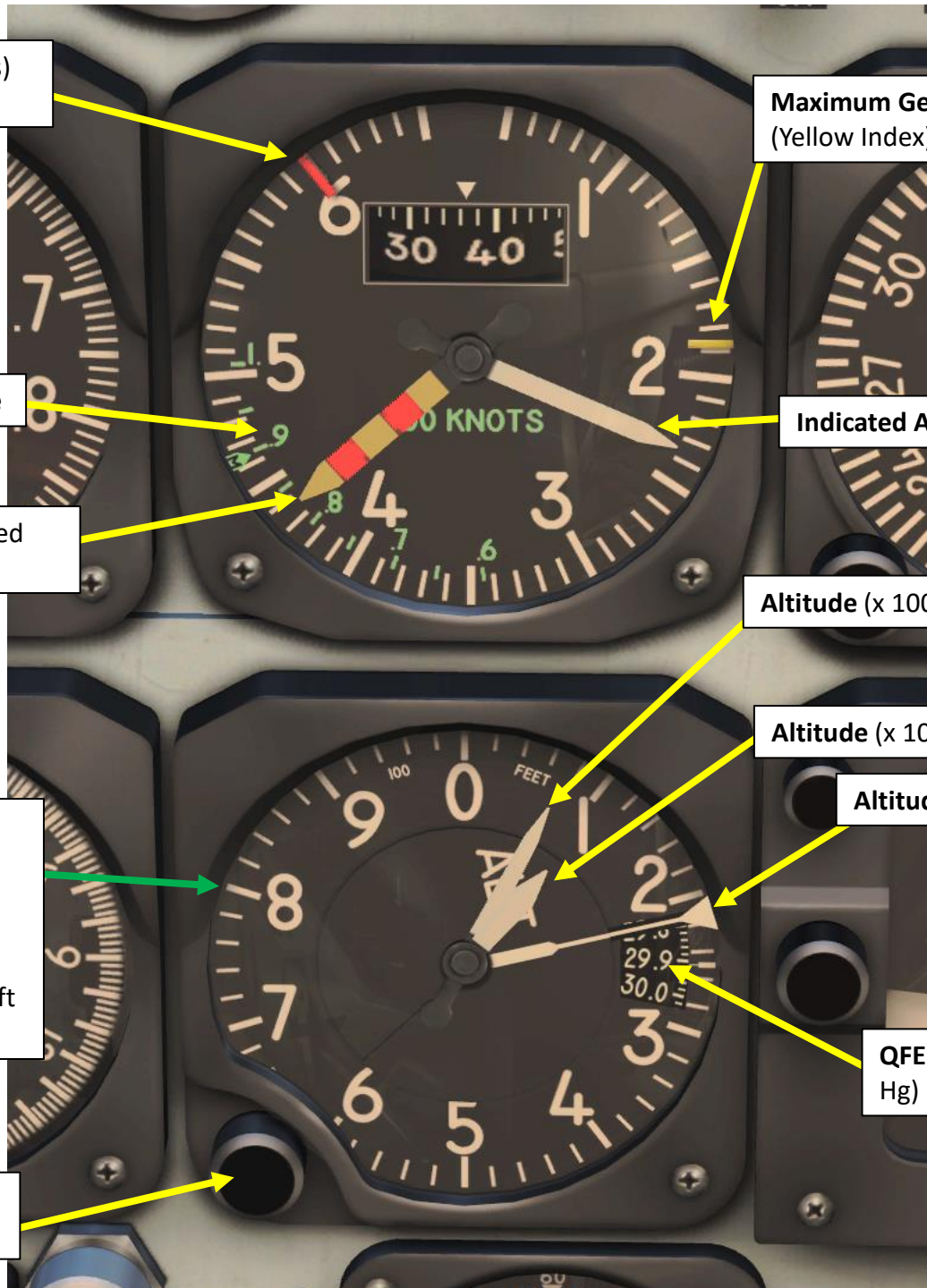



Flashlight
• ON/OFF: LALT + L



Speedbrakes
(Hydraulically actuated)

Flaps
(Electrically actuated)



The flaps are controlled with the wing flap lever. It is important to note that the lever has three positions: Up, Neutral (Hold) and Down. To deploy flaps, you need to set the lever to DOWN, wait a few seconds, then set the lever back to Neutral (HOLD). This will prevent the electrical motor from constantly running once the flap is set in the desired position.

Keep in mind that there are no flap position indicator in the cockpit and deploying the flaps at an airspeed greater than the Max Gear/Flap Extension Speed can jam them (this speed is visible on the airspeed indicator's yellow index). Always make sure that you are below 185 kts before deploying your flaps or landing gear.



Maximum Gear/Flap Extension Speed
(Yellow Index)





Position & Fuselage Lights Selector Switch
• STEADY / OFF / FLASH

Exterior Lights Dimmer Switch

Position Light (Red)

Position Light (Green)

Position Lights (White & Orange)

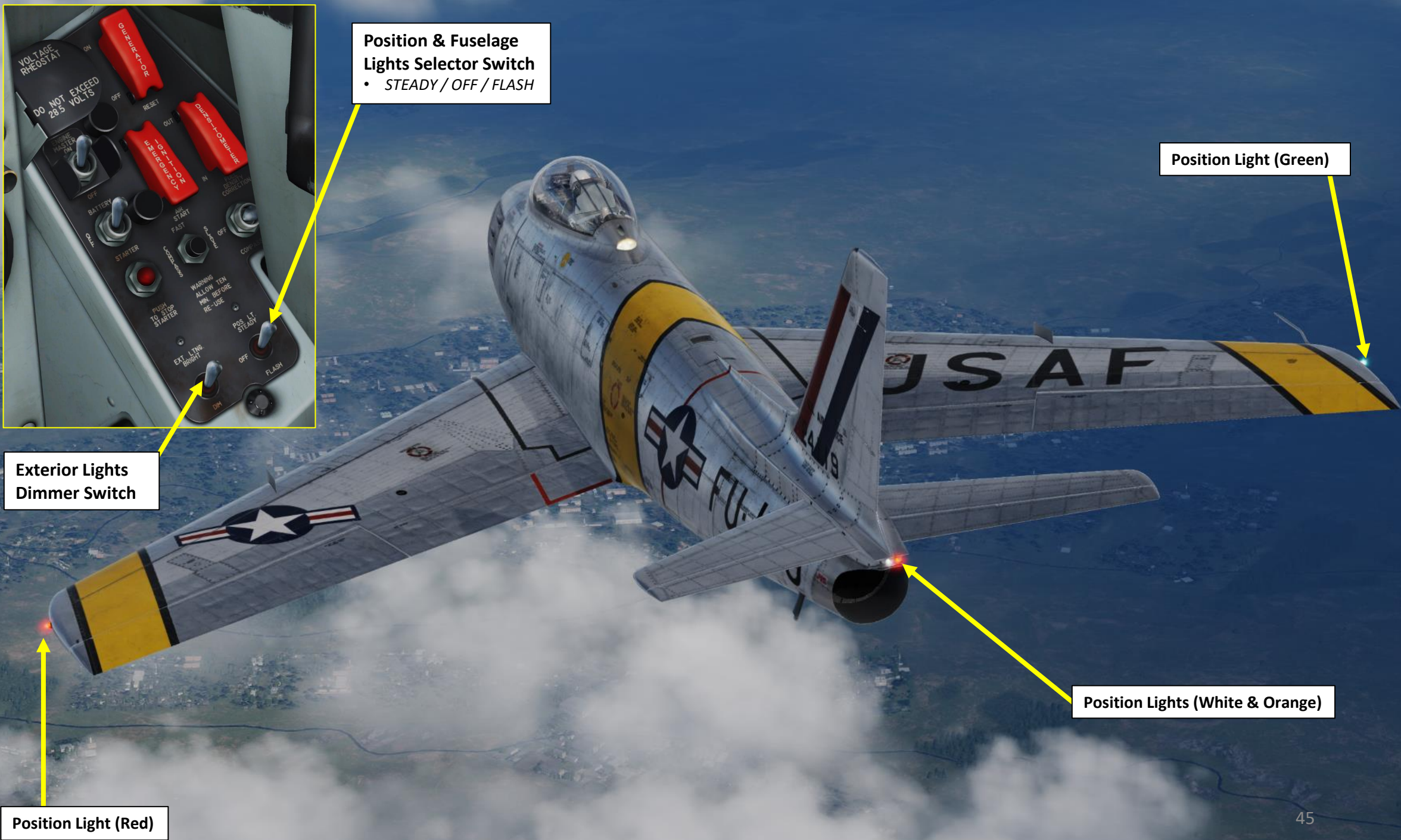



Position & Fuselage Lights Selector Switch
• STEADY / OFF / FLASH

Exterior Lights Dimmer Switch

Fuselage Light (White)

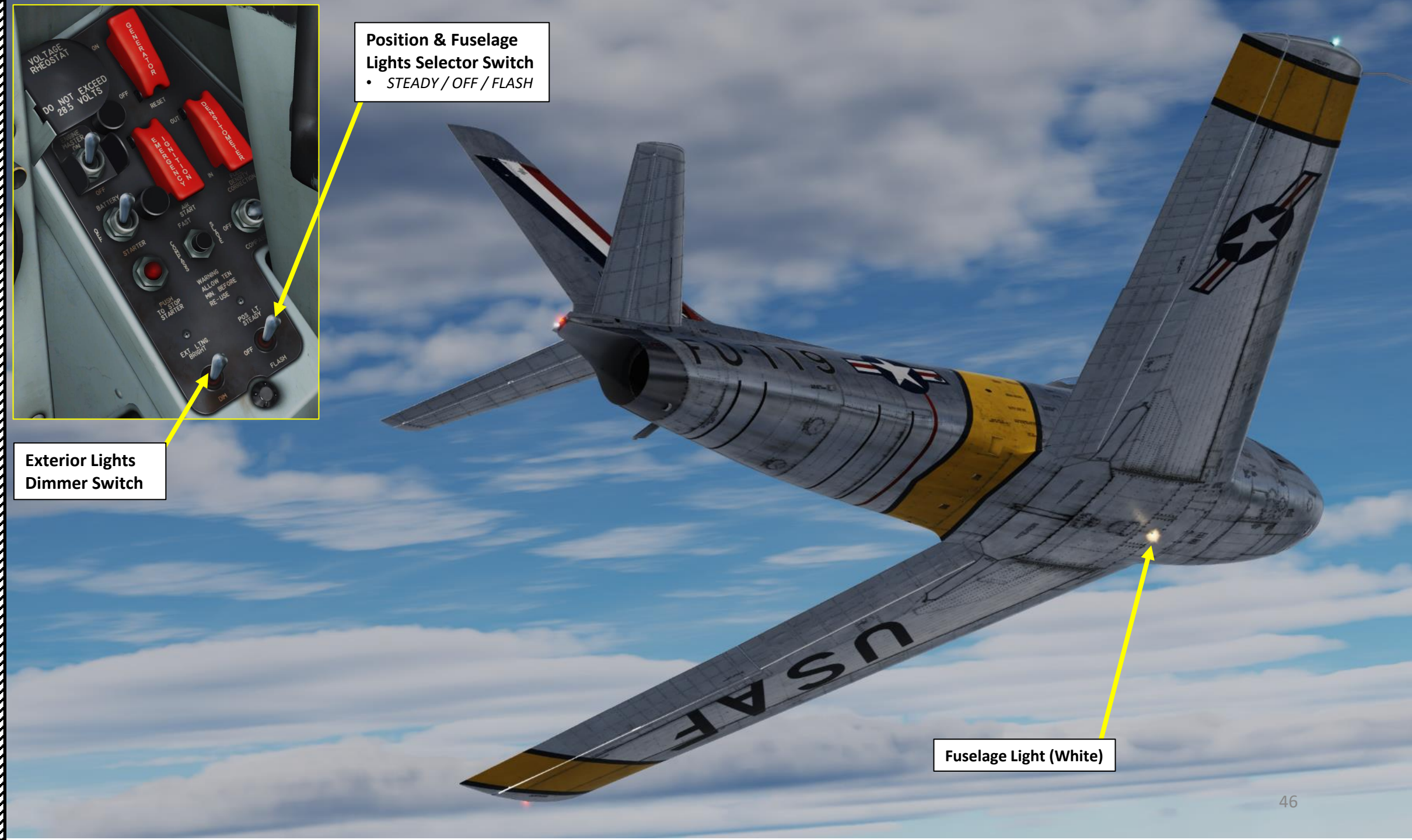



Landing Light

Taxi Light



Landing & Taxi Lights Switch
• EXTEND & ON / OFF / RETRACT

Dive Angle Reference Lines (deg)

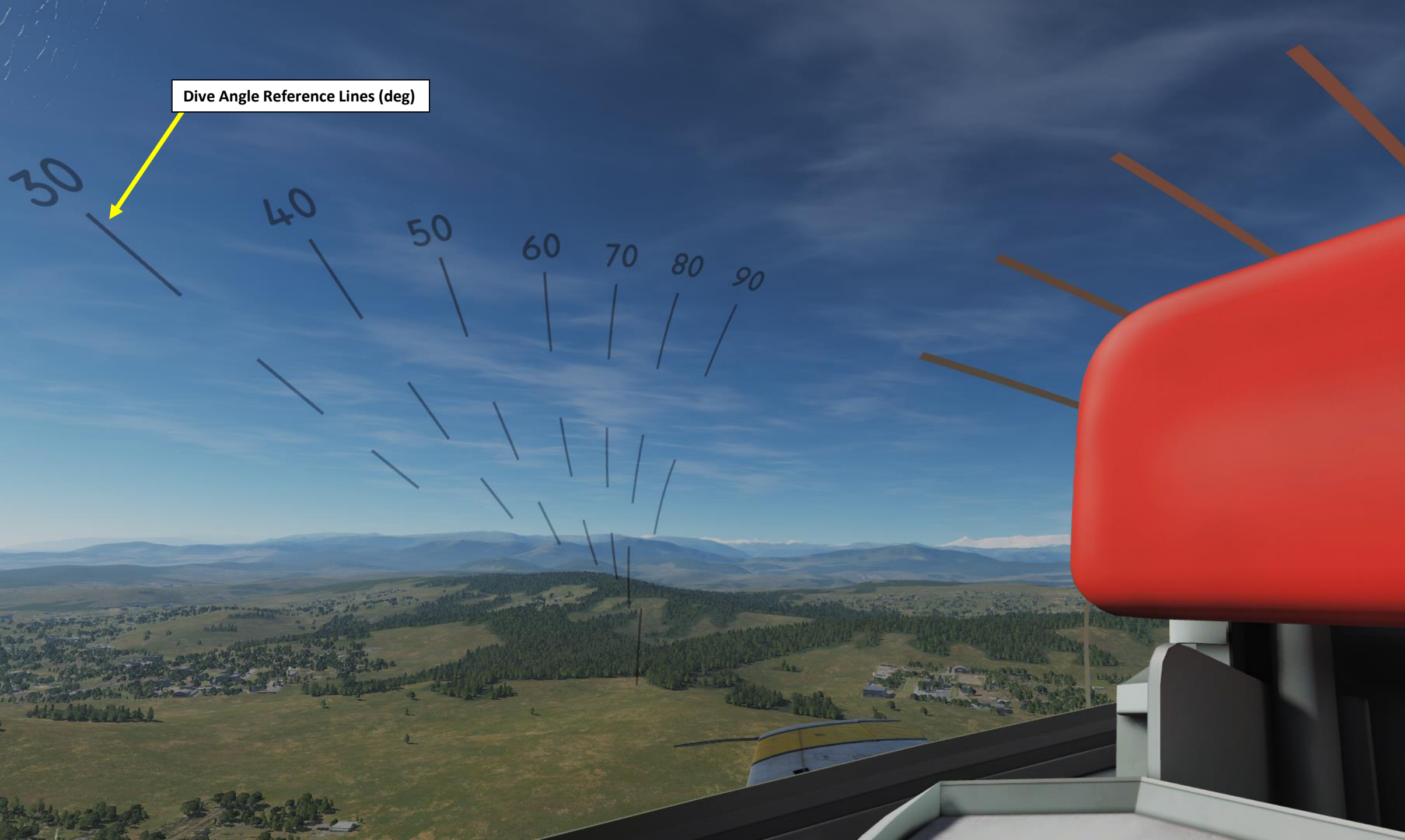

F-86F
SABRE

PART 3 - COCKPIT





Wing "Fin"
The fin on the upper surface that prevented airflow from spreading over the wing area.

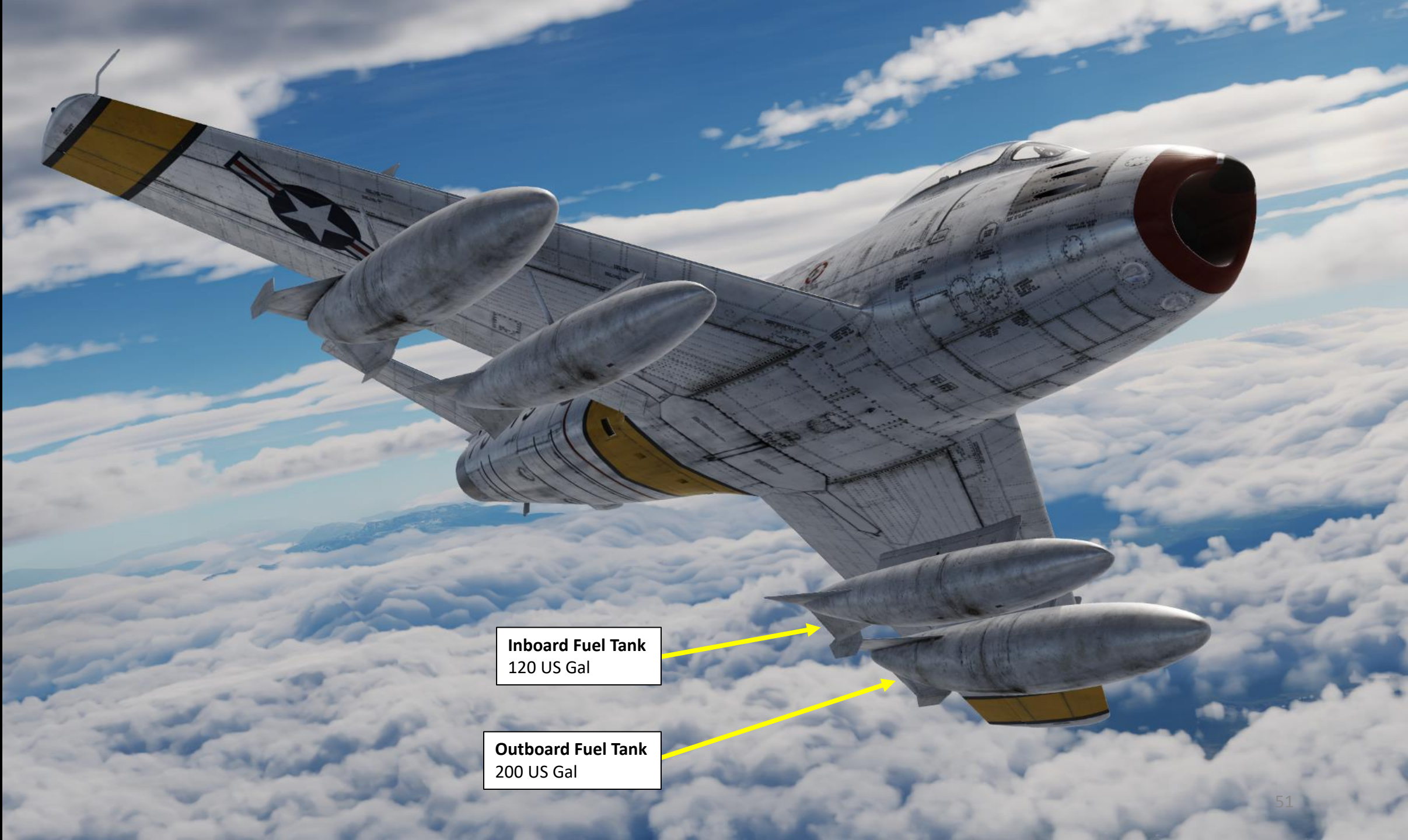

Inboard Fuel Tank
120 US Gal

Outboard Fuel Tank
200 US Gal

• **SPECIFICATIONS**

FUEL —JP-4 (MIL-J-5624)
ALTERNATE **

OIL —MIL-O-6081, GRADE 1010
ALTERNATE-MIL-O-6081, GRADE 1005
BELOW —29°C, USE GRADE 1005.

**HYDRAULIC
FLUID** —MIL-H-5606

ALCOHOL —MIL-A-6091

OXYGEN —BB-O-925

**servicing
diagram**



1. Battery
2. External AC Power Receptacle*
3. Nose Gear Emergency Lowering System Accumulator
4. Flight Control Normal Hydraulic System Accumulator
5. Fuel Filter Deicing System Alcohol Tank
6. External DC Power Receptacles
7. Aft Fuselage Fuel Tank Filler
8. Flight Control Alternate Hydraulic System Fluid Level Indicator Access Door
9. Left Wing Fuel Tank Filler
10. Left Drop tank Filler
11. Oxygen Filler Valve
12. Forward Fuselage Fuel Tank Upper Cell Filler (Filled first to utilize full tank capacity)
13. Utility Hydraulic System Reservoir
14. Right Wing Fuel Tank Filler
15. Right Drop Tank Filler
16. Engine Oil Tank
17. Forward Fuselage Fuel Tank Lower Cell
18. Flight Control Alternate Hydraulic System Accumulator (Accumulators*)
19. Flight Control Normal Hydraulic System Fluid Level Indicator Access Door

START-UP



START-UP

* You may rely on your crew chief to check these items if you desire. However, if preflight inspection or servicing was performed at a base where ground personnel are not completely familiar with your airplane, you should check these items yourself.

† Some airplanes (refer to applicable text).

‡ F-86F-1 through F-86F-20 Airplanes, F-86F-25 Airplanes AF51-13170 through -13510 and AF52-5272 through -5386, and F-86F-30 Airplanes AF52-4305 through -5063.

1 NOSE

- Nose gear ground safety lock—Removed.
- Tow pin safety cap—Tight.
- Intake duct—Clear.
- Gun port plugs—As required.
- Landing and taxi lights—Retracted.
- Nose gear accumulator gage (in nose wheel well) pressure—1200-1250 psi.
- Emergency nose gear extension control valve—Reset. (pushed full back).*

2 FORWARD FUSELAGE AND RIGHT WING LEADING EDGE

- Slats †—Check.
- External stores—Check installation.
- Pitot head—Uncovered; static ports clean. 
- Position light and wing tip—Check.

3 RIGHT WING TRAILING EDGE AND AFT FUSELAGE

- Aileron and flap—Check.
- Drop tanks—Check fuel and caps secure.
- Main gear—Check.
- Right landing gear wheel well—Check.
- Speed brake—Check.
- Flight control alternate accumulator or accumulators‡ gage (in speed brake well) pressure—600-650 psi.
- Flight control normal compensator shaft—Check 1/4 to 1-1/4-inch extension.

4 EMPENNAGE

- Tail-pipe cover—Removed.
- Tail cone and position lights—Check.

5 AFT FUSELAGE AND LEFT WING TRAILING EDGE

- Flight control alternate compensator shaft—Check 1/4 to 1-1/4-inch extension.
- Speed brake—Check.
- Flight control alternate pump circuit breaker (within access door just forward of speed brake)—IN.
- Left landing gear wheel well—Check.
- Flight control normal accumulator gage (in left wheel well) pressure—600-650 psi:
- Landing gear door switch—CLOSE.
- Drop tanks—Check fuel and caps secure.
- Flap and aileron—Check.

6 LEFT WING LEADING EDGE AND FORWARD FUSELAGE

- Position light and wing tip—Check.
- External stores—Check installation.
- Slats †—Check.

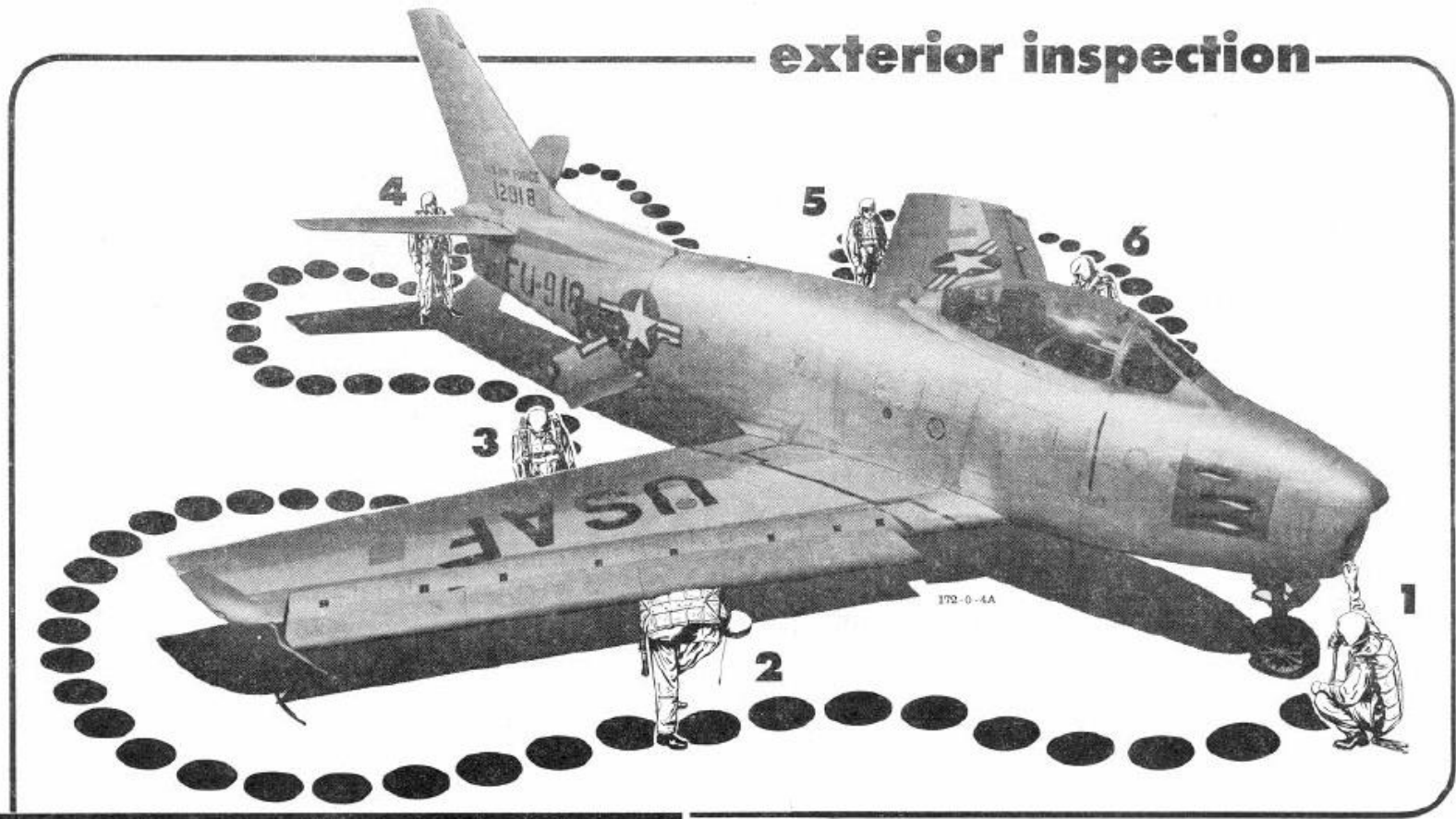

exterior inspection

Check surfaces for cracks, distortions, loose rivets, and indications of damage; check for signs of hydraulic fluid, fuel, and oil leaks; check tires for general condition, and proper inflation; check all access doors and panels secured; check position of gear doors, gear strut extension, and condition of wheels.

NOTE: There are no slats on the F-86F-35 

START-UP

Note: You do not need to try to use the parking brake since it is hydraulically-driven. The "Normal System" hydraulic pumps are engine-driven and require engine power to function.

1. Select ground crew by pressing "\" and F8.
2. Select "GROUND ELECTRIC POWER" by pressing F2
3. Select "ON" by pressing F1 to turn on ground power
4. Ensure Flight Control Switch is set to "ALTERNATE ON", then confirm that the ALTERNATE ON light is illuminated. Set Hydraulic System Indication Selector to ALTERNATE (Down) position and confirm that there is a positive hydraulic pressure.

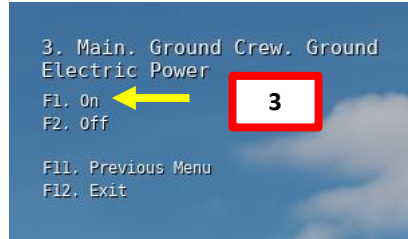
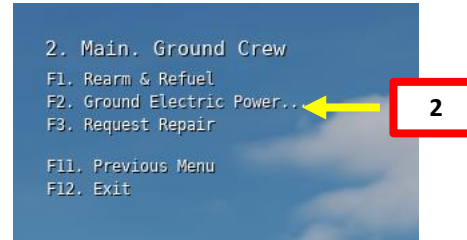
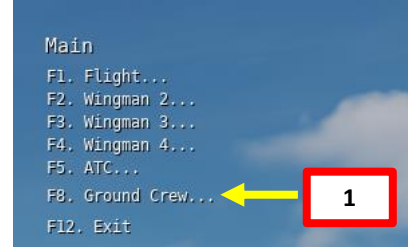

4a Flight Control Switch



START-UP

5. Ensure throttle is set to OFF by pressing "END" key (by default)
6. Set Engine Master Switch to ON (UP)
7. Set Battery Switch to STARTER (Left Click, Down Position) for 2 to 3 seconds, then set it to BATTERY (Right Click, Up Position)
8. Wait for engine RPM to reach 3 %
9. If engine does not reach 3 % within 1 minute, press the Stop-Starter Button, set Engine Master Switch to OFF and Battery Switch to OFF. Then, repeat steps 5 to 8.
10. Once engine RPM reaches 3 %, set throttle to OUTBOARD by pressing "ALT+HOME" key binding (by default)
11. Once engine RPM reaches 6 %, set throttle to IDLE by pressing the "ALT+HOME" key binding (by default) a second time.

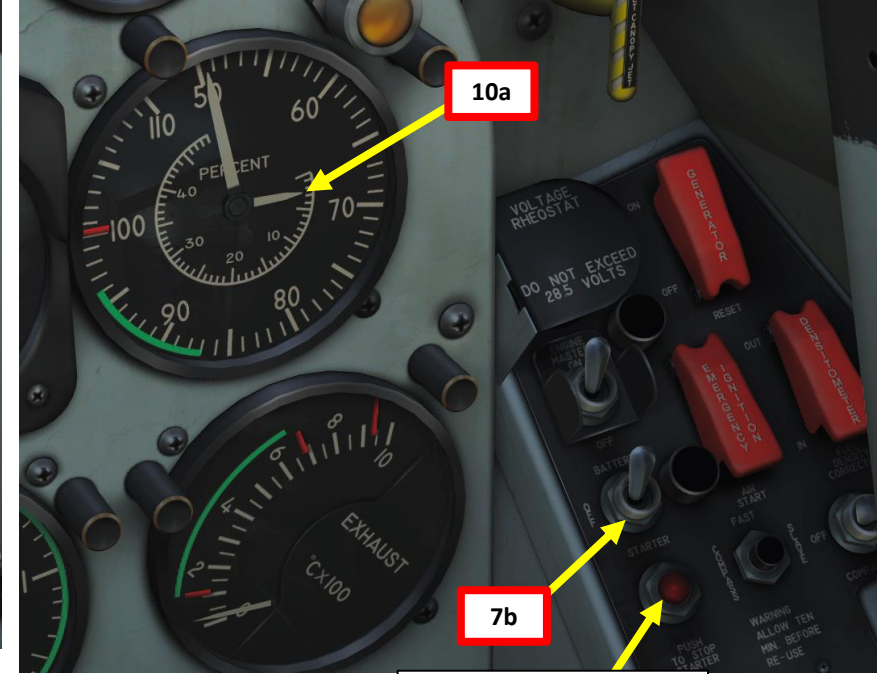
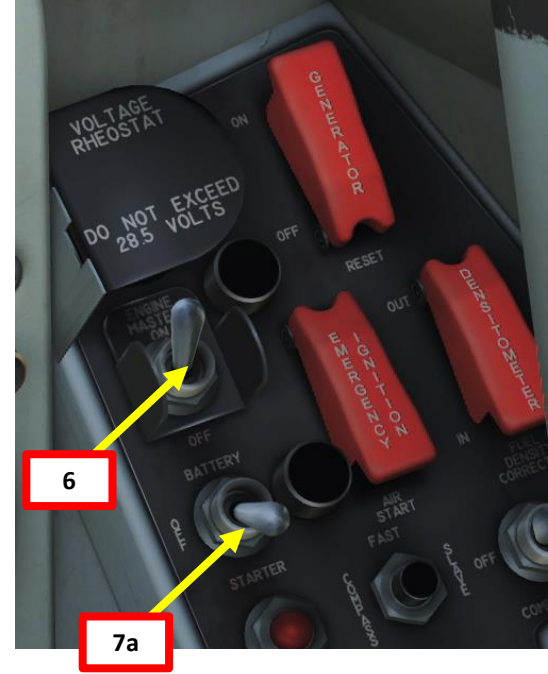

Stop-Starter Button

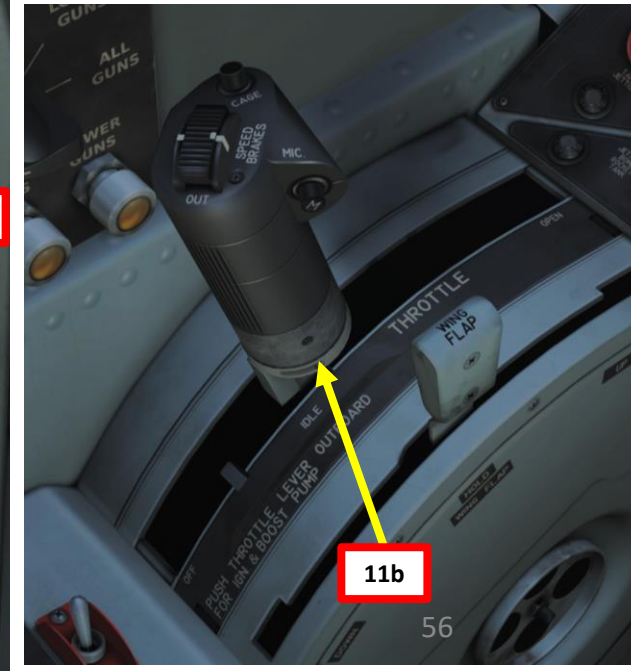
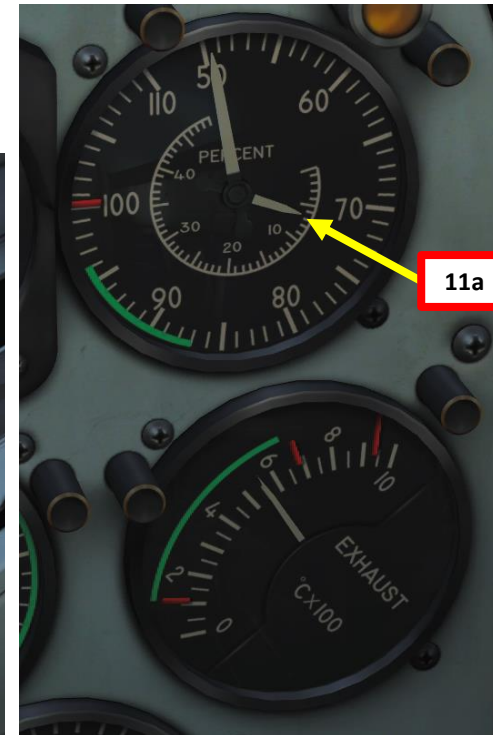
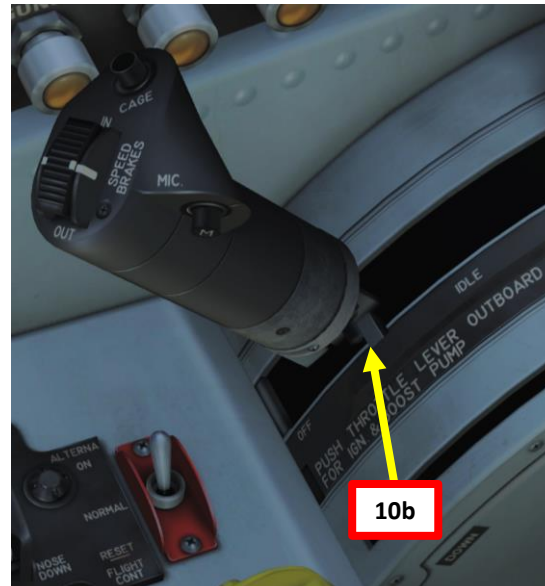

START-UP

12. The Main (Normal) Hydraulic System pumps are engine-driven and will only kick in around 25 % RPM.
13. Once you have sufficient engine RPM (25+ %), set the Flight Control Switch to RESET for 2-3 seconds, then set it to "NORMAL". Once the Main (Normal) Hydraulic system pumps is selected, the "ALTERNATE ON" warning light should extinguish.
14. Set Hydraulic System Indication Selector to NORMAL (Middle) and confirm positive hydraulic pressure.
15. Retract airbrakes

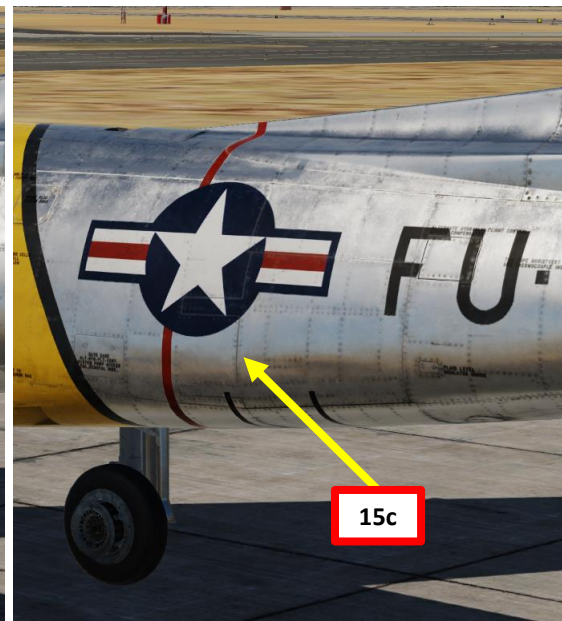
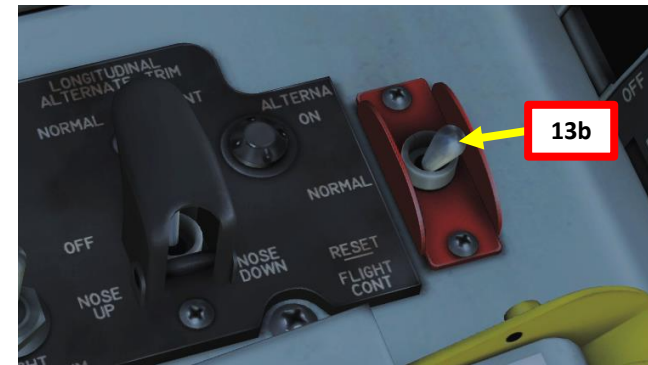

START-UP

16. Set Parking Brake by:
- Pulling and holding the parking brake lever
 - Pressing the wheel brake pedals while holding the parking brake lever
 - Releasing the wheel brakes.
 - You can then let go of the parking brake lever; it will remain in the ENGAGED position (pulled).

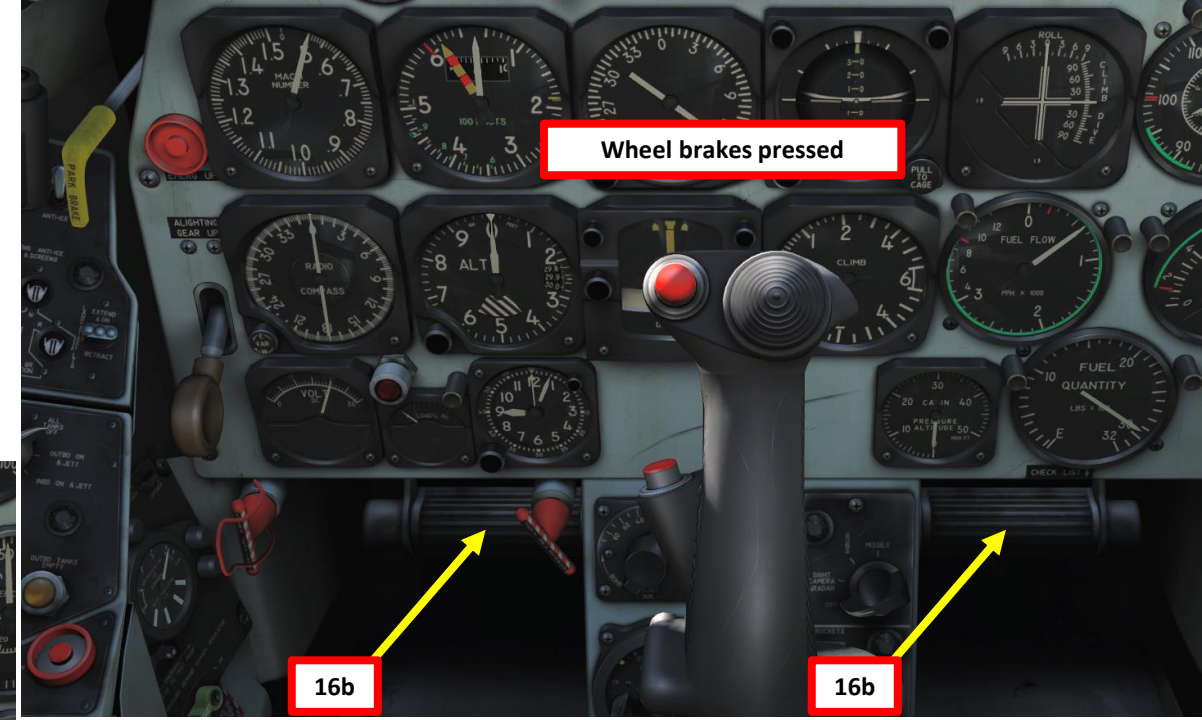

START-UP

17. Set Radio Power Selector to T/R (Transmit-Receive).
18. Set IFF (Identify-Friend-or-Foe) Master Selector to NORM (Normal). If specified in the mission briefing, set mode as required.



START-UP

19. Set your flaps Fully Down, and then set them to the Neutral position.
20. Set takeoff trim by setting your trim manually until you see the “TAKE-OFF POS.IND. LATERAL–DIRECT LONGIT.” light blink briefly. This light means that you are trimmed for takeoff.
21. Set your Oxygen Flow Valve selector to ON
22. Disconnect Ground Power
 - a) Select ground crew by pressing “\” and F8.
 - b) Select “GROUND ELECTRIC POWER” by pressing F2
 - c) Select “OFF” by pressing F2 to disconnect ground power

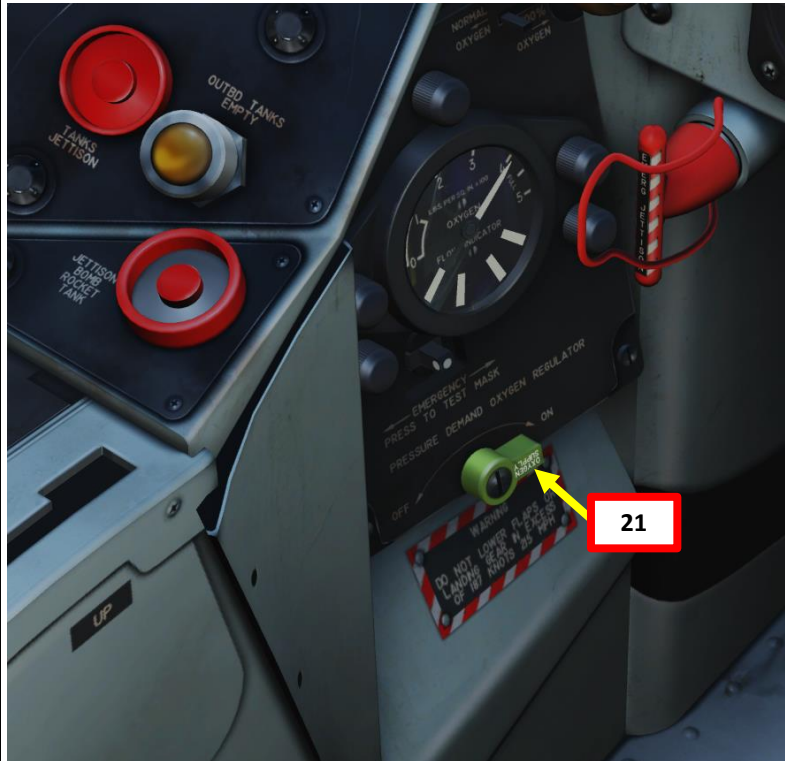
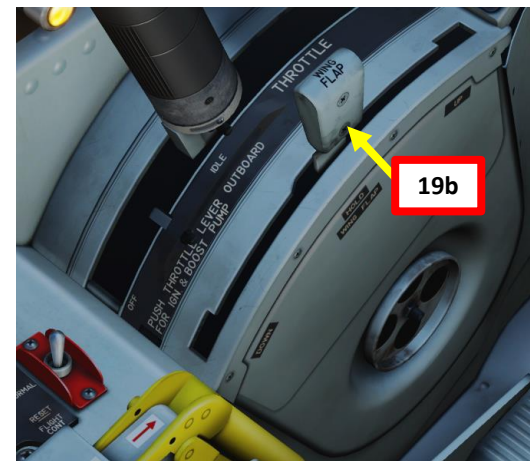
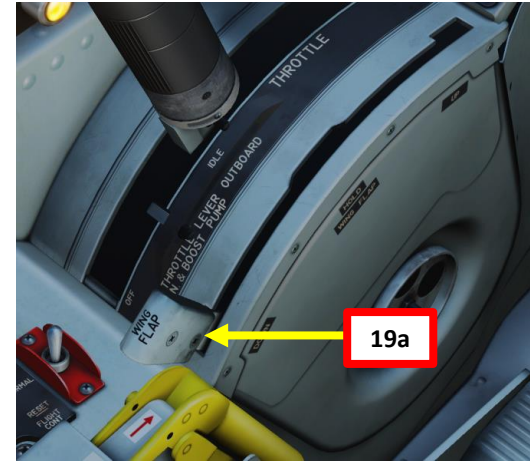

Main

F1. Flight...

F2. Wingman 2...

F3. Wingman 3...

F4. Wingman 4...

F5. ATC...

F8. Ground Crew... ← 22a

F12. Exit

2. Main. Ground Crew

F1. Rearm & Refuel

F2. Ground Electric Power... ← 22b

F3. Request Repair

F11. Previous Menu

F12. Exit

3. Main. Ground Crew. Ground
Electric Power

F1. On ← 22c

F2. Off

F11. Previous Menu

F12. Exit

START-UP

- 23. Close your canopy with the Canopy Switch FWD (CLOSE).
- 24. Once ready to taxi, release parking brake by tapping your wheel brakes.

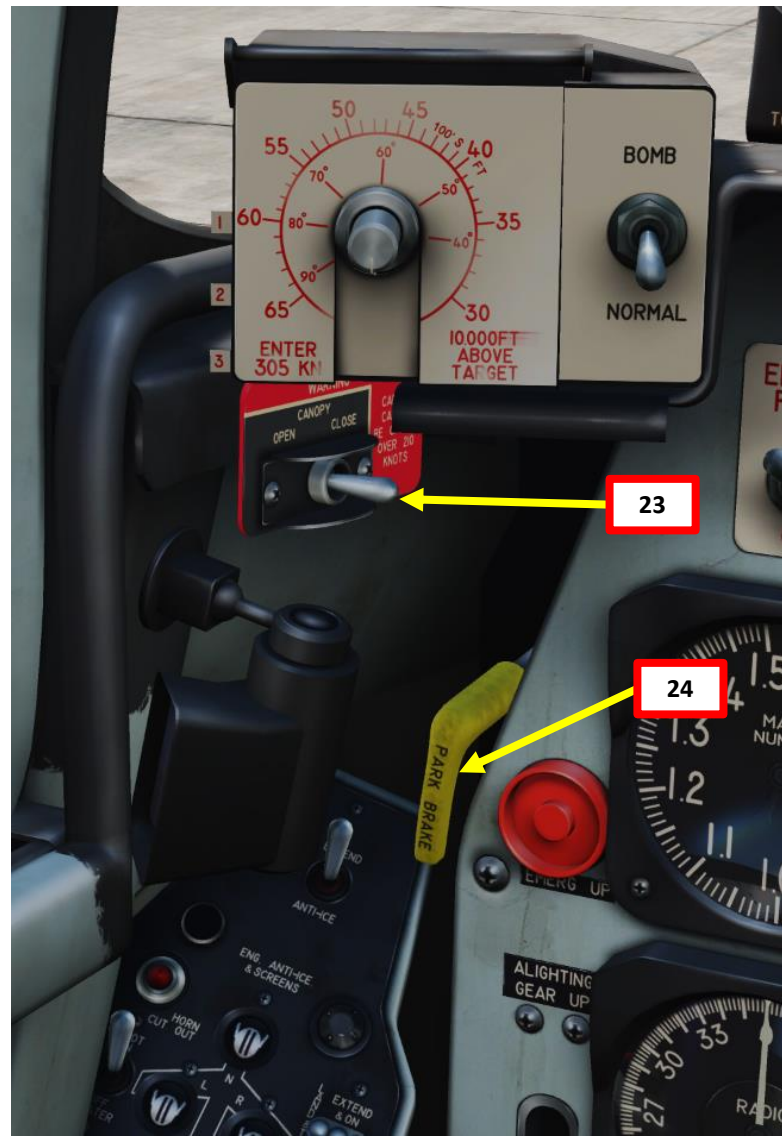





F-86F
SABRE

TAKEOFF



PART 5 - TAKEOFF

TAKEOFF

1. Increase the engine speed to approximately 60% rpm to start moving. Then, return the throttle to the IDLE position to allow the aircraft to move under its own momentum.
2. Line up on the runway using your nosewheel steering button on the stick during turns ("S" binding by default) and your rudder pedals. Toe brakes can be used as well.
 - Note: The nose wheel steering system will not engage if the nose wheel is more than 21° to either side of center. Should the nose wheel be turned more than this, it must be brought into the steering range by use of the wheel brakes. When the nose wheel steering activation button on the control stick is released, the nosewheel steering system starts to work as a shimmy damper and the nose wheel goes to the self-castering mode.
3. Check for your flaps (DOWN/DEPLOYED) and your airbrakes (RETRACTED). Ask your wingmen if you have bad visibility.
4. Check elevator takeoff trim setting by trimming manually until you see the "TAKE-OFF POS.IND. LATERAL-DIRECT LONGIT." light blink briefly. This light means that you are trimmed for takeoff.

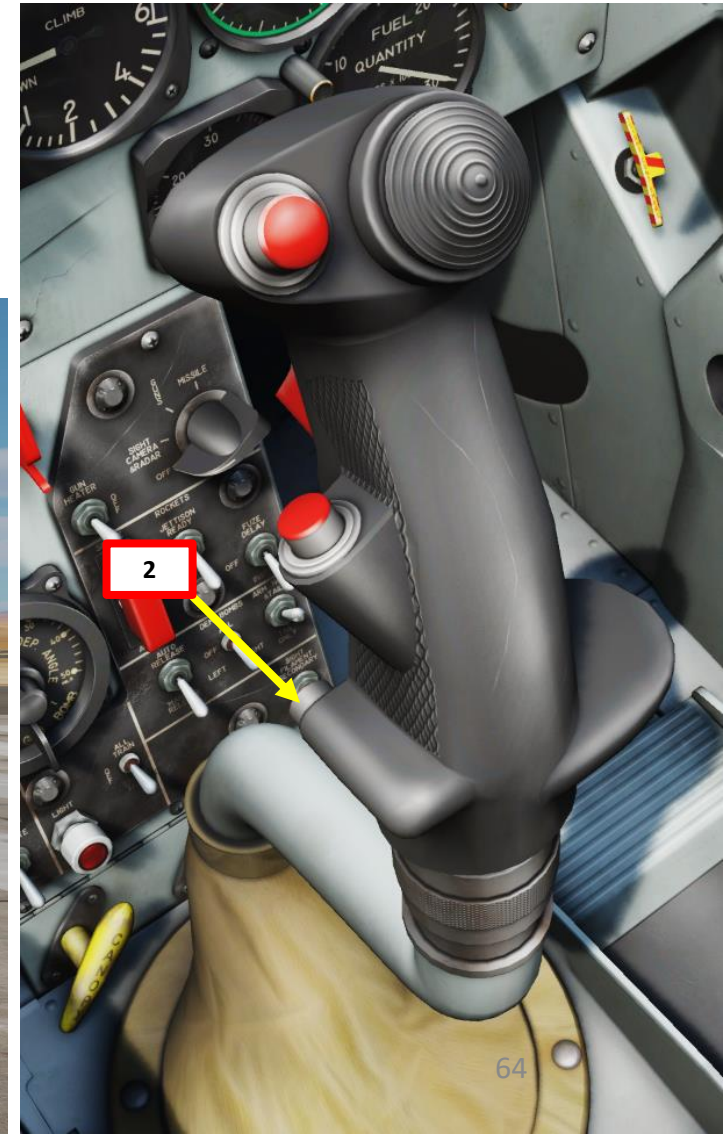

TAKEOFF

5. Set your wheel brakes ON with the toe brakes
6. Slowly increase throttle to Max Power. Keep in mind that the throttle is slow to respond to input.
7. Release brakes at full power
8. Use rudder to make small adjustments, but do not use the nosewheel steering. When reaching 95 to 100 kts, pull the stick fully aft to lift the nosewheel off the ground. Aircraft liftoff should be expected between 110 to 115 kts.
9. At 120 to 125 kts, rotate and hold airspeed below 125 kts to avoid overspeeding when retracting the landing gear and flaps.

Liftoff & Takeoff Speeds

<u>Takeoff Weight (lbs)</u>	<u>Indicated speed of nosewheel liftoff (kts)</u>	<u>Takeoff indicated speed (kts)</u>
15000	100	115
18000	110	135
20000	120	140



TAKEOFF

- 10. As soon as you have a positive rate of climb, retract landing gear. Landing gear should be fully retracted below 155 kts.

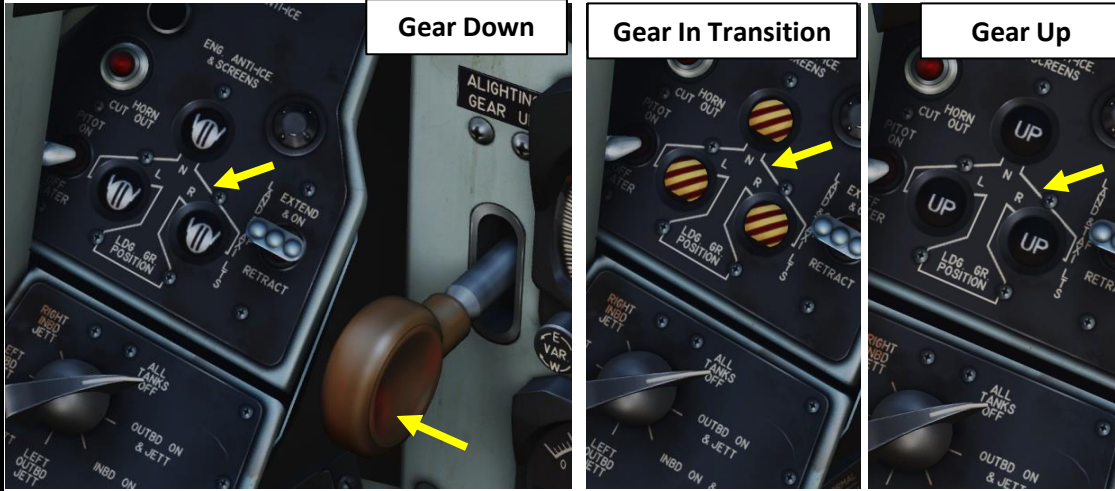

TAKEOFF

11. Once airborne, set your flaps lever to UP to retract flaps. Confirm flaps are retracted by checking the wings, then set flaps lever to “NEUTRAL”. Flaps should be fully retracted below 140 kts.
12. After takeoff, maintain the preset climb angle using trim. For optimal climb, i.e. a full power rate of climb with minimum airspeed drop, accelerate to 455 kts IAS (indicated airspeed) at sea level and start climbing at such a rate so that airspeed decreases by 50 knots for every 10,000 foot increase in altitude.

Best Climb Speed	
<u>Altitude (ft)</u>	<u>Indicated Airspeed (kts)</u>
Sea Level	455
5000	430
10000	400
15000	385
20000	350
25000	325
30000	300
35000	285
40000	255
45000	230
50000	205
55000	180



CLIMB

13. Altitude gain is defined by a number of inter-related tactical parameters: the time of climb, the distance covered by the plane while gaining altitude, and the fuel amount for reaching the defined altitude. The figure below shows the relationship between the parameters and the method for calculating them.

Graph for Calculating Climb Parameters

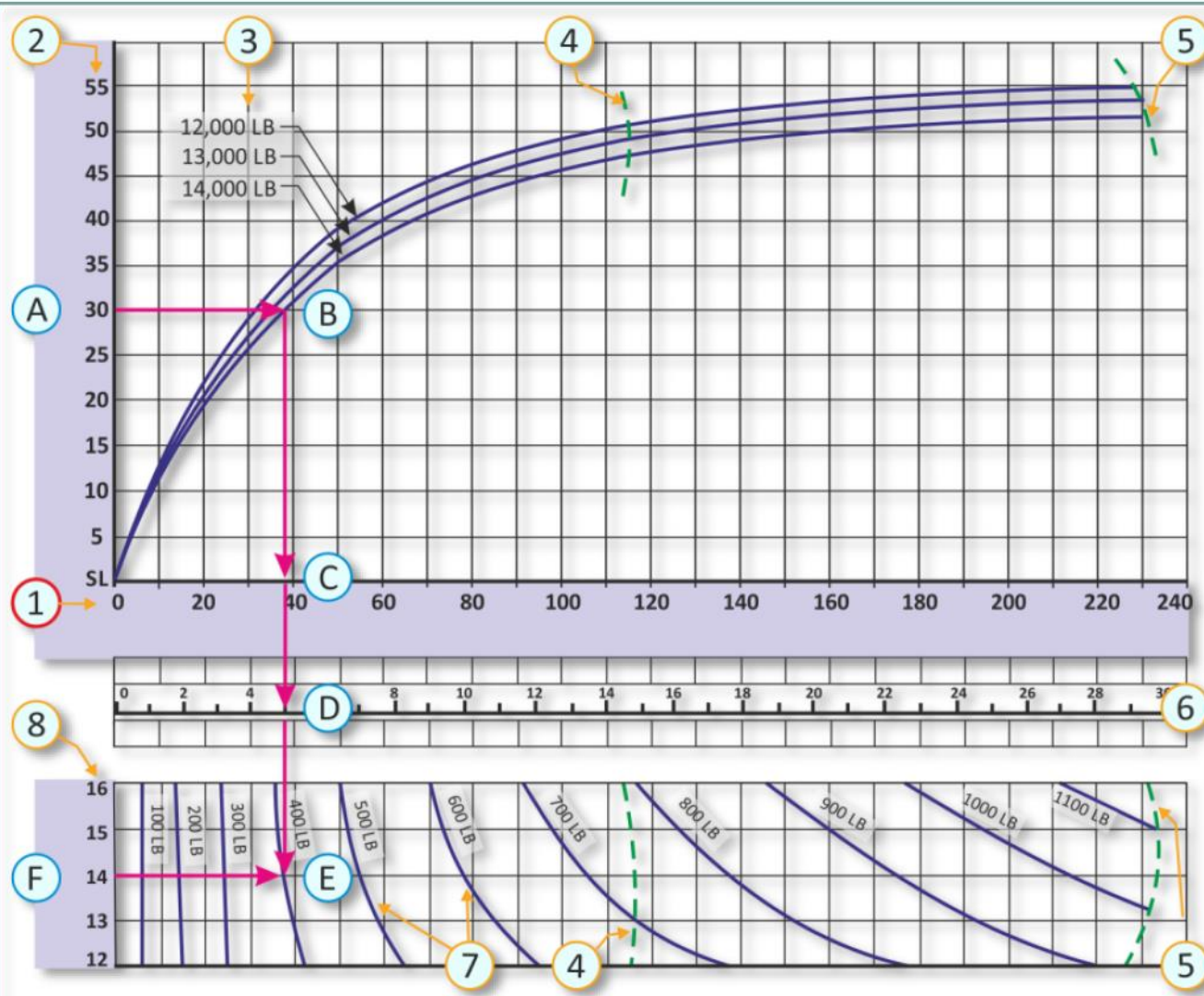

Procedure for determining climb parameters (example)

The airplane has a takeoff weight of 14,000 lbs. The required altitude is 30,000 ft. Calculate the climb parameters.

1. Find the required altitude on axis (2), point (A) and draw a horizontal line until it intersects the 14,000 lbs takeoff weight curve (3), point (B). Then draw a perpendicular line vertically down until it intersects with axis (1), point (C). This gives a calculated climb distance of 38 nm.
2. From point (C), continue drawing the vertical line until it intersects with the time scale (6), point (D). This gives a calculated climb time of 5 minutes.
3. From point (D), continue drawing the vertical line down until it intersects the fuel used curve (7), point (E). Then draw a horizontal line from the takeoff weight axis (8), point (F) to the fuel used curve (7), point (E). In this case, the fuel used during the climb is determined to be 400 lbs. If a point is between fuel used curves, determine an approximate amount of fuel used based on where the point (E) is located between the curves.

1. Air distance, nautical miles
2. Altitude, thousands of ft
3. Gross weight (sea level)
4. Optimum range altitude
5. Service ceiling
6. Time of climb, minutes
7. Fuel used
8. Gross weight, thousand of lbs (sea level)

PART 5 - TAKEOFF

**F-86F
SABRE**





F-86F
SABRE

LANDING

PART 6 - LANDING



LANDING

1. For effective deceleration, especially during descent, extend the speed brakes and decelerate to 185 knots IAS (gear and flaps-down limit speed).
2. At IAS below 185 knots, extend the landing gear and flaps. Check locking of landing gear by watching the position indicators
3. Hold IAS at approximately 140 knots after gear and flaps are lowered.
4. Continuously monitor the glideslope angle (by verifying the touch-down point near the runway threshold) and approach direction.
5. When close to touch-down, gradually decrease the sink rate until the aircraft is flying level at approximately 3-5 feet above the runway and decelerating. Decrease rpm by setting the throttle to IDLE.
6. As the aircraft continues to descend, pull slowly back on the control stick to achieve a landing on the two main wheels at approximately 115 knots IAS.
7. During the first part of the landing roll, keep the nose wheel up for “airbraking” (using the drag generated by the wings to act like an additional airbrake).
8. After the nose wheel touches down, start braking with the main wheels (amount of braking needed is dependent on the length of remaining runway).
9. After the aircraft has turned off the runway, retract flaps and speed brakes.
10. Taxi to the parking area.

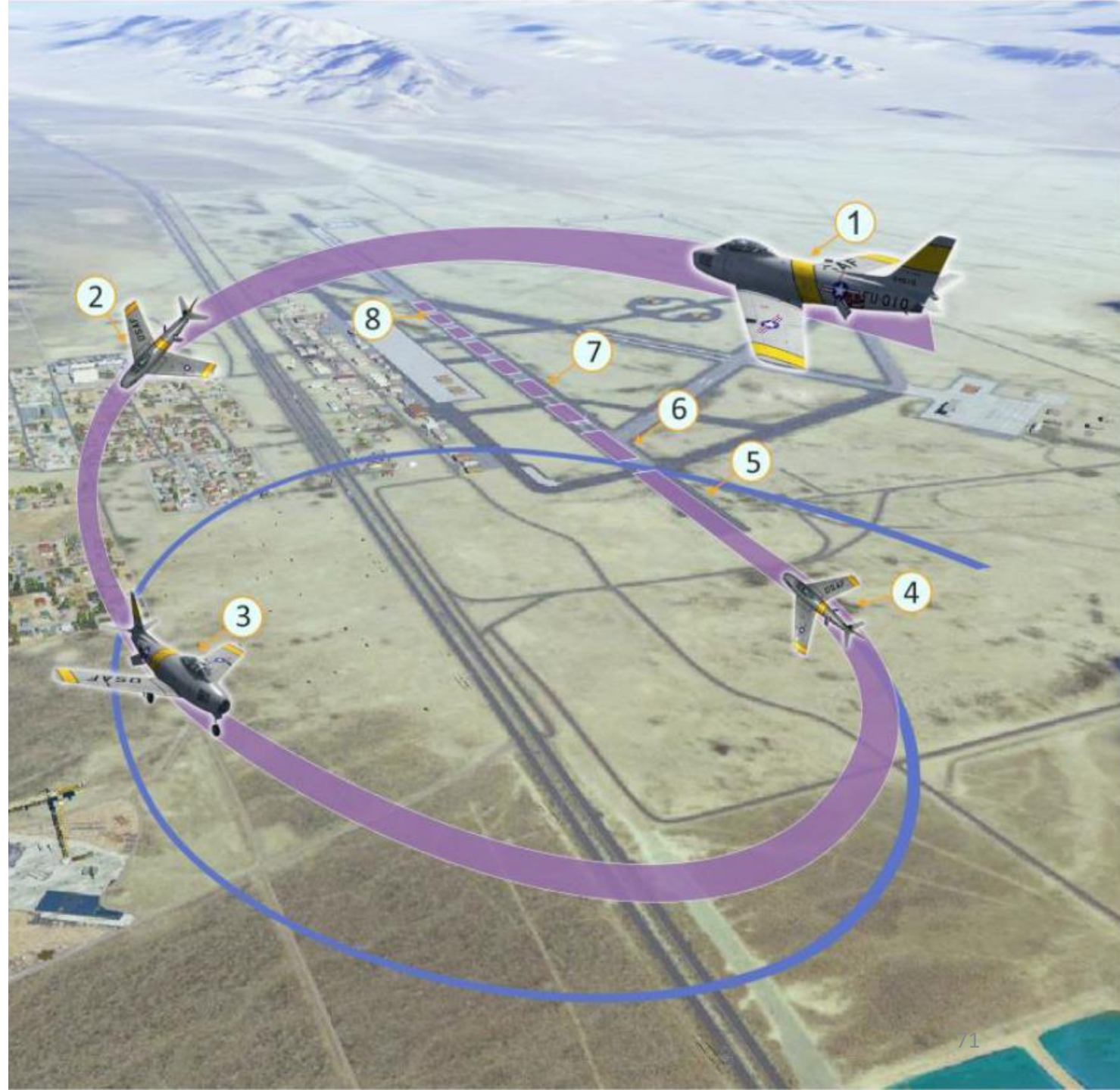

LANDING



LANDING







GENERAL ELECTRIC J47-GE-27 ENGINE

The General Electric J47 engine has a 12-stage axial compressor and a single-stage axial turbine. In the front, the aircraft has an air intake. The air is sucked into it, goes through the air channel under the cockpit and reaches the engine. From there, the air is directed to the axial-flow compressor where it is compressed. Compressed air, mixed with fuel spray, goes to the eight-section combustion chamber.

While the engine is started and running, this mixture is continuously burning. From the combustion chamber, hot gases pass through a single-stage turbine into the exhaust nozzle which is an expanding pipe. In the exhaust pipe, hot gases are accelerated and form a jet stream (jet thrust).

The turbine is rotated by the energy of the hot gases passing through it and mechanically transmits rotation to the compressor and engine system components. The cockpit and fuel tanks are separated from the engine compartment by a special protective wall. The engine compartment itself is divided by a fire-resistant wall. The forward part is relatively cool and includes a compressor and engine system components. The rear part hosts the combustion chamber, turbine, and exhaust nozzle.

J57-HR-27 Engine Characteristics

Maximum Thrust	5970 lbf, 26.56 kN at 7950 RPM
Compressor	12-stage axial compressor
Turbine	Single-stage axial
Specific Fuel Consumption	1.014 lb/lbf/hour
Airflow Rate	92 lb/s, 42 kg/s
Overall Pressure Compression Ratio	5.35
Tc Max	1170 Kelvins
Length	145 in / 3700 mm
Diameter	36.75 in / 933 mm
Dry Weight	2554 lbs / 1158 kg
Service Life	200 hours

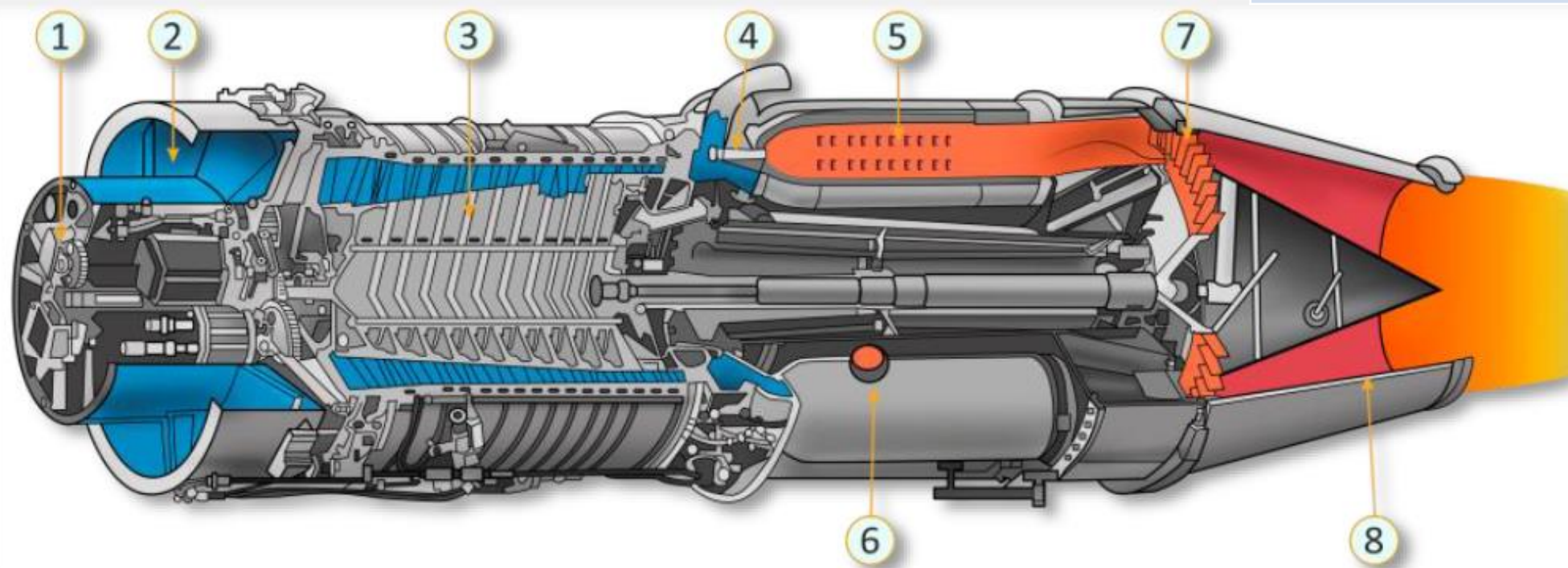

1. Gearbox
2. Air flow channel
3. Compressor
4. Fuel nozzle
5. Combustion chamber
6. Ignition system
7. Turbine
8. Exhaust nozzle



F-86F
SABRE

PART 7 – ENGINE & FUEL MANAGEMENT

ENGINE INDICATIONS

Here is an overview of the different engine parameters you need to monitor:

- Tachometer: Engine RPM (%)
- Exhaust Gas Temperature (EGT) in deg C
- Fuel Flow Indicator (x1000 lbs/hour)
- Engine Oil Pressure (psi)

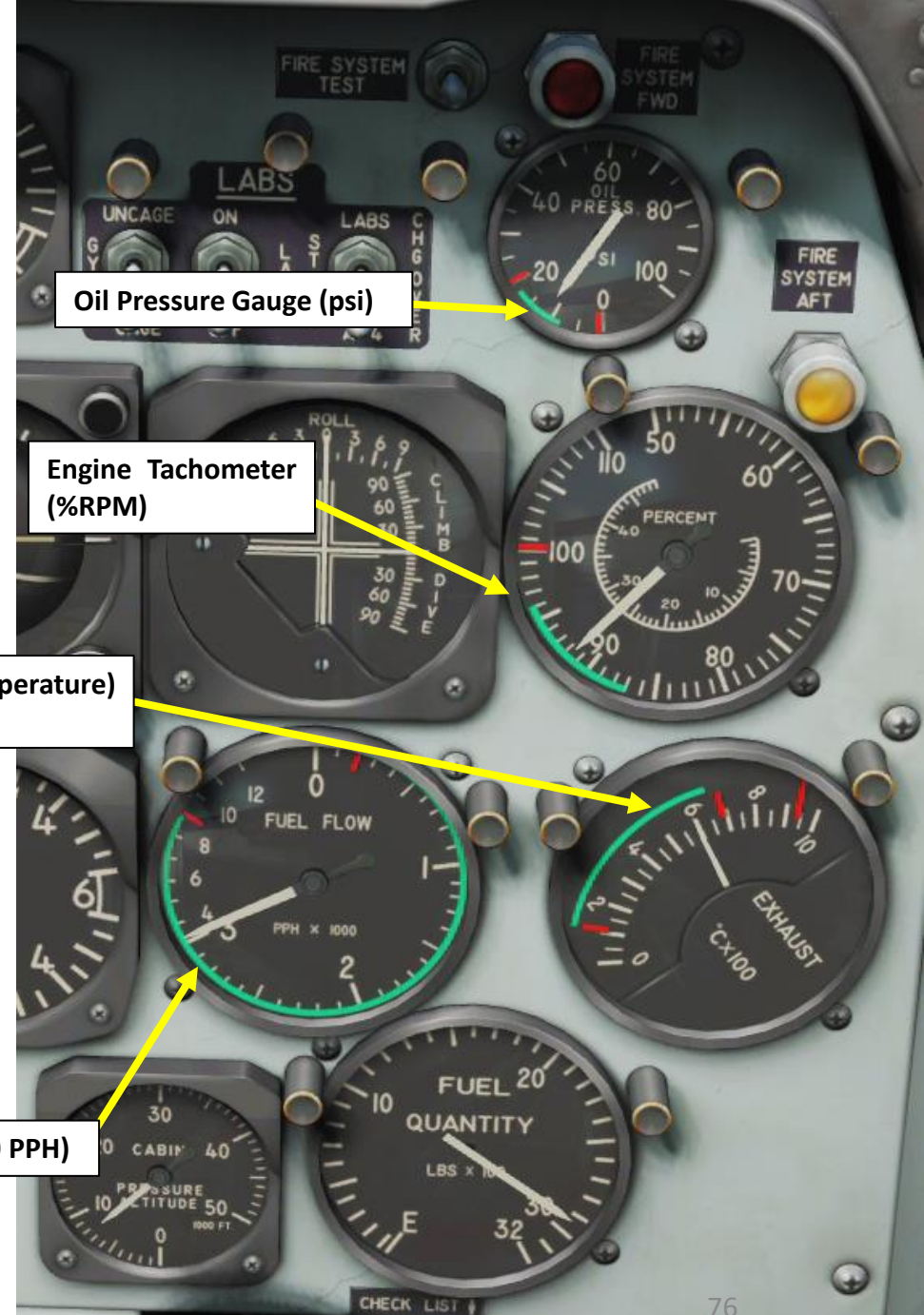

ENGINE CONTROLS & MANAGEMENT

The engine is managed with the **throttle**.

Engine RPM Settings

Recommended engine RPM setting during normal flying is between **85 % and 95 % RPM**.

Military Thrust is defined as the thrust obtained at full open throttle (100% engine rpm or 690°C exhaust temperature, whichever is lower) and is limited to 30 minutes.

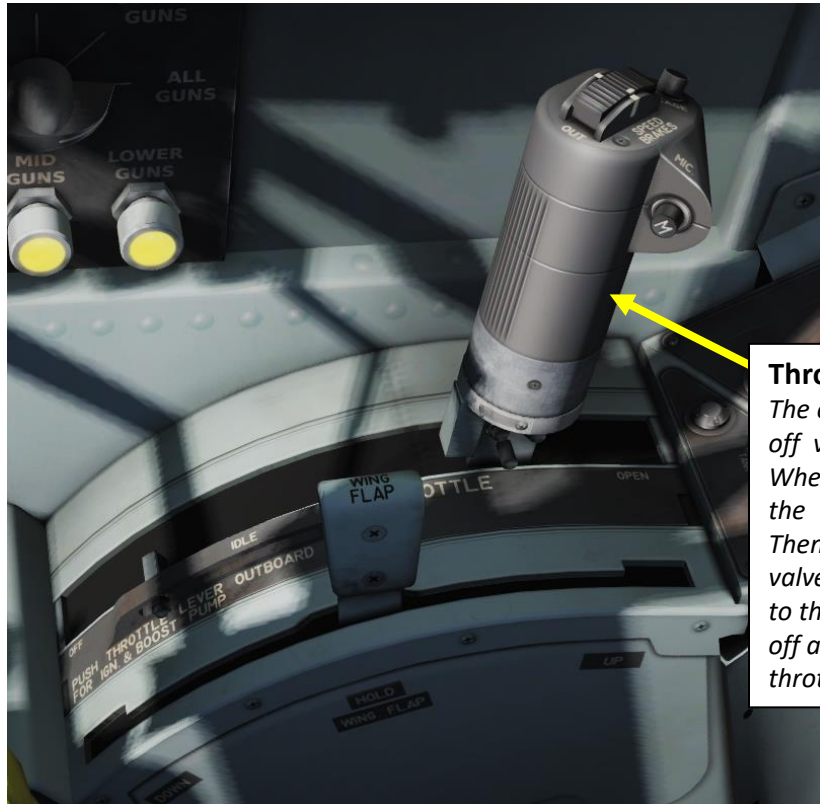

Throttle

The engine throttle is mechanically connected to the fuel shut-off valve and to the main and emergency fuel controllers. When the main switch is turned on, the power is supplied to the engine starting system and to the fuel shut-off valve. Then, as the throttle moves from OFF to IDLE, the fuel shut-off valve opens. Fuel is supplied to the engine starting system and to the engine itself (the ignition system automatically switches off as the RPM reach approx. 23%). When the engine is on, the throttle position determines the target RPM.

Engine Master Switch

The engine master switch is a two-position switch. In the ON position, it supplies electrical power for opening of the fuel supply system's shut-off valve and supplies the engine ignition and starting system. As long as the throttle is OFF, the fuel shut-off valve is closed (regardless of the position of the switch), and fuel pumps are disengaged.



Stop-Starter Button



F-86F
SABRE

ENGINE CONTROLS & MANAGEMENT

Keep an eye for exhaust temperature during combat, especially if you go full throttle (100 % RPM) for an extended period of time. Prolonged overheating of the engine will result in catastrophic engine failure.

The only temperature you need to keep an eye on is the exhaust gas temperature (EGT). Make sure the temperature is within serviceability and safety limits (green). Engine temperature can only be controlled by reducing or augmenting engine RPM with the throttle.

EGT (Exhaust Gas Temperature) Limits:

- Max EGT should be **685 deg C** at all times
- During Engine Start-Up to IDLE RPM (within 2 minutes): 950°C or above for 2 seconds or more.
- All Engine Operation (Except for Start-Up) :
 - 690°C to 750°C for 40 seconds or more;
 - 750°C to 800°C for 10 seconds or more;
 - 800°C or above for 2 seconds or more.

Engine oil pressure limits for various engine rpm settings are given in the figure to the right.

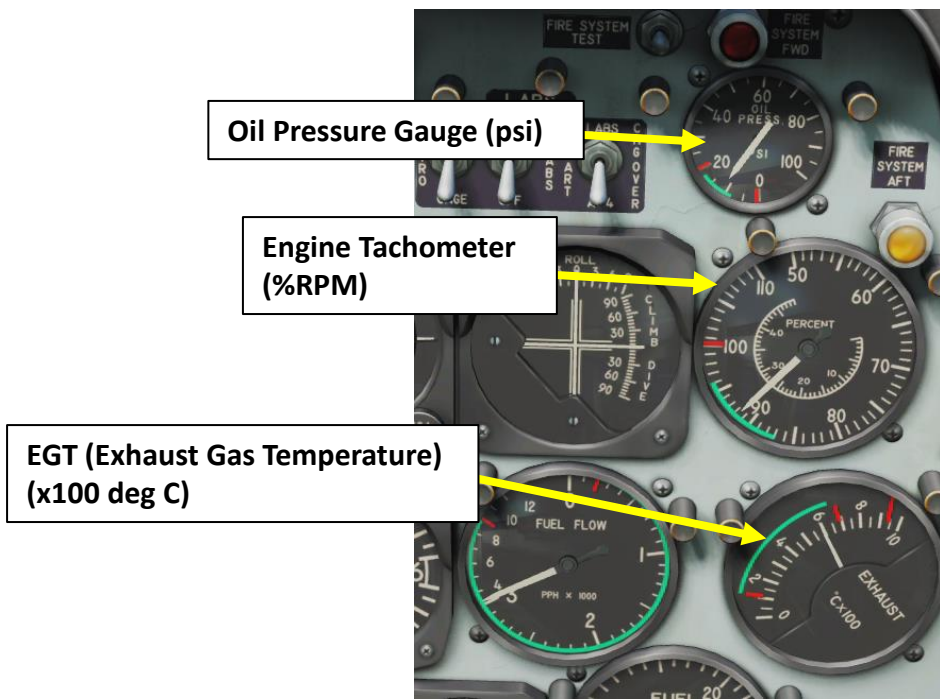

Engine Oil Pressure Limitations

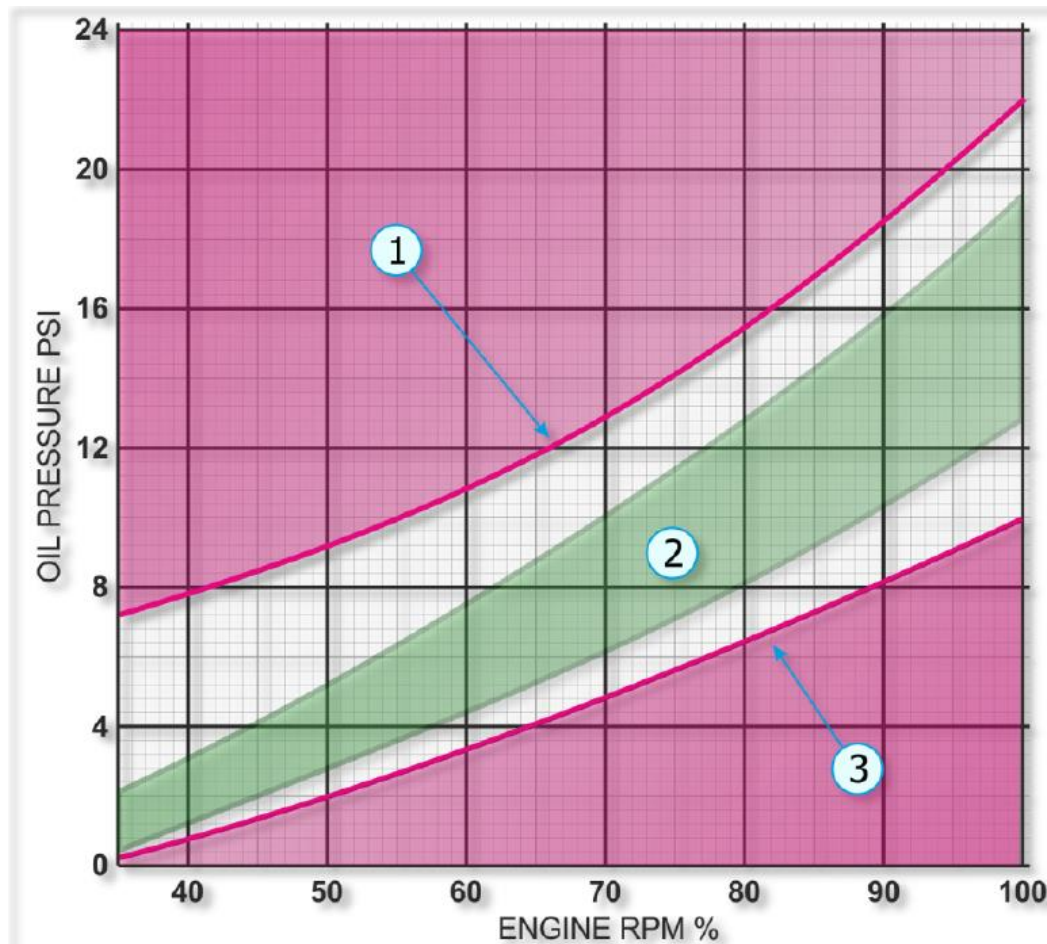

1. Upper limit of oil pressure values
2. Area of normal oil pressure values
3. Lower limit of oil pressure values



ENGINE ANTI-ICE & ENGINE PROTECTIVE SCREENS

Protection of the engine from ice build-up and ground debris is done via the three-position anti-ice and protective screen switch in the cockpit.

- In the **EXTEND (FWD) position**, the engine inlet protective screens are extended and prevent the ingress of foreign objects during engine operation on the ground.
- In the **RETRACT (MIDDLE) position**, the protective screens are retracted.
- During icing conditions in flight, the switch must be set to **ANTI-ICE (AFT) position**.

All the parts of the engine inlet with an exposed frontal area have anti-ice protection except for the inlet protective screens.

The engine inlet front lip and compressor inlet guide vanes are continuously and automatically heated by the compressed air when the ANTI-ICE (AFT) position is selected on the anti-ice and protective screen switch.

After the anti-ice system is turned on, the hot air from the compressor starts flowing to the engine inlet front lip and the engine protective cone. To prevent overheat of the fairing, there is a thermal fuse in the system with a thermostwitch that controls hot air supply. When the anti-ice system is turned on, the engine inlet protective screens are automatically retracted in order to prevent ice formation on them.

The engine inlet is equipped with a system of eight protective screens that protect the compressor from ingestion of foreign objects on the ground (the ingestion of foreign objects is not simulated in the game). The screens are extended simultaneously into the engine inlet channel when the EXTEND (FWD) position is selected on the anti-ice and protective screen switch. In flight, they must be retracted using the RET position of the switch in order to prevent ice from forming on them and causing engine damage.

Engine Anti-Ice & Screen Switch





ENGINE COMPRESSOR STALL

Compressor stall may occur when you move the throttle too quickly. You will notice a sudden loss in engine RPM. The J47 engine is slow to respond to throttle input, so it should be treated gently. In case of compressor stall, pull back the throttle to IDLE and slowly throttle up. Major compressor failure may result in an engine flameout.

A **compressor stall** is a local disruption of the airflow in the compressor of a gas turbine or turbocharger. A stall that results in the complete disruption of the airflow through the compressor is referred to as a **compressor surge**. The severity of the phenomenon ranges from a momentary power drop barely registered by the engine instruments to a complete loss of compression in case of a surge, requiring adjustments in the fuel flow to recover normal operation.

Compressor stall was a common problem on early jet engines with simple aerodynamics and manual or mechanical fuel control units, but has been virtually eliminated by better design and the use of hydromechanical and electronic control systems such as Full Authority Digital Engine Control (FADEC). Modern compressors are carefully designed and controlled to avoid or limit stall within an engine's operating range.

Engine Stall Signs (possible manifestation of one or more issues at the same time):

- Engine RPM hang (reduction)
- RPM unresponsiveness to throttle movements
- Engine overheat.

Engine Stall Recovery Actions:

1. Move throttle to idle until normal temperature and RPM values are reached (possible before the stable RPM reduction to idle position).
2. Move throttle smoothly after.

ENGINE RELIGHT (AIR START) PROCEDURE

If you have an engine failure in flight:

1. Do not panic
2. Cut throttle and set it to "OFF" (Press "END" key twice)
3. Put the Sabre's nose down and increase speed between 185 and 225 kts
4. Make sure the Master Switch and Battery Switch are both ON
5. Switch ON Emergency In-Air Ignition Switch (FWD). Lift red safety cover first.
6. Switch ON Emergency Fuel Switch (UP)
7. Set throttle to IDLE position (Press "HOME" key twice)
8. Once engine is spooling up (90+ % RPM), Switch OFF (AFT) Emergency In-Air Ignition Switch
9. Once smooth engine operation is established, switch OFF the Emergency Fuel Switch

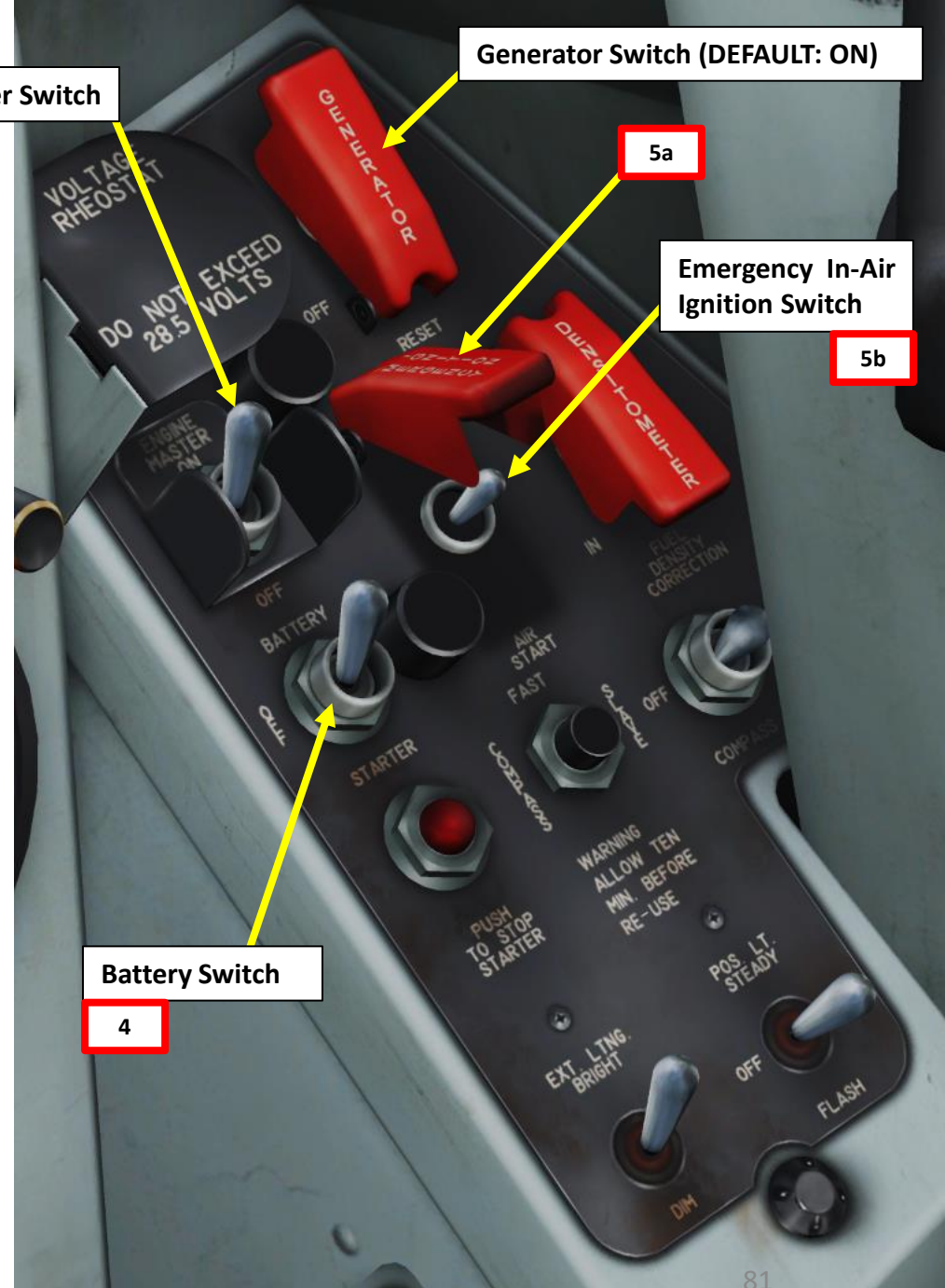
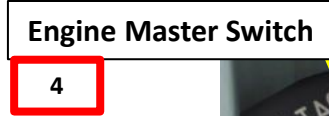
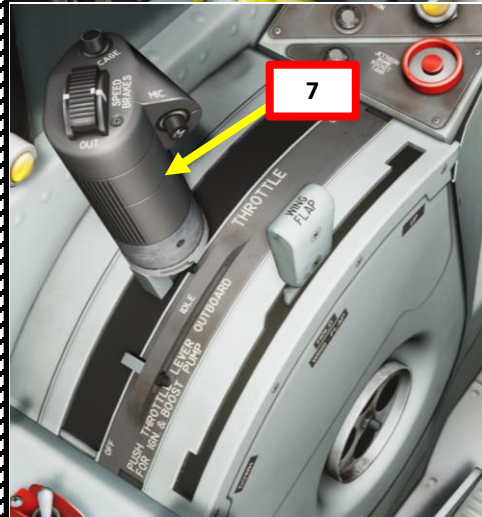
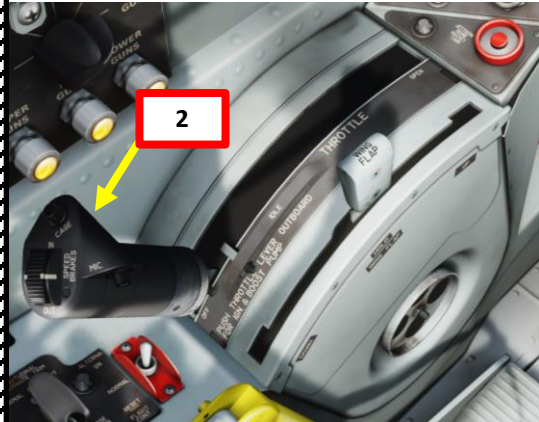



F-86F
SABRE

FIRE DETECTION & EMERGENCY PROCEDURE

The fire detectors are installed in the forward (compressor and gearbox) and aft (combustion chamber and tail pipe) engine sections separated by a firewall.

Important Note: Unlike modern aircraft, the Sabre's **engine does not have a fire extinguishing system**. This means that if your engine catches fire, you can pretty much kiss your ass goodbye.

Engine fire during takeoff

Illumination of the forward fire warning light during takeoff indicates a fire in the forward engine section, necessitating immediate action. Illumination of the aft fire warning light indicates an overheat condition or possible fire in the aft section. The exact procedure to follow will vary with each set of circumstances and will depend upon altitude, airspeed, length of runway, overrun clearing remaining, availability of arresting barrier, location of populated areas, etc.

Fire while airborne

If either fire warning light comes on while the plane is airborne and there is insufficient runway and clear overrun available to abort the takeoff, the following procedure is recommended:

1. Jettison external stores.
2. Set power to maximum and climb to a safe ejection altitude.
3. If aircraft is ON fire, EJECT.
4. If aircraft is not on fire, adjust throttle to minimum practical power and land as soon as possible. If existence of fire cannot be confirmed, maintain a safe ejection altitude at minimum practical power. Establish controllability of the airplane and try to obtain assistance from other airplanes in the area in determining existence of fire. If no assistance is available, reconfirm controllability before descent below safe ejection altitude and land as soon as possible.

Engine fire during flight

If either fire warning light comes on, proceed as follows:

1. Set throttle to IDLE.
2. If aircraft is ON fire, EJECT. A fire can be determined by a report from another airplane, abnormal instrument readings, lack of response to flight or engine controls, explosions, unusual noise, vibration, fumes, heat, cockpit smoke, or trailing smoke observed during a turn.
3. If aircraft is not on fire, land as soon as possible using minimum practical power.

Fire Detection System Test Switch

Engine Fire (Forward Section) Warning Light

Engine Fire (Aft Section) Warning Light



FUEL TANKS & FUEL INDICATORS

The onboard fuel is stored in four tanks – two (forward and rear) in the fuselage and one inside each half-wing. To increase the onboard fuel reserve, external tanks can be installed – two under each half-wing. The inboard pylons can take 450 litre (120 gallon) tanks. The outboard pylons can take 760 litre (200 gallon) tanks.

The fuel quantity indicator only starts showing a reading change after all fuel in the external tanks is depleted and fuel in the internal tanks starts to be consumed. In other words, the fuel gauge only displays internal fuel.

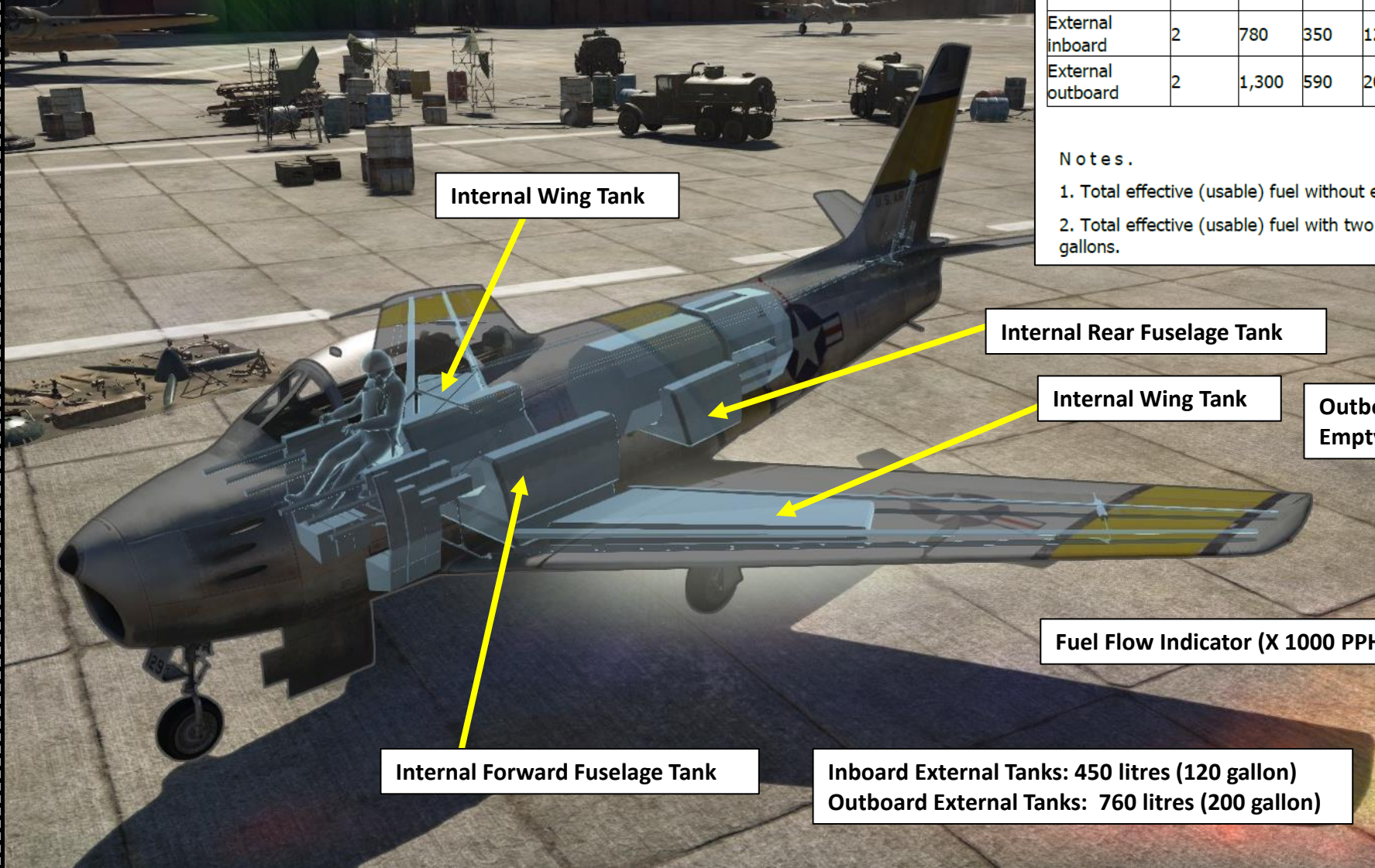
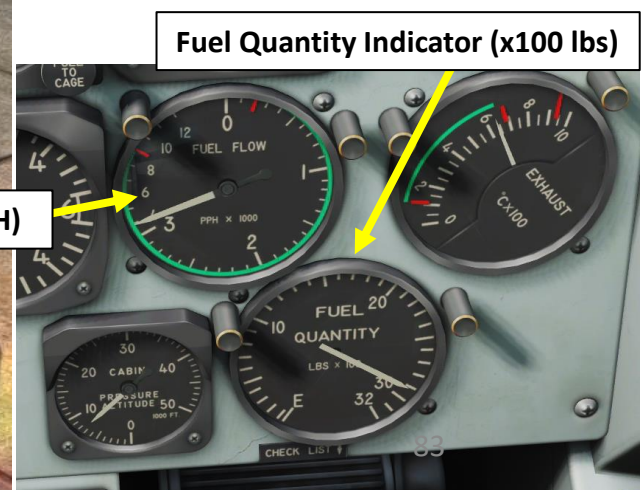
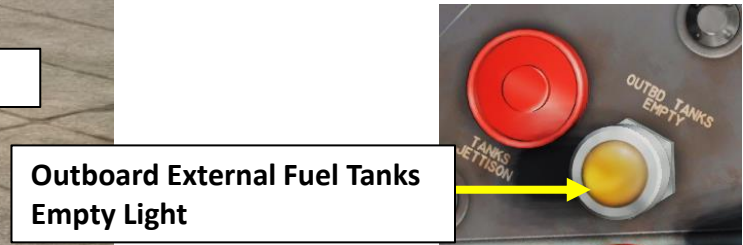

Table 5.1

Tank	Number of tanks	Effective (usable) fuel (for each tank)				Full fuel (for each tank)			
		pounds	kg	gallons	liters	pounds	kg	gallons	liters
Forward fuselage	1	1,274	580	196	740	1,306	592	201	760
Rear fuselage	1	682	310	105	400	689	312	106	402
Inside wing	2	435	197	67	250	442	200	68	257
External inboard	2	780	350	120	450	780	350	120	450
External outboard	2	1,300	590	200	760	1,306	592	201	760

Notes.

1. Total effective (usable) fuel without external fuel tanks: 2,827 pounds/435 gallons.
2. Total effective (usable) fuel with two external 120 gallon fuel tanks: 4,287 pounds/675 gallons.



Inboard External Tanks: 450 litres (120 gallon)
Outboard External Tanks: 760 litres (200 gallon)

FUEL AUTOMATION SYSTEM

The purpose of the main fuel automation system is to ensure stable performance of the engine on the ground during taxi and in flight. The main elements of the fuel automation system are the fuel pump, the digital fuel regulator, and the fuel control valve. The fuel pump is powered by mechanical energy transmitted from the engine gearbox (engine rotor).

The efficiency of the fuel pump depends only on the engine RPM. The amount of fuel coming into the engine is controlled by the fuel regulator which is mechanically connected with the engine throttle. It controls the inflow of fuel to the engine depending on the position of the engine throttle that corresponds to certain engine RPM. The fuel regulator also maintains the engine RPM determined by throttle input in case of a change in flight conditions (altitude and airspeed). The fuel does not go through the regulator itself. A change of the fuel flow rate is executed by the fuel control valve that is actuated by the fuel regulator.

The fuel control valve directs some of the fuel to the engine and returns some of the fuel back to the fuel pump through the return line. The fuel automation system controls engine RPM in a range of 30% to 100%. Idle RPM ensure a continuous stable burning in the combustion chamber at the lowest possible RPM. With an increase of altitude, the content of oxygen in the air decreases, so the engine needs more air for stable performance. The engine automation system increases the idle RPM with an increase of altitude.

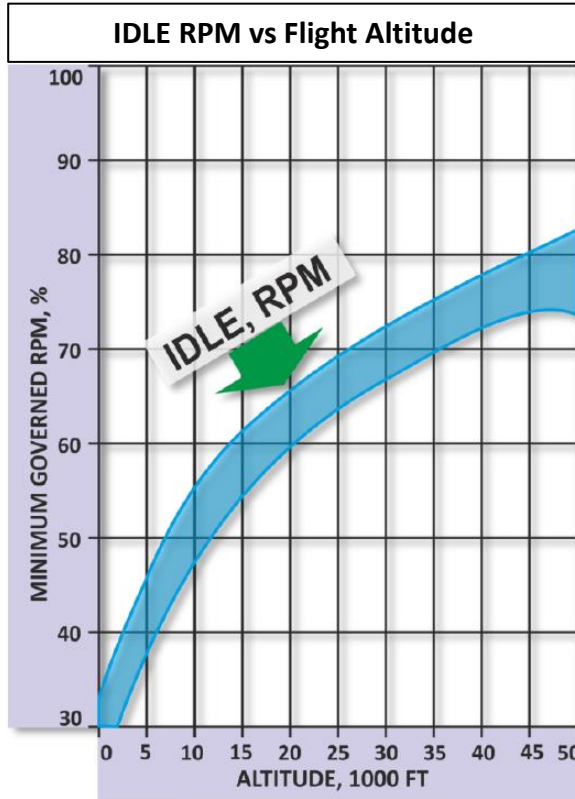

1. Fuel from fuel supply
2. Shut-off valve
3. Fuel filter
4. Engine master switch
5. Dual fuel pump
6. Emergency fuel switch
7. Emergency fuel regulator
8. Fuel filter
9. Main fuel regulator
10. Engine throttle
11. Cut off valve
12. Fuel flow meter
13. Small manifold
14. Flow divider
15. Big manifold
16. Fuel nozzle

- A. Supply line
- B. Emergency fuel automation system supply line
- C. Main fuel automation system return line
- D. Emergency fuel automation system return line
- E. Electrical connection
- F. Mechanical connection
- G. Check valve

J47 Engine Fuel Automation System

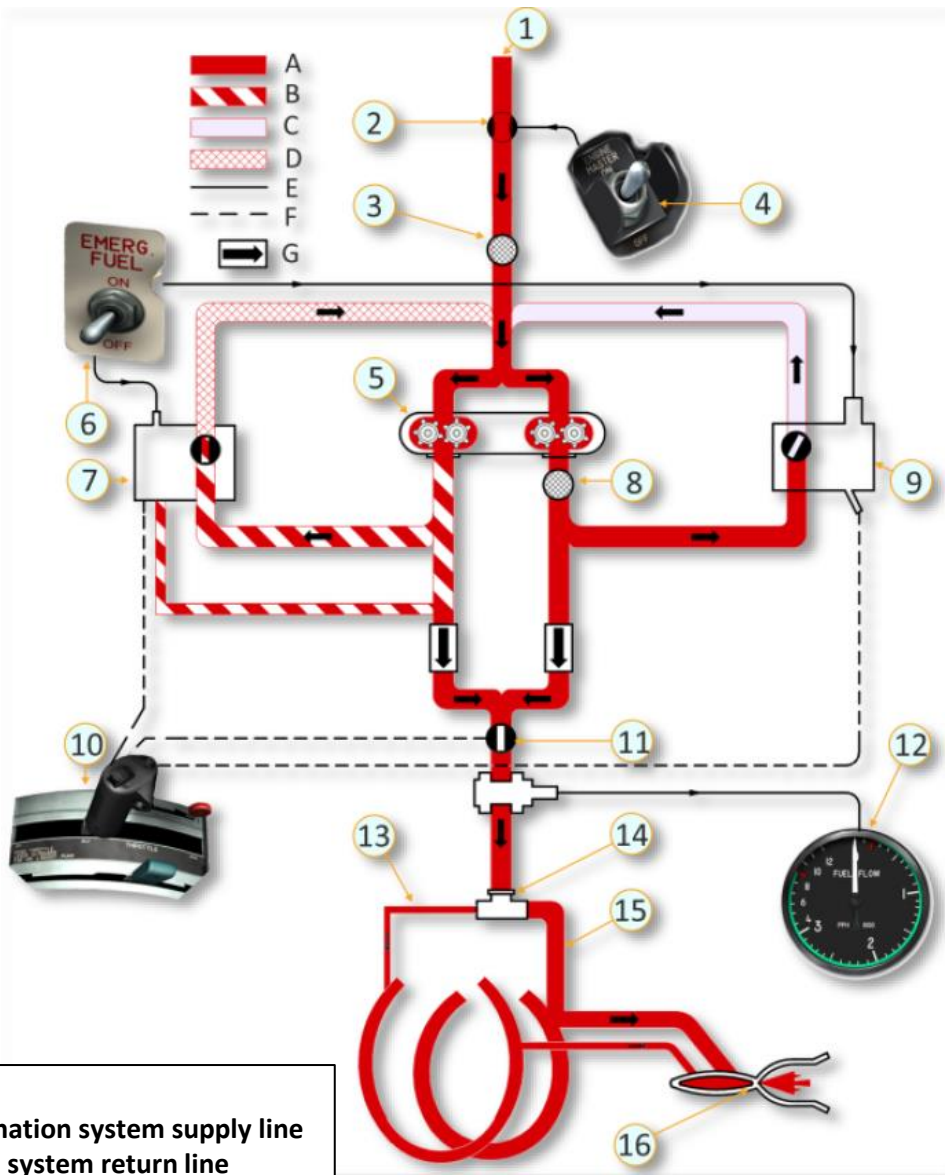

EMERGENCY FUEL AUTOMATION SYSTEM

The emergency fuel automation system consists of a fuel pump and an emergency fuel regulator with the engine fuel supply control valve. During normal operation of the main fuel automation system, the emergency fuel automation system is off and the fuel supply control valve is closed. If the main fuel automation system fails and the EMERG FUEL switch is switched on, the emergency fuel system valve receives a signal for opening, the main fuel automation system valve is closed, and the main system is completely cut off.

Main fuel automation system failure is seen as a broken connection between the position of the throttle handle and engine RPM, i.e. if movement of the throttle handle does not change (increase or decrease) engine RPM, then there is a failure in the main fuel automation system.

The emergency fuel regulator maintains the target RPM in case of a change in altitude, but does not take into account changes of airspeed.

Note. The emergency fuel regulator maintains the engine RPM in a range of 30% - 99% at a temperature of ~38°C (100°F). In case of temperature decrease, the upper RPM limit decreases too.



Emergency Fuel Switch
UP: ON
DOWN: OFF



FUEL MANAGEMENT

The first tanks to be depleted are the external tanks. To ensure fuel transfer from these tanks, they are pressurized by air downstream of the compressor. Then approximately 80 litres (20 gallons) of fuel from the upper part of the forward tank are used (gravity feeding the lower part of the tank). Then a transfer pump in the rear tank turns on and starts pumping fuel through the lower section of the forward tank into the upper section. This cycle repeats until the fuel in the rear tank starts swaying. Then the fuel from the internal wing tanks starts gravity feeding the lower part of the forward tank. This fuel management schedule allows the forward center of gravity to be maintained.

The automatic fuel depletion sequence is ensured by the difference of pressure in the tanks and the operation of the transfer pump in the rear fuselage tank. In case of transfer pump failure, the force of the pumps in the forward tank is sufficient for creating fuel flow from all internal tanks to the supply tank resulting in stable operation of the engine.

- A. High-pressure fuel line
- B. Fuel transfer
- C. Air pressurization
- D. Regulator valves
- E. Booster / transfer pump
- F. Electrical coupling
- G. Mechanical coupling
- H. Shutoff valve

- 1. Air downstream of compressor
- 2. Drop tank control panel
- 3. Left outboard external tank
- 4. Left inboard external tank
- 5. Fuel level metering valve
- 6. Forward (upper) fuselage tank
- 7. Right inboard external tank
- 8. Right outboard external tank
- 9. Left wing tank
- 10. Right wing tank
- 11. Engine throttle
- 12. Forward (lower) fuselage tank
- 13. Fuel quantity indicator
- 14. Rear fuselage tank
- 15. Fuel control switch
- 16. Fuel control system power supply

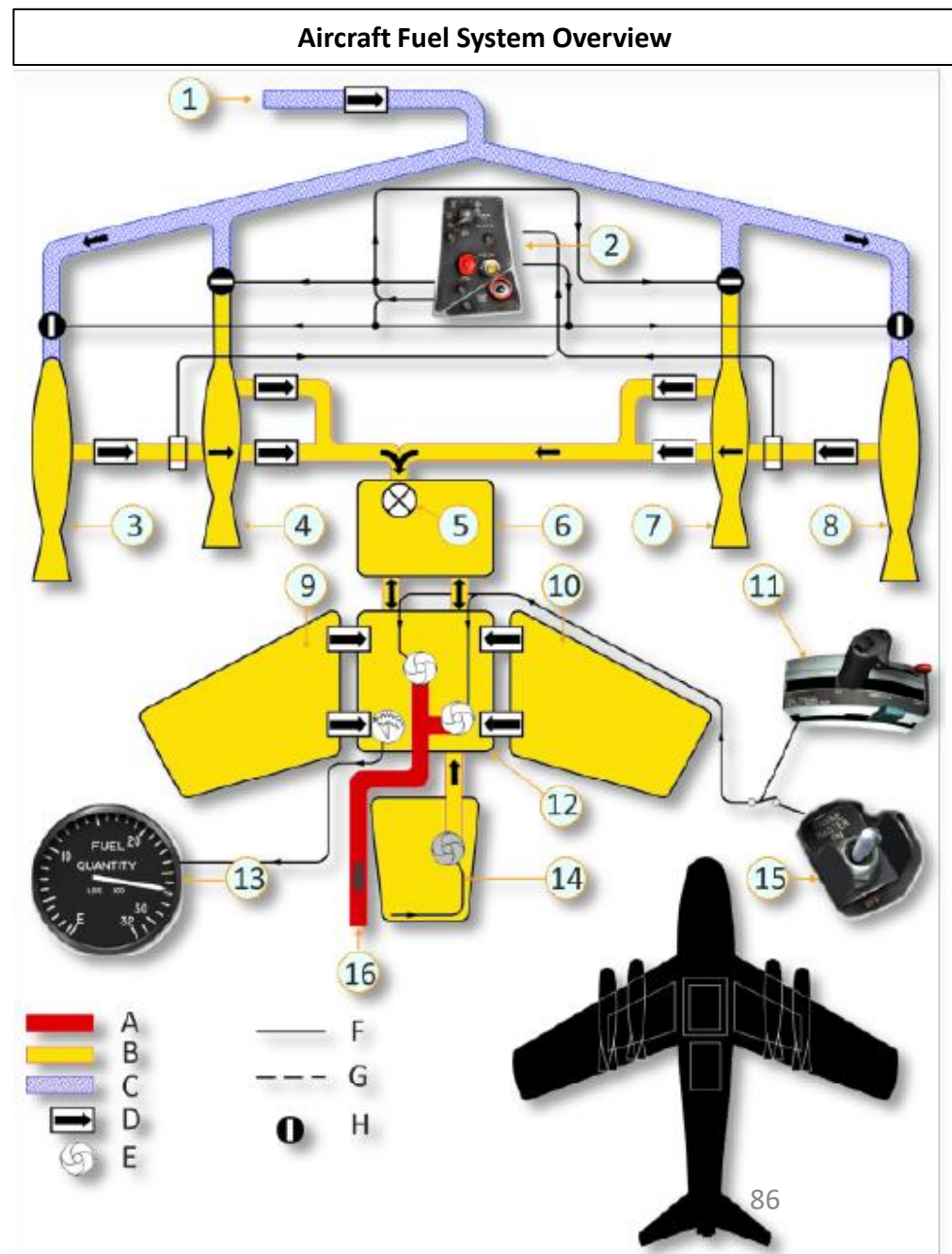



FUEL MANAGEMENT

The fuel tank usage and jettison is controlled by the drop tank control panel on the left slope panel in the cockpit. Both usage and jettison of external fuel tanks are controlled by putting the wafer switch in the respective position.

- Setting the switch to the **OUTBD ON & JET position** pressurizes the external outboard tanks by opening the shutoff solenoid valves and allowing compressed air from behind the compressor to flow to the external fuel tanks.
- Setting the switch to the **INBD ON & JET position** pressurizes the external inboard tanks. To keep the center of gravity in the right position and to ensure normal roll control, it is recommended to use the outboard external tanks first and then the inboard external tanks.

Even after fuel consumption from the internal tanks begins, the wafer switch must be kept in the INBD ON & JET position. This guarantees complete fuel depletion from the inboard external tanks (there is no indication of fuel depletion for these tanks unlike for the outboard external tanks).

- When the switch is in the **ALL TANKS OFF position**, the external tanks are no longer pressurized and fuel is not supplied from them.

Fuel Tank Selector Switch

- *ALL TANKS OFF = SAFETY (Tanks will not drop, fuel is taken from internal tanks)*
- *OUTBD ON & JETT = Fuel taken from Outboard external tanks, jettison Outboard Tanks Only*
- *INBD ON & JETT = Fuel taken from Inboard external tanks, jettison Inboard Tanks Only*
- *Other positions are self-explanatory*

Very important note: this switch must be used to choose where the fuel pumps will take fuel from. If you leave the switch to "ALL TANKS OFF", your fuel pumps will use your internal tanks rather than your external tanks.



Outboard External Fuel Tanks Empty Light

EXTERNAL FUEL TANK OPERATION

1. To consume fuel from external tanks, set Fuel Tank Selector switch to:
 - OUTBD ON & JETT to consume fuel from Outboard external tanks
 - INBD ON & JETT to consume fuel from the Inboard external tanks
2. There is no separate fuel quantity gauge for drop tanks. When drop tanks are carried, the fuel quantity gauge will not indicate a decrease in fuel supply until the drop tank fuel has been consumed and the engine begins to use internal fuel.
3. When outboard external fuel tanks are empty, the OUTBD TANKS EMPTY light illuminates. Inboard external fuel tanks do not have an indication to show when they are empty.
4. When outboard external tanks are empty, you can either:
 - a) Set Fuel Tank Selector Switch to INBD ON & JETT if inboard tanks are equipped and filled with fuel, or;
 - b) Set Fuel Tank Selector Switch to ALL TANKS OFF. This will consume fuel from the aircraft inner fuel tanks.

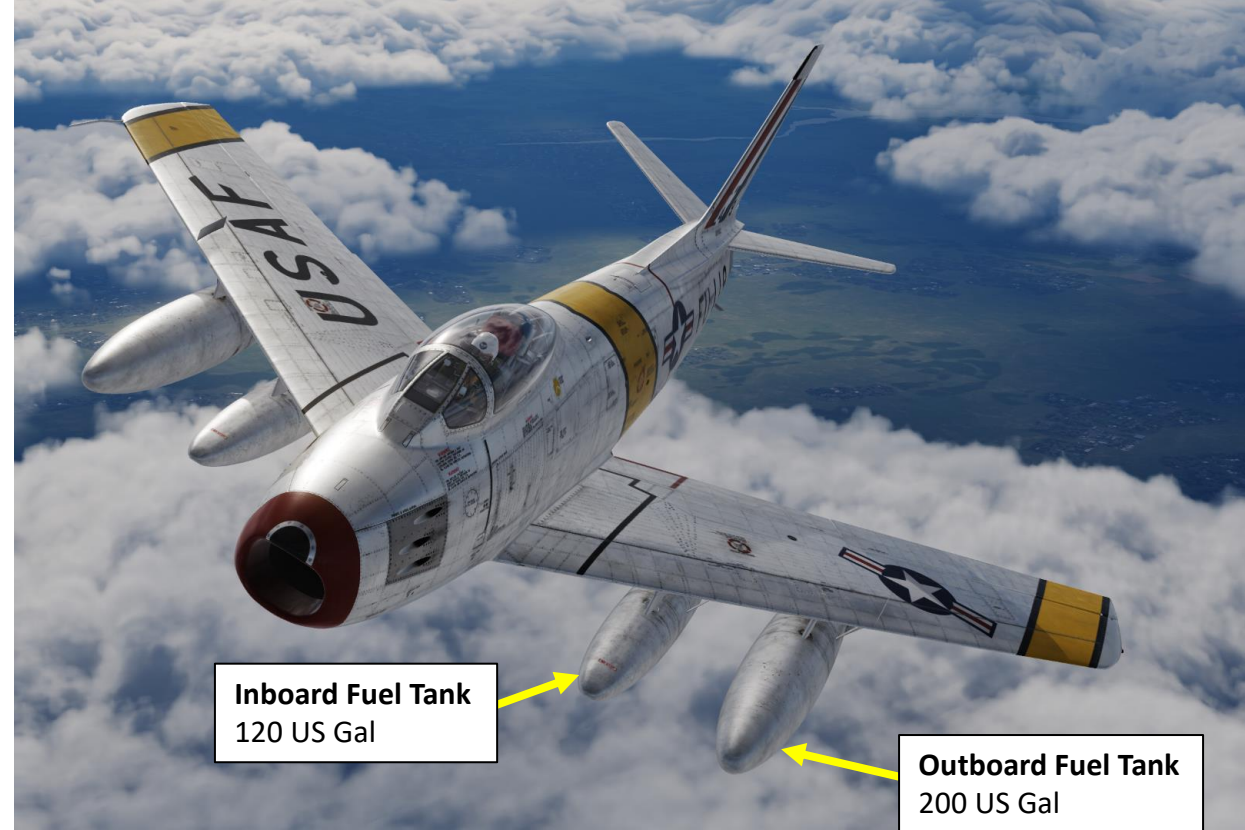



F-86F
SABRE

HOW TO JETTISON EXTERNAL FUEL DROP TANKS

1. Set Fuel Tank Selector Switch to the external drop tanks you want to jettison. Since we want to jettison outboard external drop tanks, we will set the selector to OUTBD ON & JETT.
 - If we wanted to jettison inboard drop tanks, we would select INBD ON & JETT.
2. Press Jettison Fuel Tanks Button.
3. For the jettison of inboard tanks, the inboard pylon locks are opened by an electrical signal. For the jettison of outboard tanks, the electrical signal opens the locks and, additionally, activates an explosive mechanism that pushes the tanks away from the aircraft.
4. Set Fuel Tank Selector Switch to ALL TANKS OFF. This will consume fuel from the aircraft inner fuel tanks.

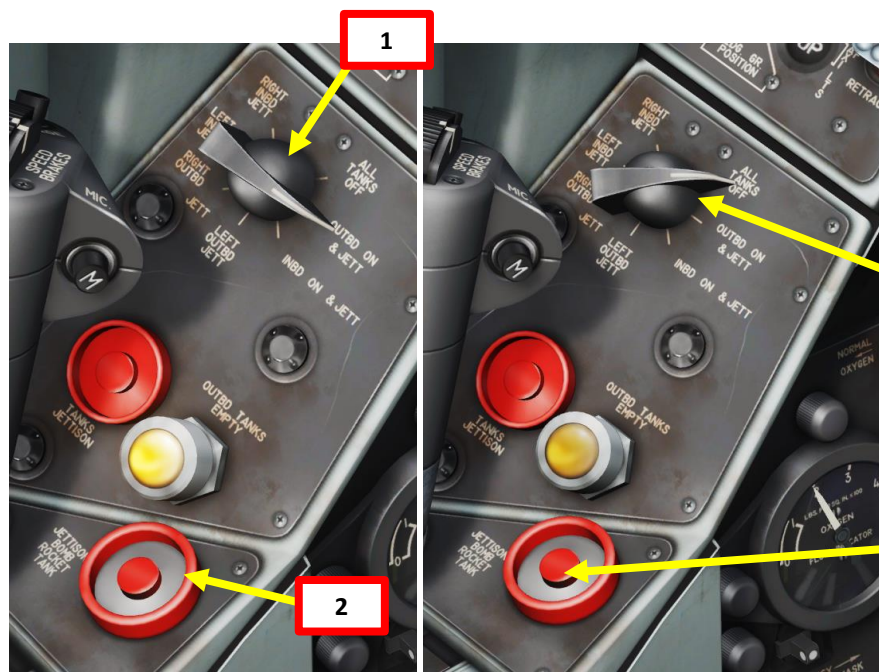

Fuel Tank Selector Switch

- ALL TANKS OFF = SAFETY (Tanks will not drop, fuel is taken from internal tanks)
- OUTBD ON & JETT = Fuel taken from Outboard external tanks, jettison Outboard Tanks Only
- INBD ON & JETT = Fuel taken from Inboard external tanks, jettison Inboard Tanks Only
- Other positions are self-explanatory

Very important note: this switch must be used to choose where the fuel pumps will take fuel from. If you leave the switch to "ALL TANKS OFF", your fuel pumps will use your internal tanks rather than your external tanks if you have them equipped. Trust me: you will need that extra external tank fuel.

Jettison Fuel Tanks Button

Press this to jettison fuel tanks once the tank(s) you want to drop have been selected by the Fuel Tank Selector Switch.

F-86F
SABRE



PART 8 – AIRCRAFT LIMITATIONS



AIRCRAFT LIMITATIONS

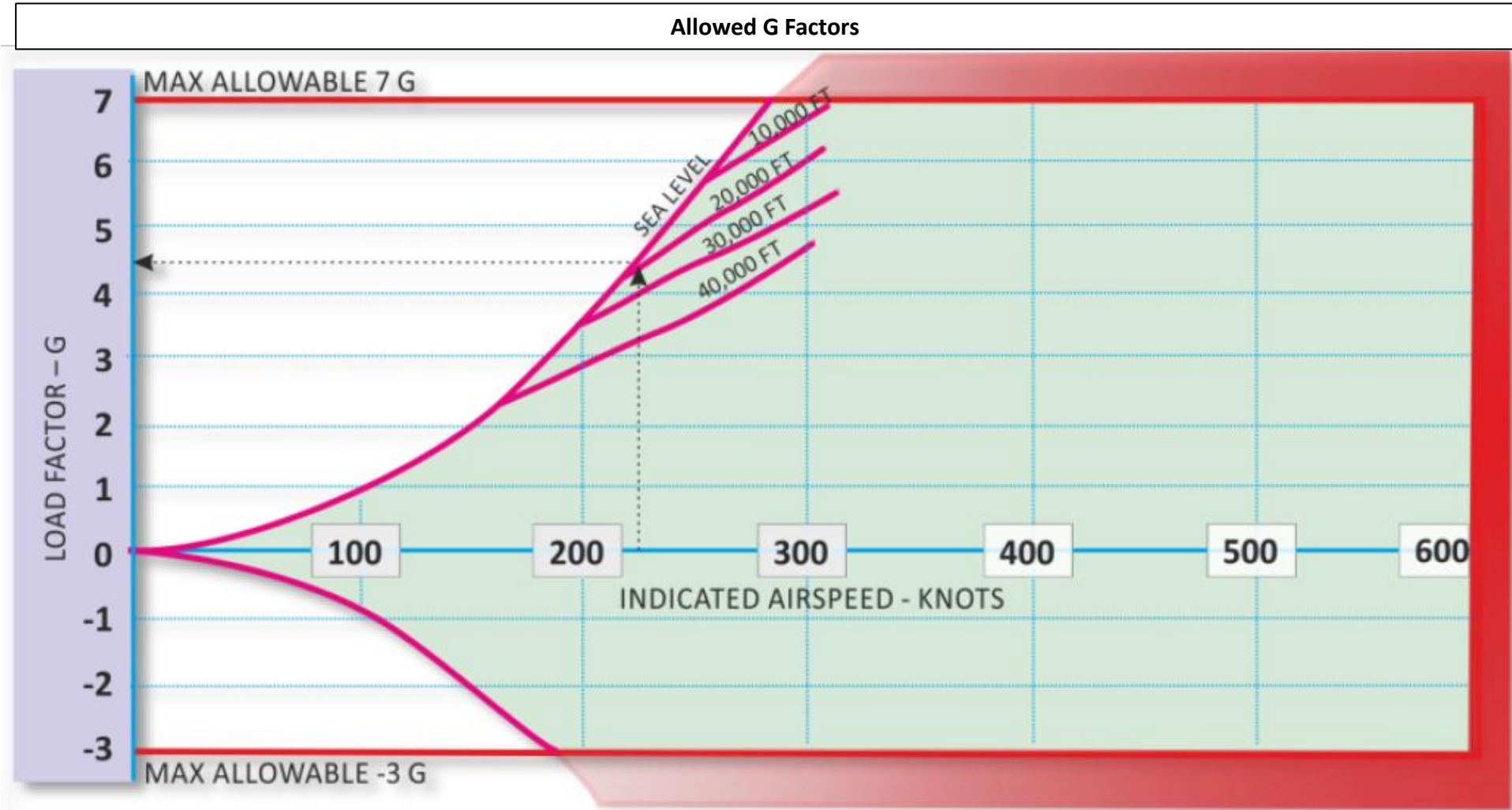

AIRCRAFT LIMITATIONS

Stall Speeds
(Left – Gear and Flaps Up, Right– Gear and Flaps Down)

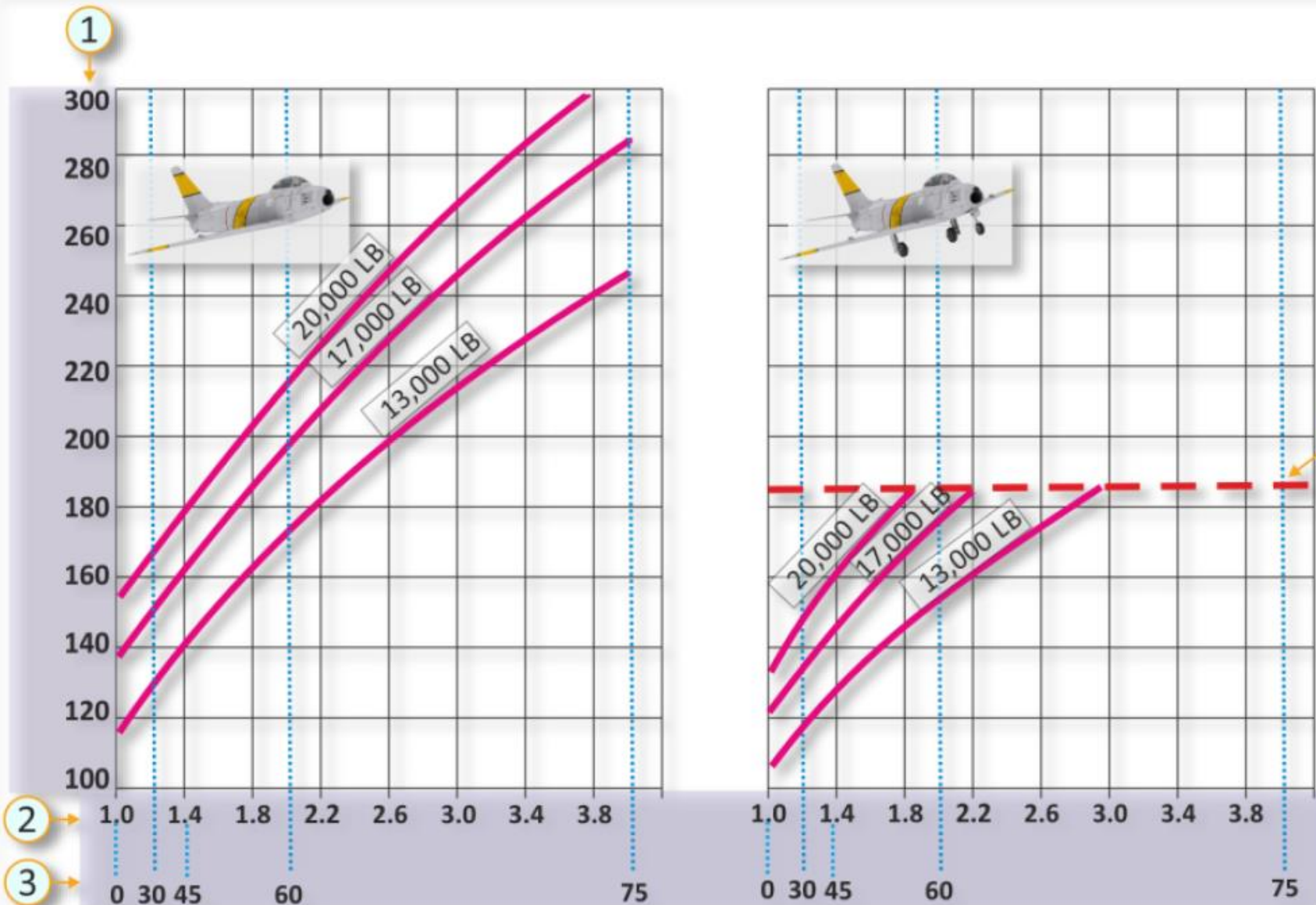

- 1. Indicated air speed (IAS), knots
- 2. G-factor, units
- 3. Roll angle, degrees
- 4. Maximum allowed speed with extended gear and flaps (185 knots)

ROLL RATE

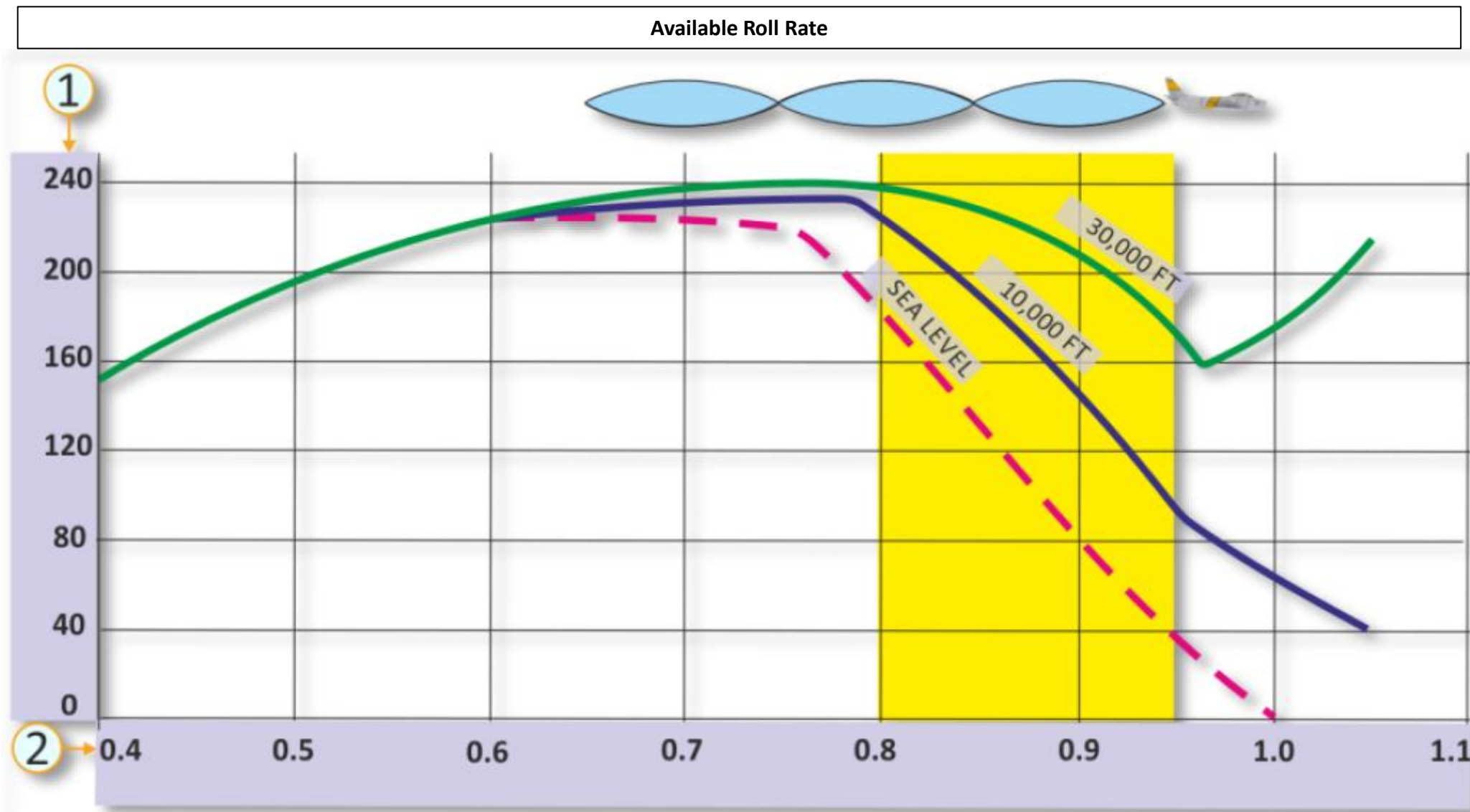

1. Angular roll rate, degrees/s
2. Speed of the airplane, Mach

GLIDING DISTANCE

Gliding distances (nm) from different altitudes (ft) with the engine off

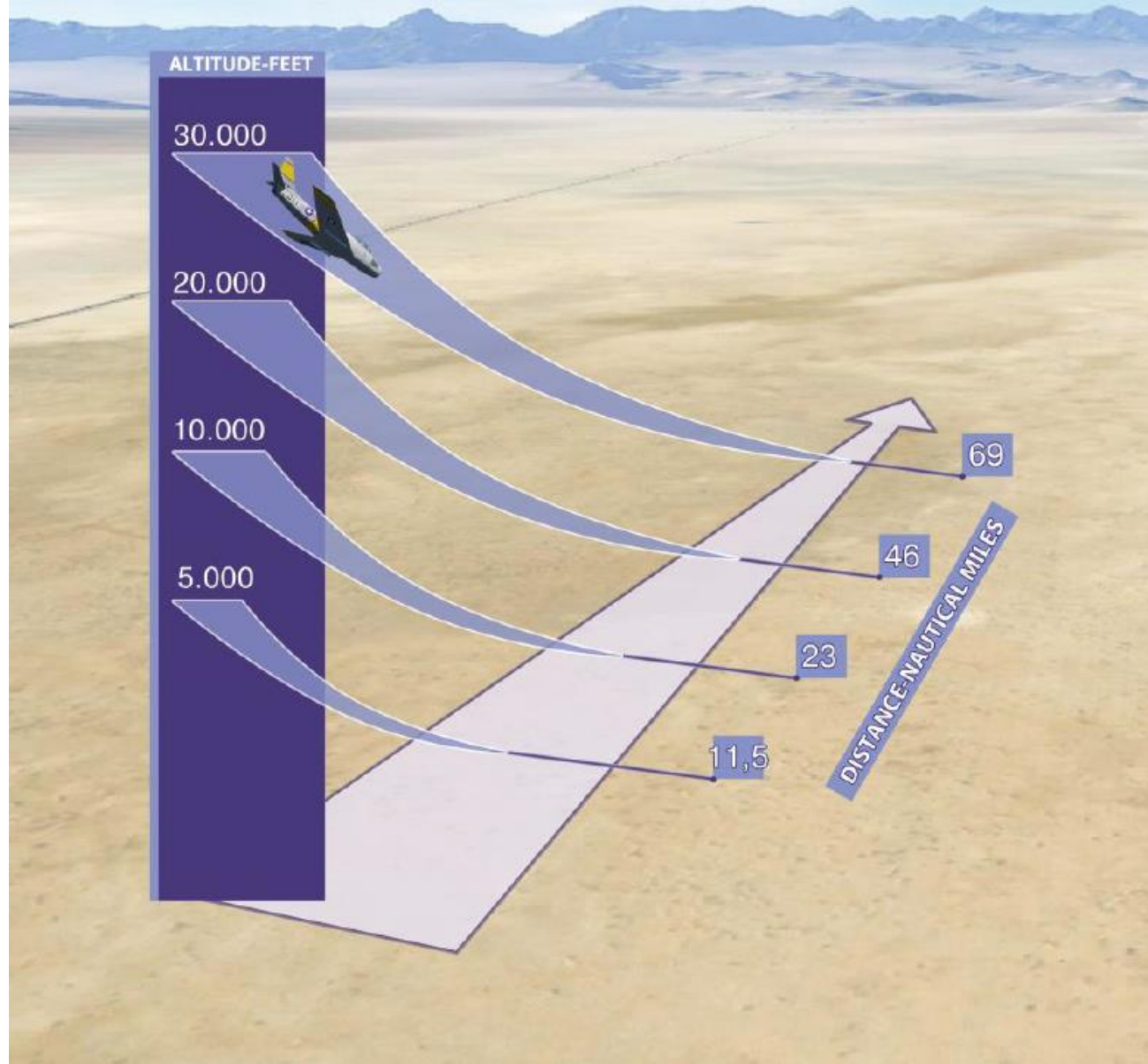

AIRCRAFT LIMITATIONS

airspeed and acceleration limitations

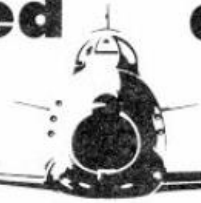

ONLY THE CONFIGURATIONS LISTED
ARE APPROVED FOR FLIGHT.

F-86F-25 AND LATER AIRPLANES

OUTBOARD STATION	INBOARD STATION		INBOARD STATION		OUTBOARD STATION	AIRSPEED LIMITATIONS	G-LIMITS
120 Gal Drop Tank	B37K-1 Bomb rack		B37K-1 Bomb rack		120 Gal Drop Tank	IF BOTH TANKS ARE TYPE I OR III Below 25,000 feet: 500 knots IAS or Mach .90, whichever is lower. Above 25,000 feet: Maximum attainable except avoid buffet regions.	TANKS WITH FUEL +5.0 -2.0 TANKS EMPTY +6.0* -2.0
						IF EITHER TANK IS TYPE II OR IV 500 knots IAS or Mach .90, whichever is lower. No abrupt maneuvers, no continuous rolls, rate of roll limited to 90 degrees per second.	+4.0 -2.0
120 Gal Drop Tank	INBOARD ROCKET STATIONS		INBOARD ROCKET STATIONS		120 Gal Drop Tank	IF BOTH TANKS ARE TYPE I OR III Below 25,000 feet: 500 knots IAS or Mach .90, whichever is lower. Above 25,000 feet: Maximum attainable except avoid buffet regions.	TANKS WITH FUEL +5.0 -2.0 TANKS EMPTY +6.0* -2.0
	MA-2A	MA-2A	MA-2A	MA-2A		IF EITHER TANK IS TYPE II OR IV 500 knots IAS or Mach .90, whichever is lower. No abrupt maneuvers, no continuous rolls, rate of roll limited to 90 degrees per second.	+4.0 -2.0

AIRCRAFT LIMITATIONS

airspeed and acceleration limitations

ONLY THE CONFIGURATIONS LISTED
ARE APPROVED FOR FLIGHT.



F-86F-25 AND LATER AIRPLANES

OUTBOARD STATION	INBOARD STATION		INBOARD STATION		OUTBOARD STATION	AIRSPEED LIMITATIONS	G-LIMITS
120 Gal Drop Tank	MA-3	MA-3	MA-3	MA-3	120 Gal Drop Tank	IF BOTH TANKS ARE TYPE I OR III Below 20,000 feet: Mach .80 Above 20,000 feet: Mach .90	TANKS WITH FUEL +5.0 -2.0 TANKS EMPTY +6.0* -2.0
						IF EITHER TANK IS TYPE II OR IV Below 20,000 feet: Mach .80 Above 20,000 feet: 500 knots IAS or Mach .90, whichever is lower. No abrupt maneuvers, no continuous rolls, rate of roll limited to 90 degrees per second.	+4.0 -2.0
120 Gal Drop Tank	ROCKET STATION	B37K-1 Bomb Rack	MA-2A	MA-2A	120 Gal Drop Tank	IF BOTH TANKS ARE TYPE I OR III Below 25,000 feet: 500 knots IAS or Mach .90, whichever is lower. Above 25,000 feet: Maximum attainable except avoid buffet regions.	TANKS WITH FUEL +5.0 -2.0 TANKS EMPTY +6.0* -2.0
	MA-2A					IF EITHER TANK IS TYPE II OR IV 500 knots IAS or Mach .90, whichever is lower. No abrupt maneuvers, no continuous rolls, rate of roll limited to 90 degrees per second.	+4.0 -2.0

* Positive G-limits for airplanes not changed by T. O. 1F-86F-544 are 5.0 G for straight pull-outs and 3.3 G for rolling pull-outs.

AIRCRAFT LIMITATIONS

AIRSPEED AND ACCELERATION LIMITATIONS

ONLY THE CONFIGURATIONS LISTED
ARE APPROVED FOR FLIGHT



- NOTE**
- The missile rollerons must be pinned to prevent buffet.
 - Positive G-limits for rolling pull-outs are two thirds of limits shown.
 - Negative G-limit for rolling push-down is 1 G.

OUTBOARD STATION	INBOARD STATION	MISSILE STATION	MISSILE STATION	INBOARD STATION	OUTBOARD STATION	AIRSPEED LIMITATIONS	G-LIMITS
		AIM-9B MISSILE	AIM-9B MISSILE*			600 knots IAS or where wing roll is excessive.	+5.0 -2.0
NAA 200 GAL DROP TANK		AIM-9B MISSILE	AIM-9B MISSILE*		NAA 200 GAL DROP TANK	600 knots IAS or where wing roll is excessive. Avoid buffet regions. No continuous rolls.	TANKS WITH FUEL +5.0 -2.0 TANKS EMPTY +5.0 -2.0
NAA 200 GAL DROP TANK	120 GAL DROP TANK	AIM-9B MISSILE	AIM-9B MISSILE*	120 GAL DROP TANK	NAA 200 GAL DROP TANK	IF BOTH 120 GAL TANKS ARE TYPE I OR III Above 25,000 feet: Maximum attainable, except avoid buffet regions. Below 25,000 feet: 500 knots IAS or Mach .90 whichever is lower.	+4.5 -2.0
-----						IF EITHER 120 GAL TANK IS TYPE II OR IV Above 25,000 feet: Mach .85 Below 25,000 feet: Mach .82 No abrupt maneuvers, no continuous rolls, rate of roll limited to 90 degrees per second.	+4.0 -2.0

Figure 5-3A

* or TDU-11/B target rocket

AIRCRAFT OPERATION

Your aircraft can easily go more than 400 kts in level flight, which means that you can very easily black out if you do not pay attention to your speed and accelerometer in turning manoeuvres. Be gentle with the stick.

Speed is very important in combat, but also during landing. Pay attention to the yellow index on the airspeed indicator to know when you can safely deploy your flaps and landing gear. Deploying those at high speeds will make them jam in inconvenient positions, as shown in the picture on the right.

During a normal patrol, you do not need to go full throttle all the time. It needlessly wears the engine down and can create problems with formation flying.

At high Mach numbers (between Mach 0.95 and Mach 1.0), you can lock up your controls easily (especially ailerons). If you want to remain in full of your plane at all times, it is better to fly a little bit slower (Mach 0.7 - 0.8) but keep full authority over your controls. This can prevent unfortunate mid-air collisions with your wingmen (true story).

“Boss, I think I broke something...”

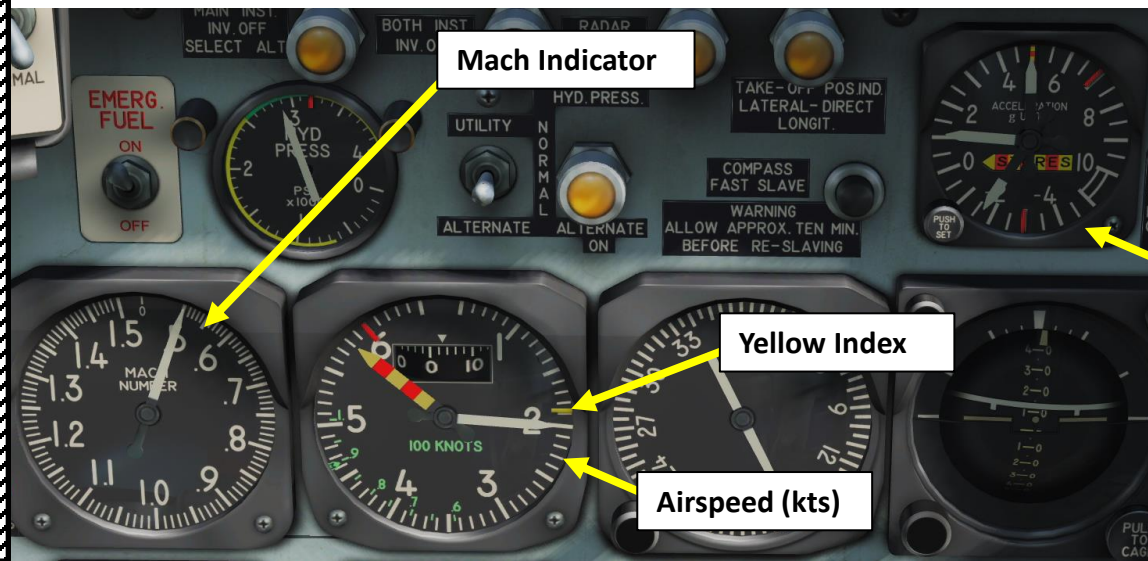

Mach Indicator

Accelerometer (G)

Yellow Index

Airspeed (kts)

AIRCRAFT OPERATION

Typically in World War II fighters, flaps were used to make tighter turns in combat. However, use of flaps during combat is strictly prohibited in the Sabre.

Use of airbrakes can help you turn much tighter if you need to bleed airspeed quickly. They come in very handy in dive bombing and defensive manoeuvres, especially when you have a MiG-15 on your tail that you just can't shake off.

Use airbrakes only when you need to. Bleeding off too much speed in the Sabre can quickly become fatal. Take note that:

1. The MiG-15 outclimbs the F-86
2. The F-86 outperforms the MiG-15 in a dive
3. The F-86 is generally slightly more maneuverable than the MiG-15
4. The F-86 is very vulnerable at low speed

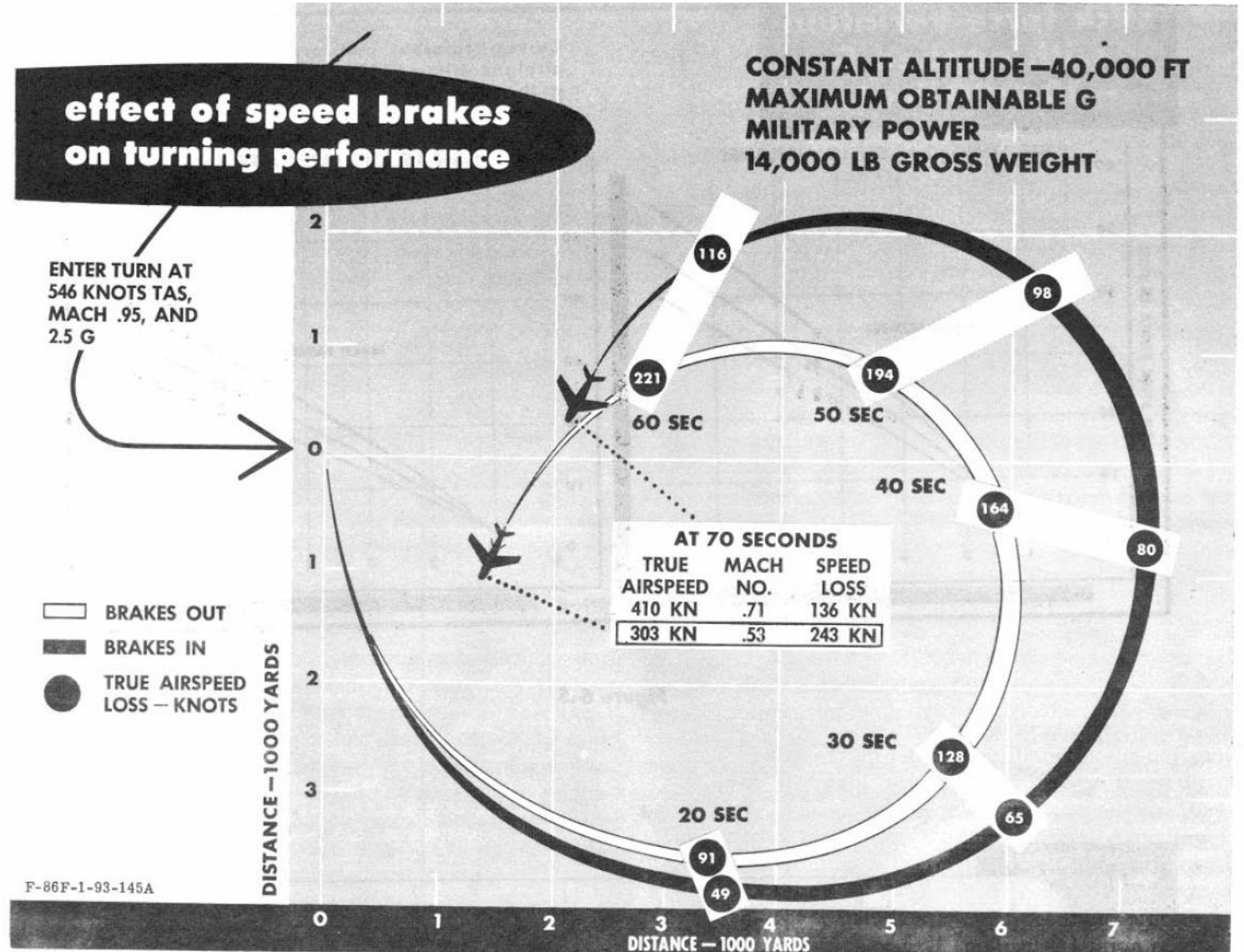

EMERGENCY LANDING GEAR DEPLOYMENT

In the case of a landing gear failure, here is the procedure for emergency landing gear deployment.

1. Reduce airspeed below 175 knots. Failing to slow down means that airloads may hold fairing doors closed.
2. Set Landing Gear Handle – DOWN.
3. Pull and hold Emergency Landing Gear Release Handle to lower landing gear.
4. Yaw airplane with rudder pedals to lock main gear if necessary.
5. Check for safe gear indication on the Landing Gear Position Indicators, then release Emergency Landing Gear handle.



Emergency Landing Gear Handle 3



2

EMERGENCY LANDING GEAR RETRACTION

In the real F-86, the emergency gear retraction system was designed to allow the landing gear to be retracted during maintenance as well as during engine failure on takeoff when the engine failed at rotation speed on a short runway and there was not enough room to stop. The **early ejection seats were not survivable at ground level**. Therefore, the emergency gear retraction system was implemented to **give pilots a chance if they lost an engine on takeoff**.

When the emergency gear retraction button was pressed, it would cause the landing gear to smash through the gear doors (not simulated). This was because the emergency gear retraction system had its own complete hydraulic line system and did not send any pressure to the gear doors to open them.

In the simulation, the system does not have its own hydraulic line. Therefore, before the emergency gear retraction button is pressed, the landing gear control handle must be in the up position to allow the gear doors to open. If the emergency gear retraction button is pressed with the landing gear control handle in the down position, the gear will not retract.

Landing Gear Emergency
Up Button

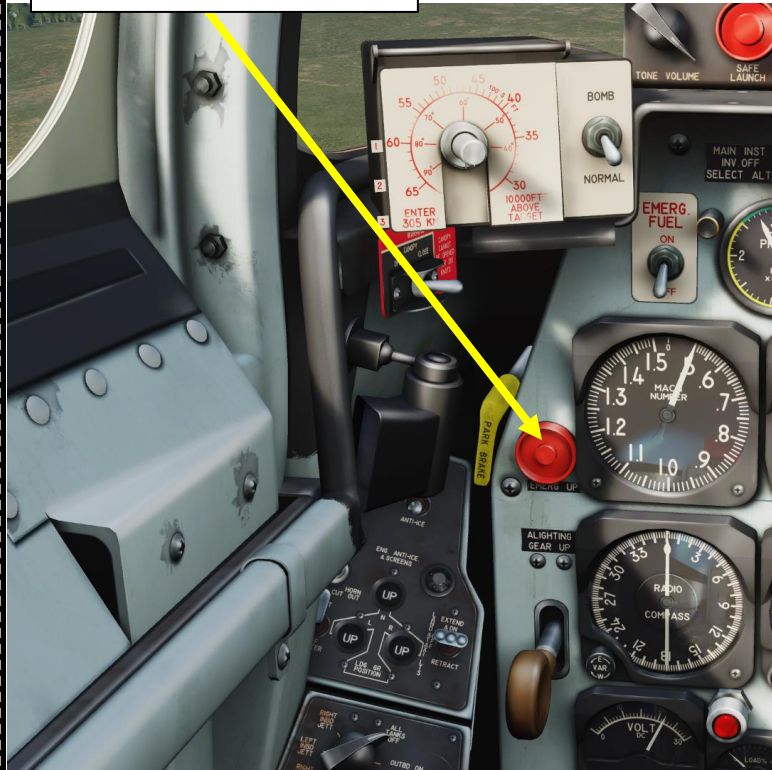



ARMAMENT OVERVIEW

- 6 x 0.50 cal Browning M3 Machineguns (1800 rounds total)
 - 300 rounds for each guns
- 2 x GAR-8 Infrared Seeking Missiles (AIM-9 prototypes)
- 2 x M64 500 lbs Bombs
- 2 x M117 750 lbs Bombs
- 16 x HVAR (High Velocity Aircraft Rocket) 5-in. Rockets

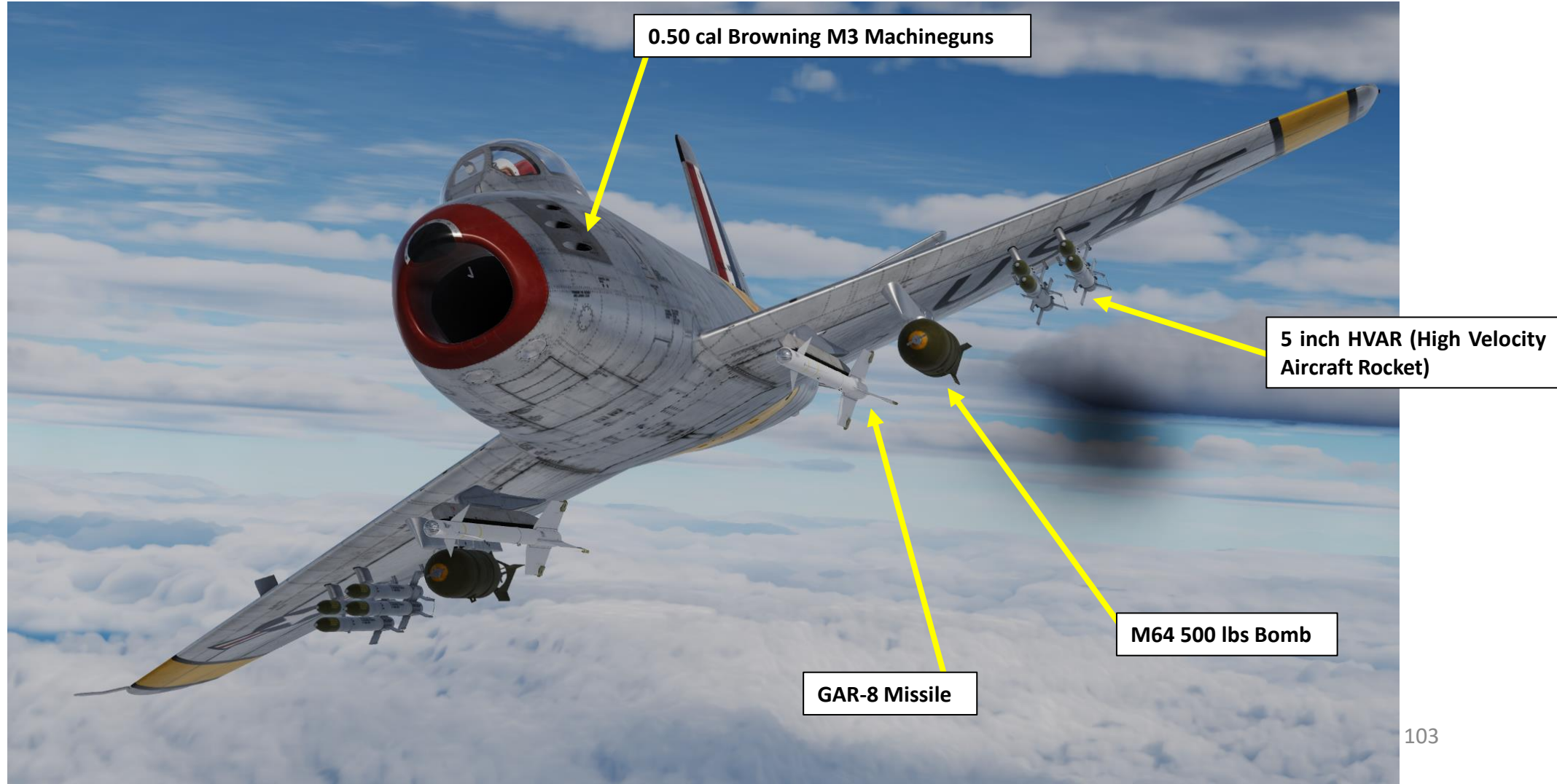

A-4 GYRO GUNSIGHT

The A-4 gyro sight is used for aiming when firing guns, bombing, launching rockets, or firing missiles. The sight includes a ballistics computer (resolver) designed to facilitate aiming (although aiming can also be done manually). A gyro built into the sight is used to determine the aircraft's turning rate which is then fed into the computer.

In addition to the ballistics computer, the sight automatically connects to one of the armament subsystems depending on the type of weapon selected on the sight selector unit. The sight reticle image consists of a center dot inside a circle of ten equally spaced diamond-shaped dots (or diamonds). The image of these diamonds is projected onto the sight's reflector glass, and can move across the glass depending on the weapon used and the sight operation mode.

Throttle Twist Grip (Gunsight Distance to Target Selector)

A twist grip is incorporated into the throttle which allows manual target ranging. This is useful if the gun sight's automatic function fails or if target engagement occurs at altitudes below 6,000 feet where radar ranging becomes erratic because of ground effects.

The manual range control covers a span from 1,200 feet to 2,700 feet.

- Clockwise rotation of the twist grip increases reticle diameter (reduces the range)
- Counterclockwise rotation decreases reticle diameter (increases the range).



Wingspan of a MiG-15: 32 ft (10 m)
(Value to enter in gunsight wingspan)



A-4 Gyro Sight Reticle

Reflector Glass

Bombing Altimeter (ft)

Target Range (ft)

Mechanical Sight Cage/Uncage Lever
RIGHT = UNCAGED (UNLOCKED)
LEFT = CAGED (LOCKED)



Gunsight Target Wingspan Setting Selector (ft)

Gunsight Dimmer

A-4 GYRO GUNSIGHT

The **Mechanical Sight Cage/Uncage Lever** has two positions: LEFT for CAGED mode, and RIGHT for UNCAGED mode.

- **UNCAGE position** allows normal, automatic operation of the sight.
- **CAGE position** mechanically stabilizes the sight gyro. This position should be used for ground attacks or in the case of sight gyro or computer failure. Even with the gyro is caged, the reticle size can be adjusted manually based on the target's wing span.

The **Gunsight Electrical Cage/Uncage Button**, on the other hand, accomplishes a similar function to the Mechanical Sight Cage/Uncage Lever, however it allows the pilot to keep hands on the controls when manoeuvring.



Gunsight Electrical Cage/Uncage Button

The sight is caged electrically when the caging button on the throttle is held depressed. This results in the sight reticle image being stabilized. Image stabilization is necessary to limit gyro deflection as the result of maneuvering on the initial approach to the target. Unlike the sight mechanical caging lever, the button on the throttle allows the pilot to keep hands on the controls which is especially important in a maneuvering battle. This also makes the sight combat-ready (it starts working together with the computer) immediately after the button is released.

A-4 Gyro Sight Reticle Uncaged

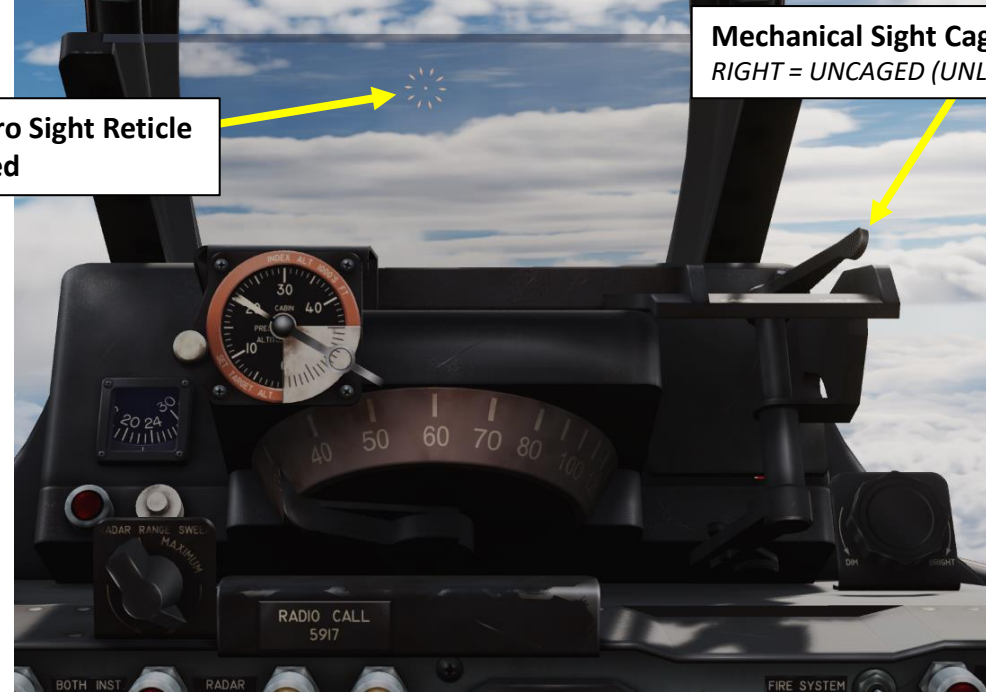

Mechanical Sight Cage/Uncage Lever
RIGHT = UNCAGED (UNLOCKED)

A-4 Gyro Sight Reticle Caged

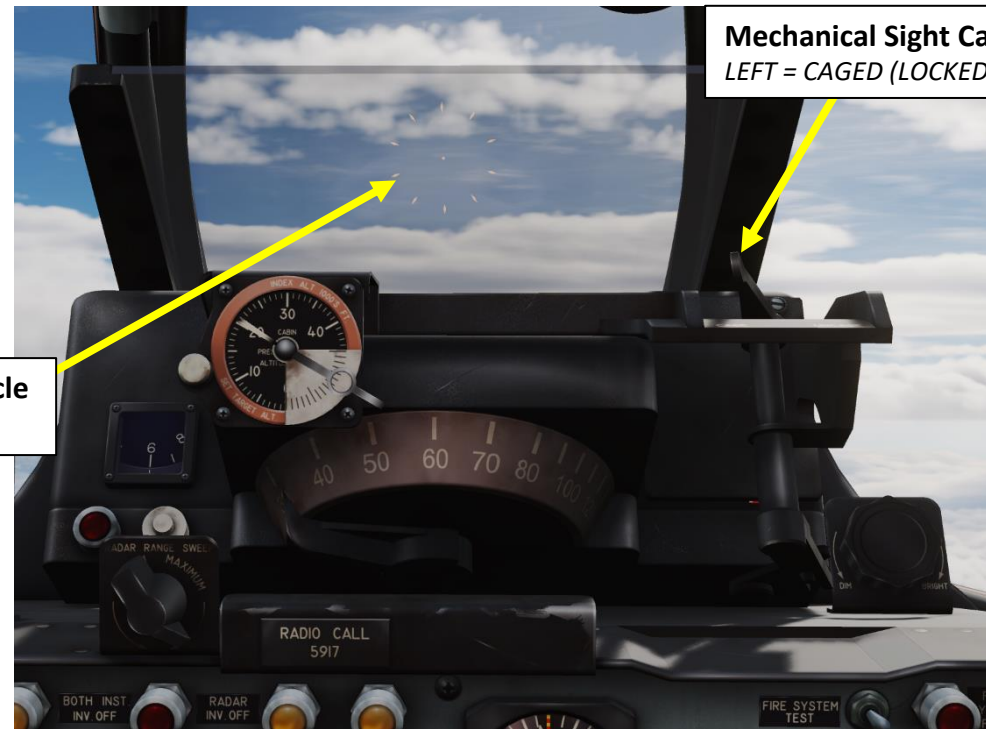

Mechanical Sight Cage/Uncage Lever
LEFT = CAGED (LOCKED)

A-4 GYRO GUNSIGHT

The sight selector unit is used to connect the sight to one of the weapon subsystems (rockets, guns, or bombs), to set the rocket sight angle, and to select the air target speed.

UPWIND scale – used to enter headwind speed or receding target speed

DOWNWIND scale – used to enter tailwind speed or approaching target speed



Bomb Target Wind Correction Setting (kts)

Bomb Drop Speed HI/LOW Selector

Gunsight Function Selector
Rocket/Gun/Bomb

Rocket Depression Angle Selector (deg)

Gunsight Filament Selector

Weapon Selector

- **OFF:** all functions supplying gunsight (gyro and backlight), camera, radar, gun firing, and missile launching are disabled
- **Sight Camera & Radar:** gunsight and camera operate in normal mode while gun firing and missile launching circuits are disabled
- **Guns:** gunsight and camera operate in normal mode, gun firing circuits are enabled, and missile launching circuits are disabled
- **Missile:** gunsight and camera operate in normal mode, missile launching circuits are enabled, and gun firing circuits are disabled

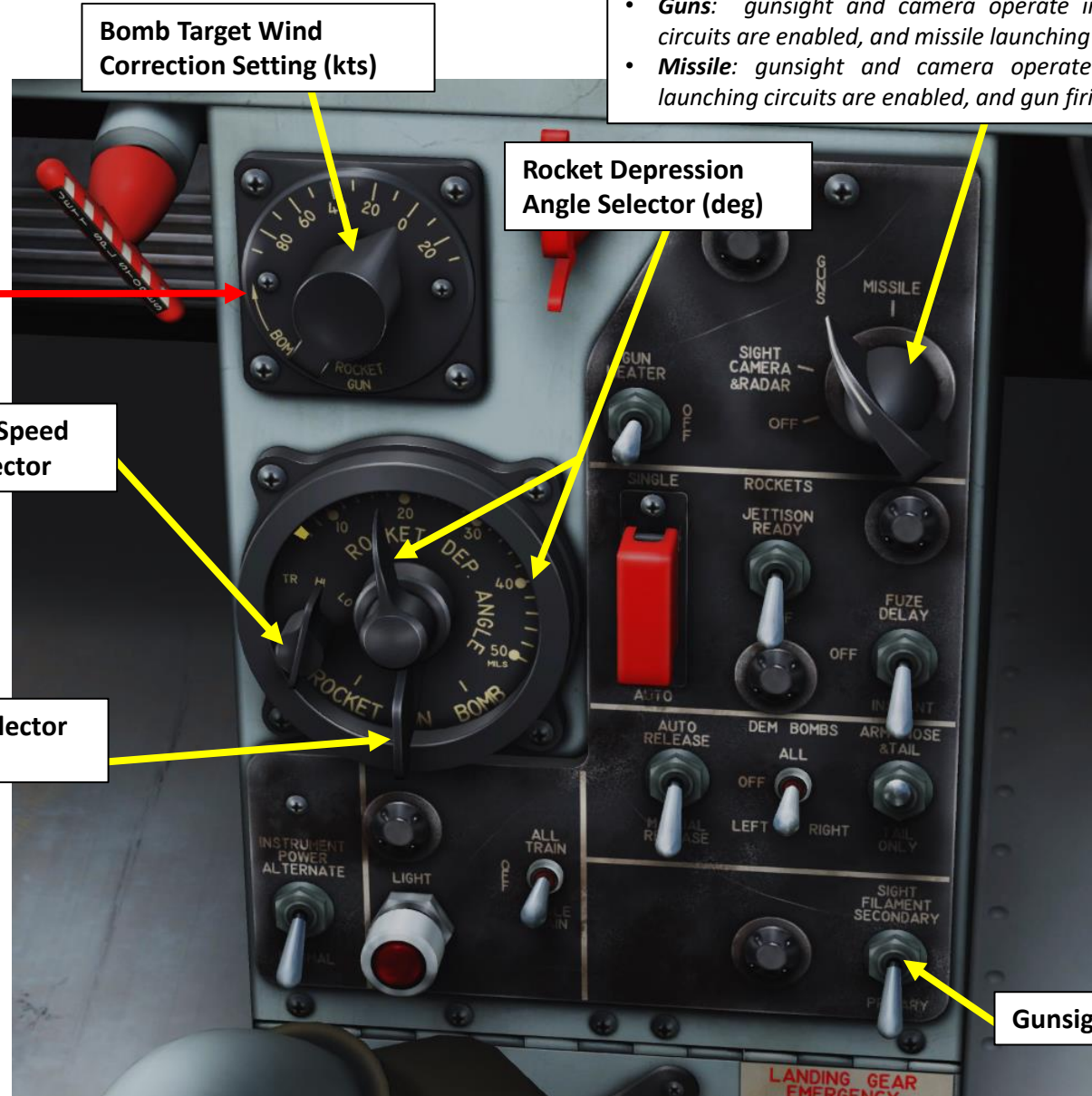

A-4 GYRO GUNSIGHT

Shooting at air targets

Point/Position 1: At entry to the attack, the gyro is caged with the pilot observing the target through the center dot of the sight. "Range" is set to 2,500 ft, for example.

Point/Position 2: The pilot has uncaged the sight's gyro and is turning the aircraft to keep the target in the field of vision. Since the aircraft's angular velocity is now a factor, the gyro precession causes the sight reticle image to lag behind the target. For the set range of 2,500 ft, the sight's computer has applied a maximum correction, forcing the sight image nearly outside the field of vision.

Point/Position 3: The pilot has closed in on the target and, hence, has reduced the range on the rheostat to the minimum. This results in the spacing between the diamond-shaped dots to be larger and also causes the sight reticle image to move closer to the center of the sight due to the decreased angular correction. Therefore, the pilot has an easier time keeping the target inside the circle of diamond-shaped dots. When the target is located precisely in the center of the circle, the aiming angle (the angle between the aircraft's axis and the gyro axis pointing to the target) has been established.

Point/Position 4: Any projectiles (bullets) that have been fired impact the target.

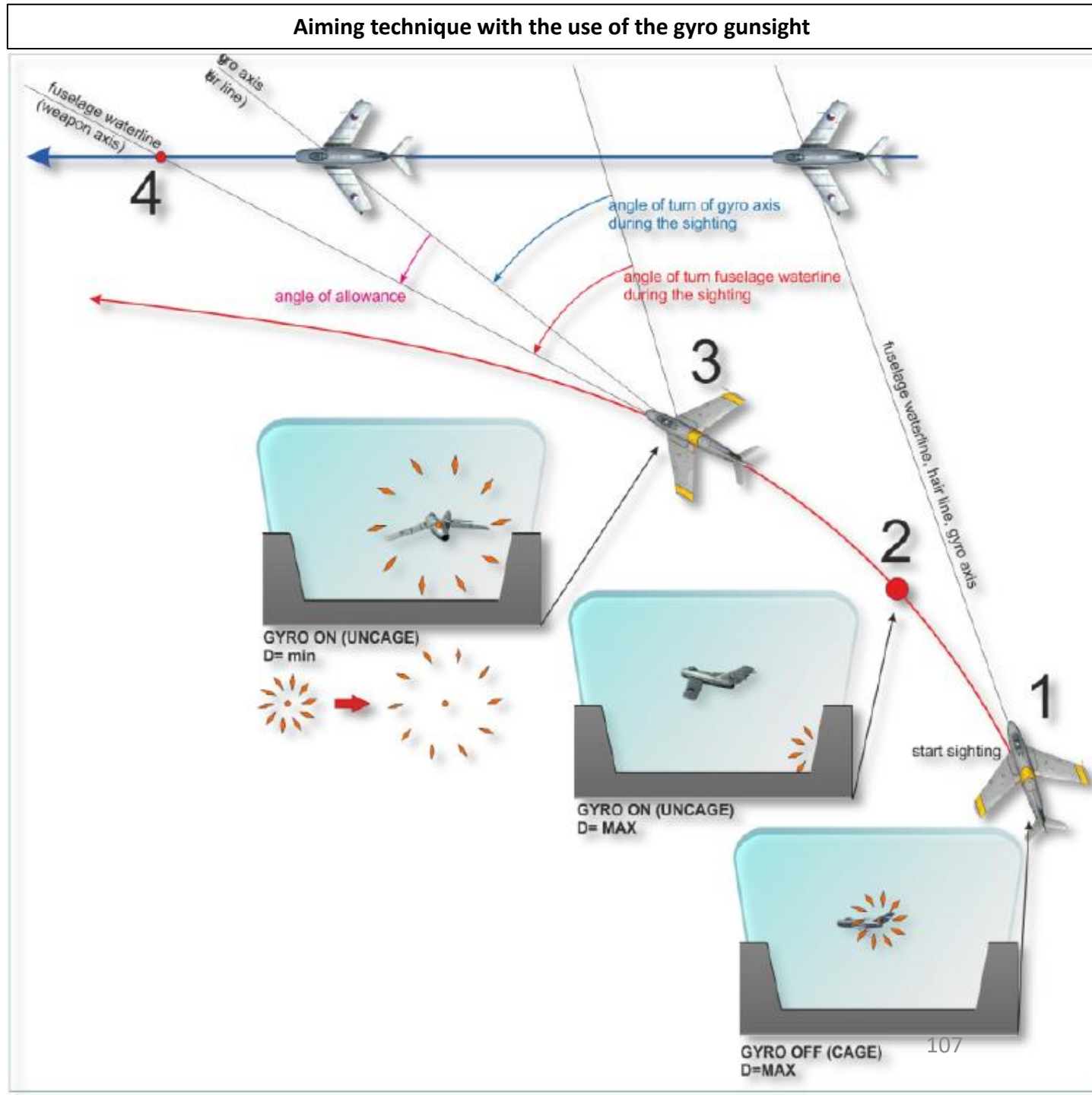

AN/APG-30 RADAR RANGING UNIT

The Sabre is equipped with the **AN/APG-30 radar ranging unit**. Approximate range of the AN/APG-30 radar ranging unit is from 450 to 9,000 feet. The AN/APG-30 automatically locks on and tracks the target, indicating its range in thousands of feet.



AN/APG-30 RADAR/FIRE CONTROL SYSTEM

Radar Bay

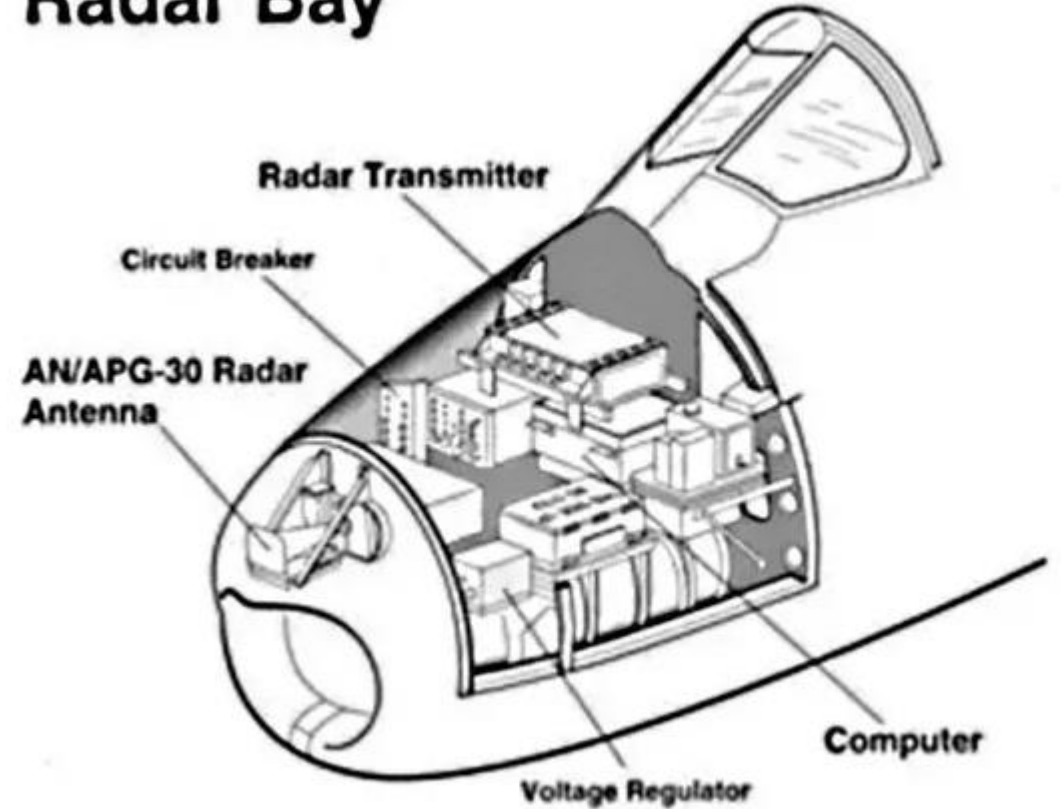

F-86F FIGHTER-BOMBER JET AIRCRAFT

AN/APG-30 RADAR RANGING UNIT

The radar equipment is operative when the **Weapon Selector** is set to any position other than OFF. When operating the Radar Ranging Unit with the A-4 Sight, the **twist grip** on the throttle should be turned fully counter-clockwise to allow a maximum radar detection range. Current max radar range is 1600 ft. Radar target light becomes red once a target is spotted; it might suffer interference under an altitude of 6000 ft because of ground clutter.



Weapon Selector

- **OFF:** all circuits supplying gunsight (gyro and backlight), camera, radar, gun firing, and missile launching are disabled
- **Sight Camera & Radar:** gunsight and camera operate in normal mode while gun firing and missile launching circuits are disabled
- **Guns:** gunsight and camera operate in normal mode, gun firing circuits are enabled, and missile launching circuits are disabled
- **Missile:** gunsight and camera operate in normal mode, missile launching circuits are enabled, and gun firing circuits are disabled

Radar Target Indicator Light

Illuminates when the radar ranging equipment has locked on to the target and has started tracking it.

Target Range Computed by Radar (ft)

A-4 Gyro Sight Reticle

Throttle Twist Grip

Radar Range Sweep Setting Rheostat

used to change the radar output power, thus decreasing or increasing target detection range. **MAXIMUM** is the normal position at the start of an attack. It is recommended that the power be reduced during low altitude operations to prevent the radar from locking on to the ground or ground objects.

Main Radar (single-phase) Inverter Failure Light

M3 BROWNING 0.50 CAL MACHINEGUNS

- Note 1: Guns are charged and unloaded on the ground before and after flight. If gun stoppage occurs in the air, it can only be cleared manually on the ground via a ground crew repair command.
 - Note 2: In the real F-86, to avoid muzzle contamination after charging, the guns are capped with rubber plugs that are blown off when the guns are fired.
1. Set weapon selector to "GUNS". Do it 10 minutes in advance to let the A-4 Gunsight System warm up.
 2. Set the Gun Selector to "ALL GUNS".
 3. Set Target Wingspan to about 30 ft (wingspan of a MiG-15)
 4. Uncage Mechanical Sight by setting the Mechanical Sight Cage/Uncage Lever RIGHT (Uncaged) before engaging air target.



M3 BROWNING 0.50 CAL MACHINEGUNS

- Current max radar range is 1600 ft. Radar light will become red once a target is spotted and it might suffer interference under an altitude of 6000 ft because of ground clutter. Continuous light means continuous radar tracking, while flickering light means that radar is spotting something but not actively tracking it.
- Hold the Electrical Caging switch for a few seconds (gunsight will stop moving) and release it (gunsight will begin tracking). Target range on the range dial will start tracking the target's range.



Gunsight Electrical
Cage/Uncage Button

6

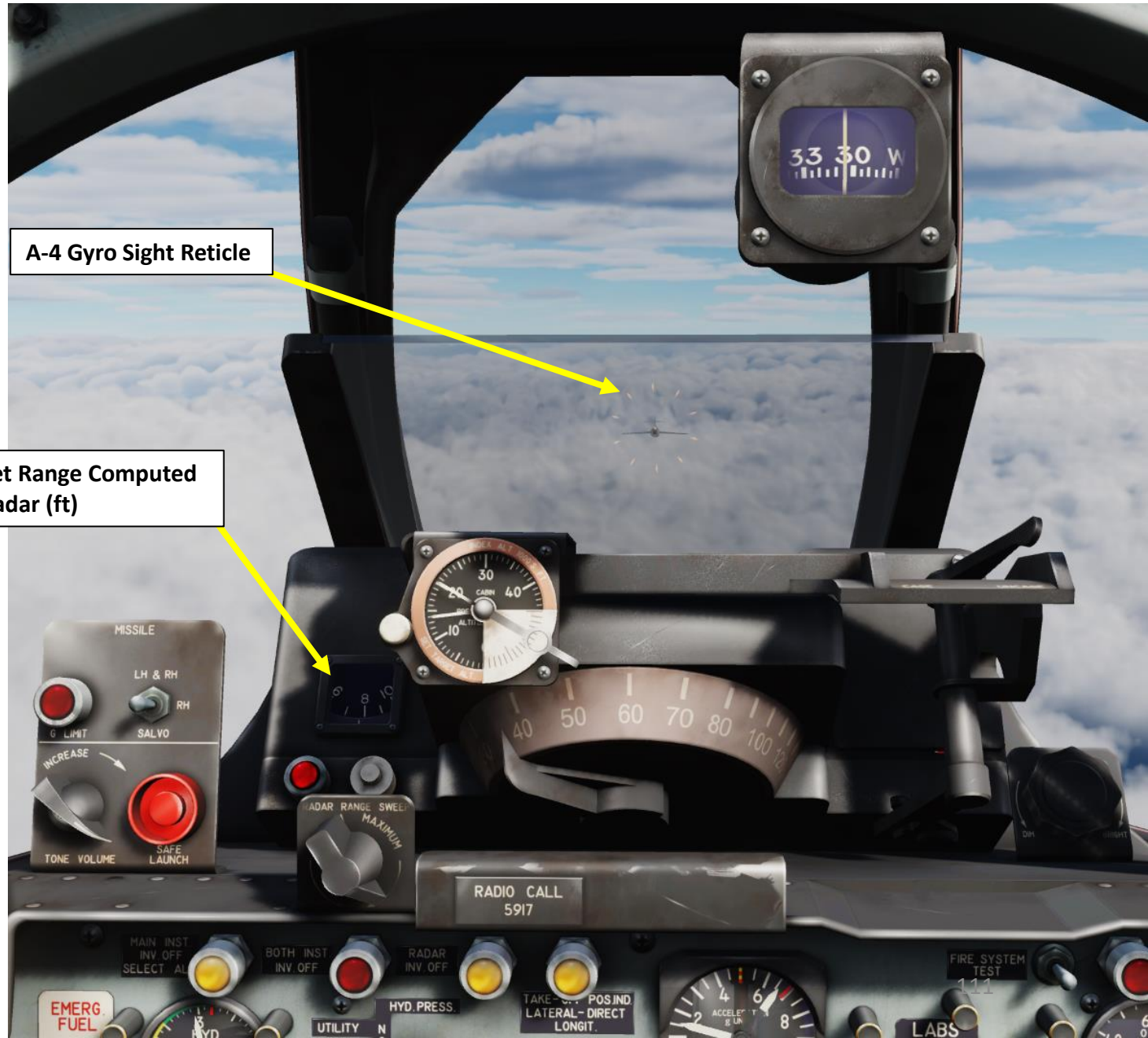

A-4 Gyro Sight Reticle

Target Range Computed
by Radar (ft)

M3 BROWNING 0.50 CAL MACHINEGUNS

7. When target's wingspan fits the gunsight, fire on the target by squeezing the Gun Fire trigger (Second Detent, "Spacebar" binding).
8. Containers in the lower portion of the fuselage retain ejected cases; empty cartridges do not leave the aircraft during firing.

7 Gun Trigger
(Second Detent)



GAR-8 INFRARED SEEKER MISSILE (AIM-9 PROTOTYPE)

1. Set weapon selector to “MISSILE”. Do it 10 minutes in advance to let the A-4 Gunsight System warm up.
2. When approaching the target area, move the missile safe switch to ARM and the missile control switch to LH & RH (Single missile is fired, which is the left missile) or RH (Single missile is fired, which is the right missile).
 - Note: SALVO mode fires both missiles, but I do not necessarily recommend it.
3. Turn the Missile Volume Control Knob so that background signal (low pitch missile growling sound) is at an adequate audio.
4. Cage Mechanical Sight by setting the Mechanical Sight Cage/Uncage Lever Left (Caged) before engaging air target.



GAR-8 INFRARED SEEKER MISSILE (AIM-9 PROTOTYPE)

5. Use the A-4 sight to track the target.
6. Listen for the missile “ready” tone in the headset (high-pitch growl signal indicates that the missile has detected an infrared target). Care must be taken to ensure the missile has locked on to the intended target and not a background heat signal. Readjust the “ready” signal as desired.
 - There are situations where the missile can distinguish the target from background infrared sources but the lock may not be detectable to the pilot through the “ready” tone. When the pilot fires under these conditions, they must make sure the target is within the missile’s firing envelope.
 - The missile can detect targets that may be outside of its effective range.
 - If the target is within range but no “ready” tone is heard and there is concern about missile malfunction, move the missile control switch to RH if LH & RH was previously selected.
7. Make sure the G-Limit Light is not illuminated; this light indicates missile G limits are exceeded.



A-4 Gyro Sight Reticle

Missile Launch Parameter (G-Limit) Exceedance Light
(On when aircraft exceeds G limits for missile launch)



GAR-8 INFRARED SEEKER MISSILE (AIM-9 PROTOTYPE)

8. Fire missile by squeezing the Gun Fire trigger (Second Detent, “Spacebar” binding).
9. When the engagement is over, return the gun-missile selector and missile control switches to their OFF positions.

8 Gun Trigger
(Second Detent)



GAR-8 INFRARED SEEKER MISSILE (AIM-9 PROTOTYPE)



HVAR 5-INCH ROCKETS

1. Set Weapon Mode to "SIGHT CAMERA & RADAR"
2. Flip the Rocket Mode safety guard
3. Set Rocket Mode to either SINGLE (UP) or AUTO (DOWN)
4. Set Intervalometer to 1 if no drop tanks are equipped. If drop tanks are equipped, set Intervalometer to 9.
 - First rocket to be fired is set with the rocket intervalometer
5. Uncage Mechanical Sight by setting the Mechanical Sight Cage/Uncage Lever RIGHT (Uncaged).
6. On Sight Selector Unit, place Sight Function Selector to ROCKET.
7. On Sight Selector Unit, set rocket drop correction using the Rocket Depression Angle Setting control.
 - For a firing range between 5,000 to 6,000 ft and a dive angle up to 20°, set 35–40 mils
 - For a dive angle of 30 to 40°, set 25–35 mils
8. Set Rocket Jettison Switch – OFF (DOWN)
9. Set Rocket Fuze Delay Setting – INSTANT (DOWN)

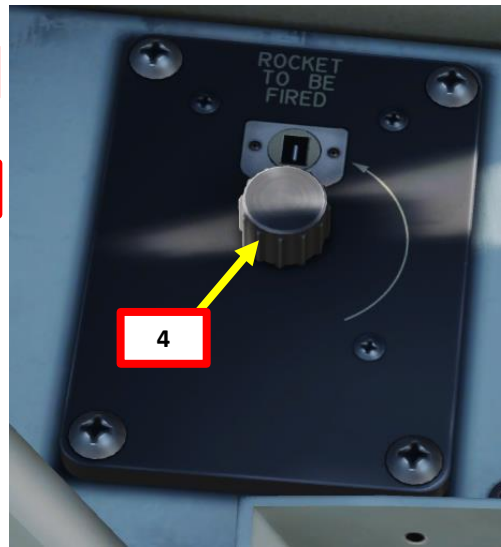
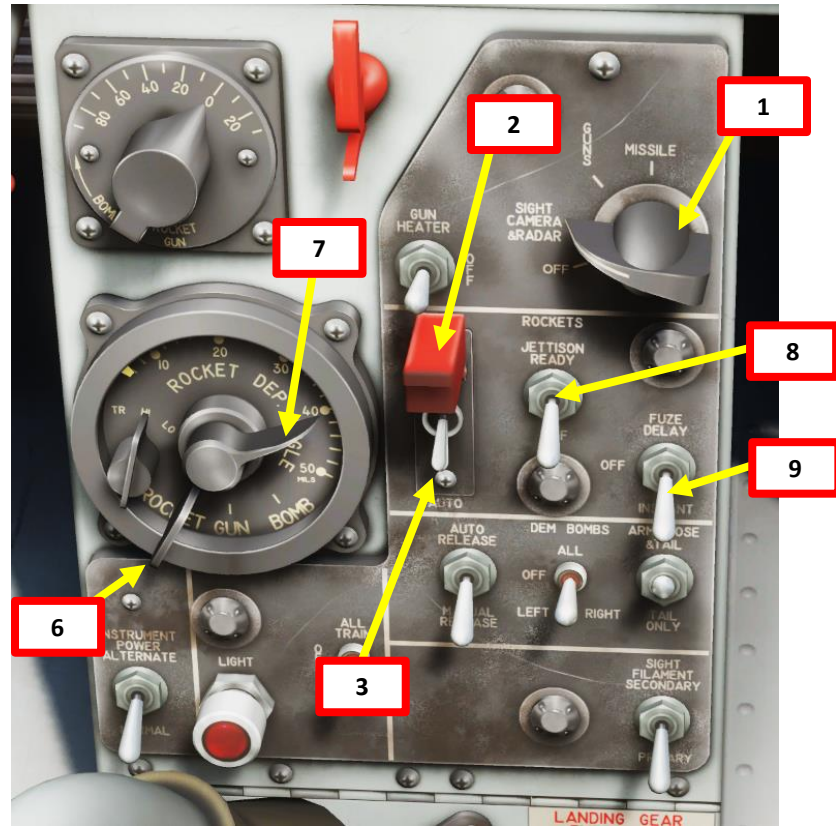

HVAR 5-INCH ROCKETS

10. Before dive entry, depress and hold the sight electrical caging button to stabilize reticle image.
11. Perform diving attack on target from 6000 ft and a dive angle of 20 deg
12. While maintaining the attack approach, keep the sight reticle center dot on the target and release the sight electrical caging button to initiate resolver operation (uncage the sight gyro).
13. Continue to track the target smoothly for approximately 3 seconds without slipping or skidding.
14. Fire your rockets by pressing the "WEAPON RELEASE" Button (RALT+SPACE).

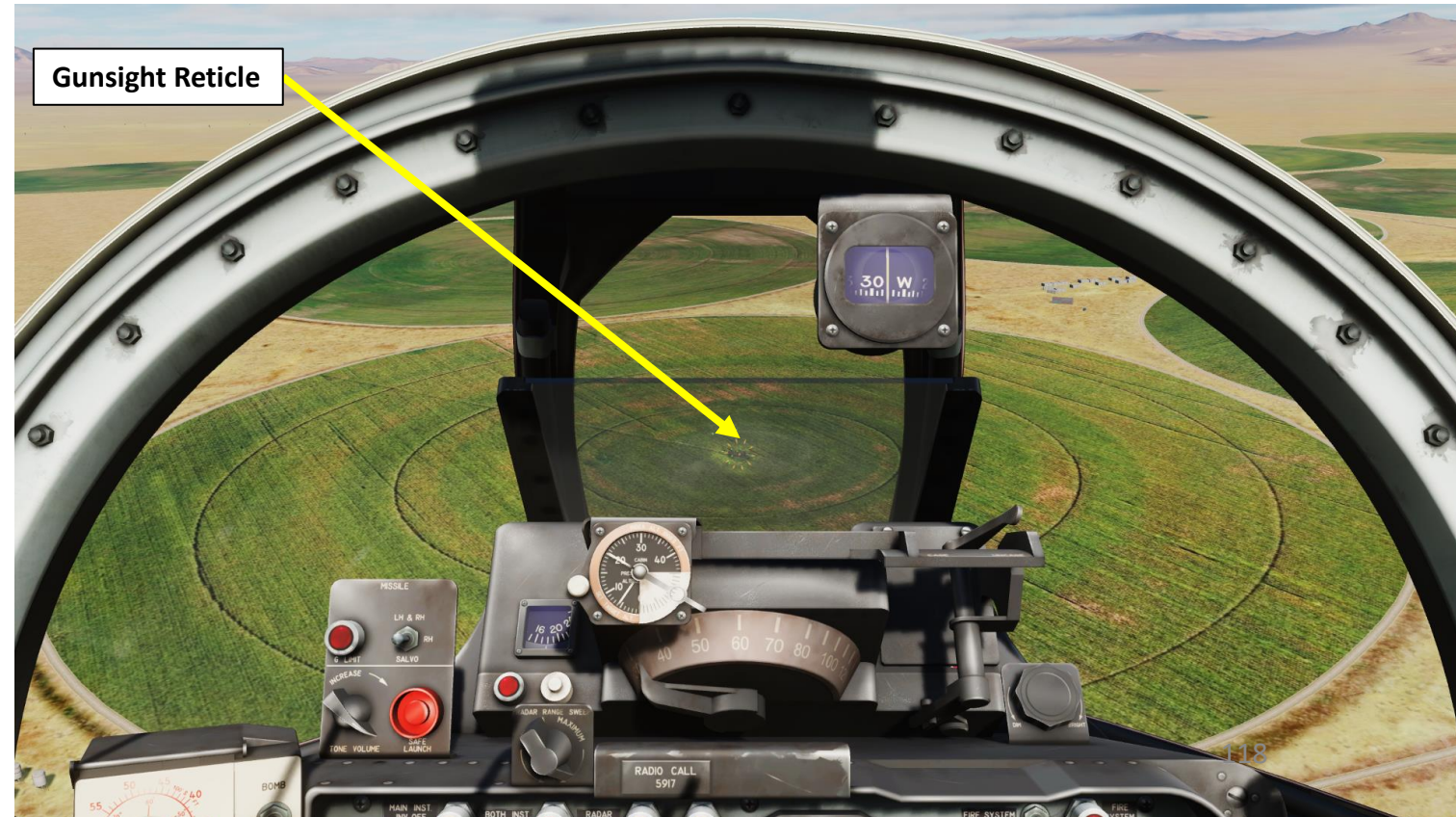
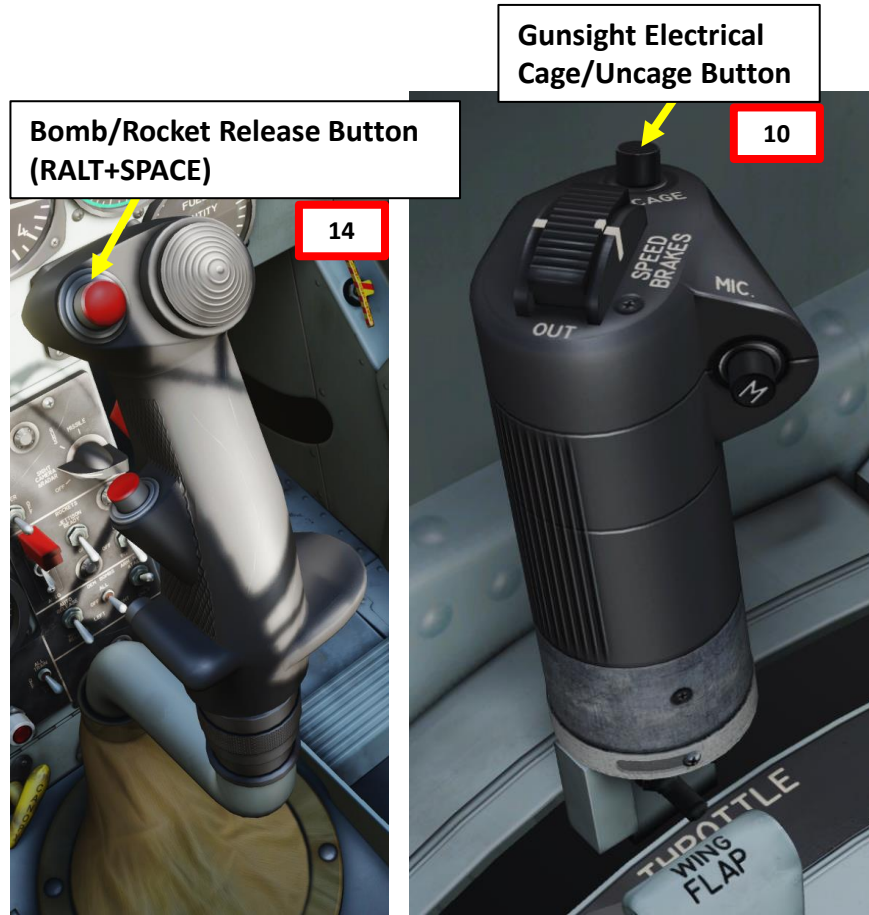

HVAR 5-INCH ROCKETS



MANUAL DIVE BOMBING – M64 BOMBS (500 LBS)

1. Set Weapon Mode to "SIGHT CAMERA & RADAR"
2. Set Fuze Mode to "ARM NOSE & TAIL"
3. Set Gunsight Mode to "BOMB"
4. Set Release Mode to "MANUAL"
5. Select desired Bomb Loadout to Drop (ALL/LEFT/RIGHT)
6. Uncage Mechanical Sight by setting the Mechanical Sight Cage/Uncage Lever RIGHT (Uncaged).



MANUAL DIVE BOMBING – M64 BOMBS (500 LBS)

7. Deploy Airbrakes and dive for your target
8. While maintaining the attack approach, keep the reticle center dot on target and then release the electrical caging button to uncage the sight.
9. The center reticle dot should be kept on the target until the dot disappears at the calculated release point.
10. Drop your ordnance by pressing the “WEAPON RELEASE” Button (RALT+SPACE).

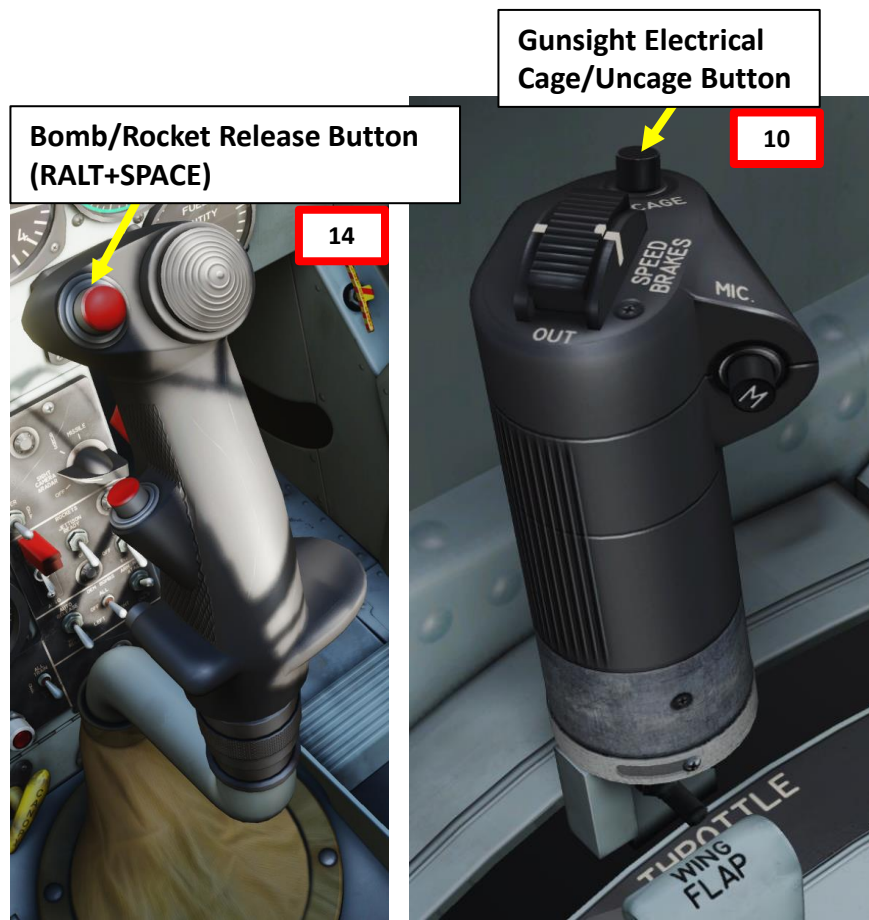

MANUAL DIVE BOMBING – M64 BOMBS (500 LBS)



AUTOMATIC DIVE BOMBING – M64 BOMBS (500 LBS)

1. Set Weapon Mode to "SIGHT CAMERA & RADAR"
2. Set Fuze Mode to "ARM NOSE & TAIL"
3. Set Gunsight Mode to "BOMB"
4. Set Release Mode to "MANUAL"
5. Select desired Bomb Loadout to Drop (ALL/LEFT/RIGHT)
6. Uncage Mechanical Sight by setting the Mechanical Sight Cage/Uncage Lever RIGHT (Uncaged).

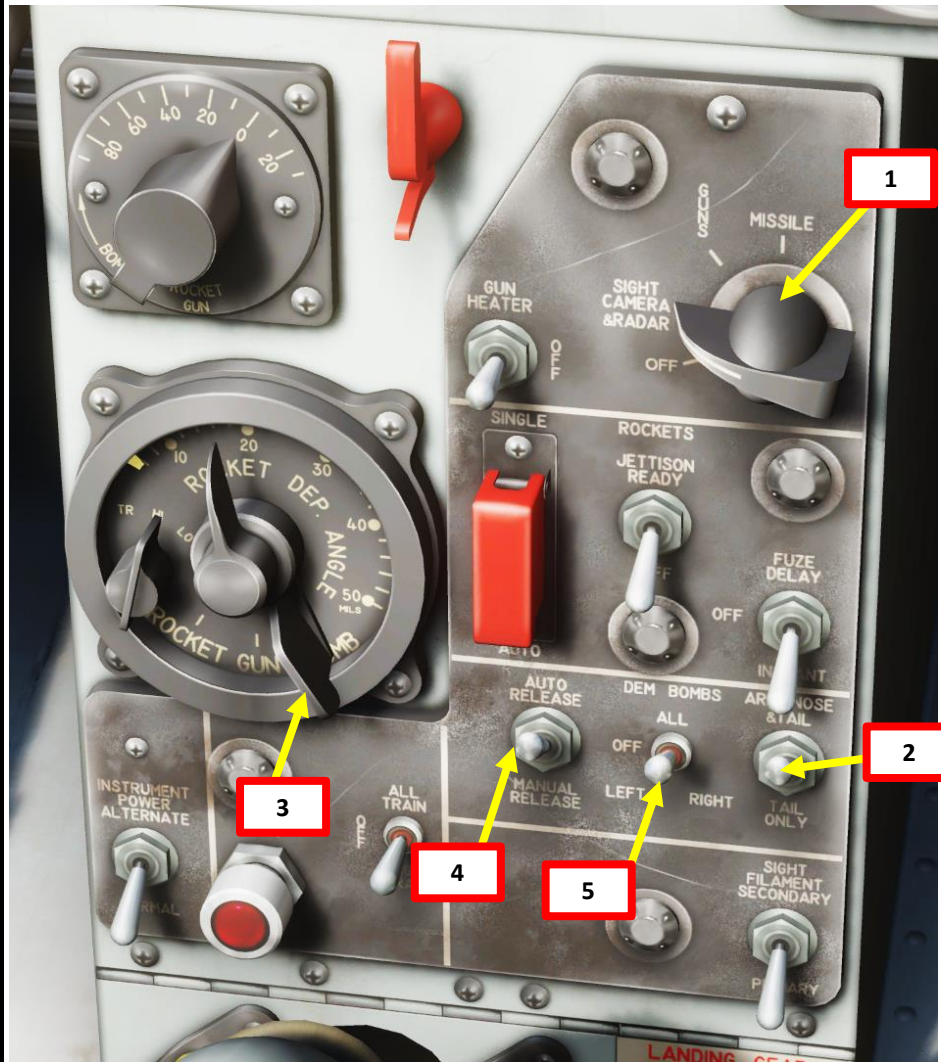

AUTOMATIC DIVE BOMBING – M64 BOMBS (500 LBS)

7. Deploy Airbrakes
8. Enter a 45-deg dive and aim the pipper reticle on the target
9. Hold Electrical Caging switch for about 3 seconds
10. While holding the Electrical Caging switch, hold your the “WEAPON RELEASE” Button (RALT+SPACE). Keep the pipper on the target.
11. Release the Electrical Caging Switch, but keep holding the “WEAPON RELEASE” Button (RALT+SPACE). You should hear a sound once your bombs are dropped automatically.

When the sight function selector lever of the sight selector unit is placed at BOMB and the sight is uncaged, the dot will automatically depress to 10° below the fuselage reference line. Therefore, if aircraft pitch is kept constant, the dot will always be placed ahead the target. Adjust the aircraft pitch to put the dot on the target. Then, to keep it on the target, place the aircraft into a curved flight path with an ever increasing pitch angle (by pushing the control stick forward). As soon as the G-load falls below 1.0, the bomb will be tripped automatically.

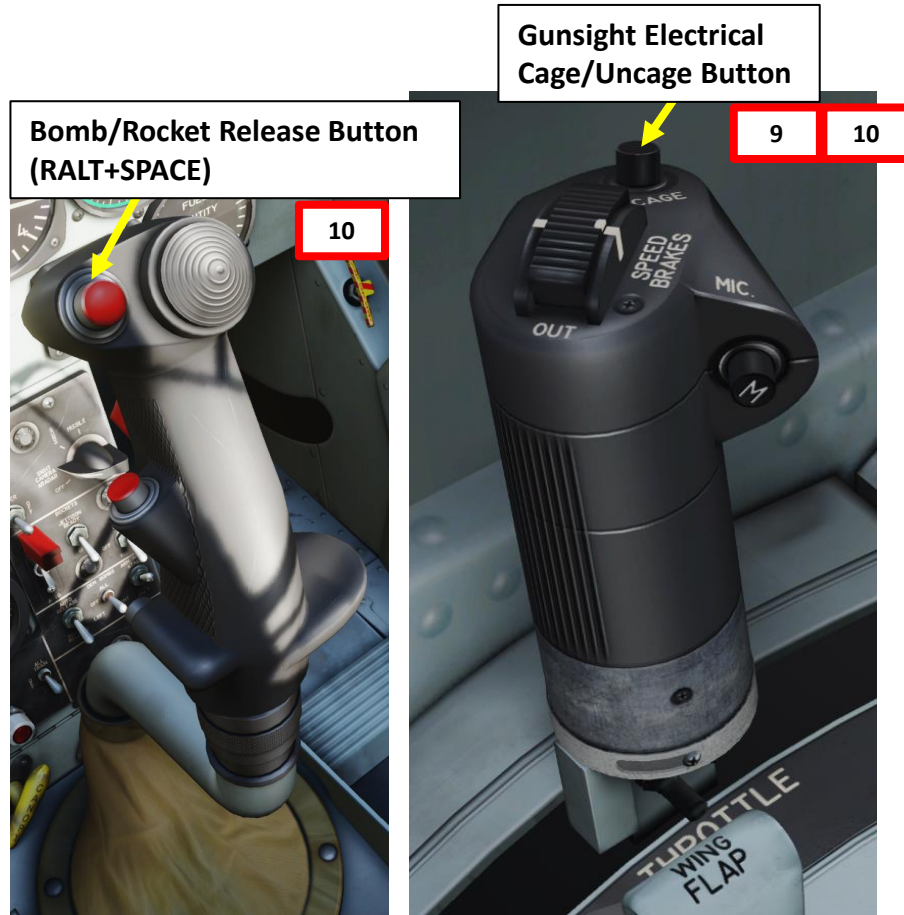

AUTOMATIC DIVE BOMBING – M64 BOMBS (500 LBS)



MANUAL PIP CONTROL (MPC) BOMBING – M64 BOMBS (500 LBS)

1. Set Weapon Mode to "SIGHT CAMERA & RADAR"
2. Set Fuze Mode to "ARM NOSE & TAIL"
3. Set Gunsight Mode to "BOMB"
4. Set Release Mode to "MANUAL"
5. Select desired Bomb Loadout to Drop (ALL/LEFT/RIGHT)
6. Uncage Mechanical Sight by setting the Mechanical Sight Cage/Uncage Lever RIGHT (Uncaged).
7. Set Manual Pip Switch Control to "BOMB".
8. Decide your starting altitude and speed. In our case, we will pick a 288 kts entry speed at 15000 ft over the target, as suggested by the Manual Pip Chart.

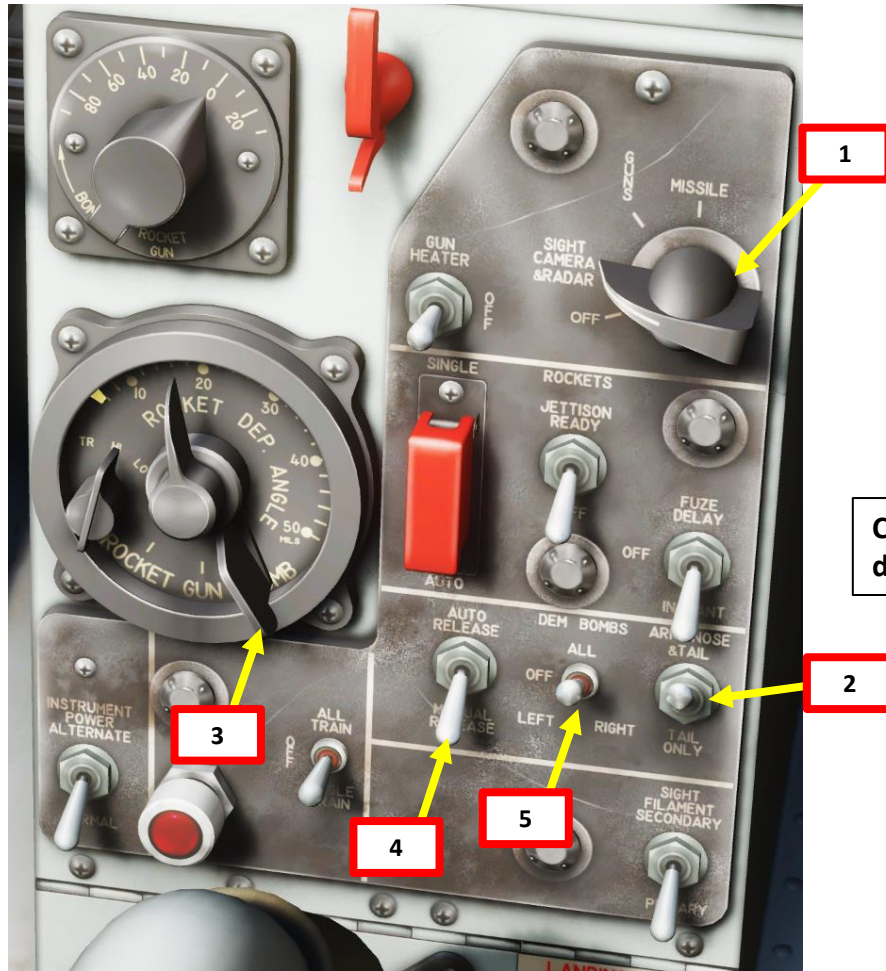

Click to toggle between different charts



MANUAL PIP CONTROL (MPC) BOMBING – M64 BOMBS (500 LBS)

9. Click on the center knob of the manual pip control and set the dive angle you intend to take. I usually take a dive angle of 50 deg. Check the associated number on the external circle, and we can deduce that for a 50-deg dive angle, starting our dive from 15000 ft at 288 kts, our bomb should be released at 4000 ft above target elevation (release parameter). Our target being at an elevation of 4800 ft, this means our bomb release altitude should be 4000 ft + 4800 ft = 8800 ft.
10. Since our eyes are glued on the piper and not on the altimeter during the dive, someone had the brilliant idea to include a bombing altimeter. Set the bombing altimeter as shown in the picture titled "CORRECT POSITION" and track the altitude needle.

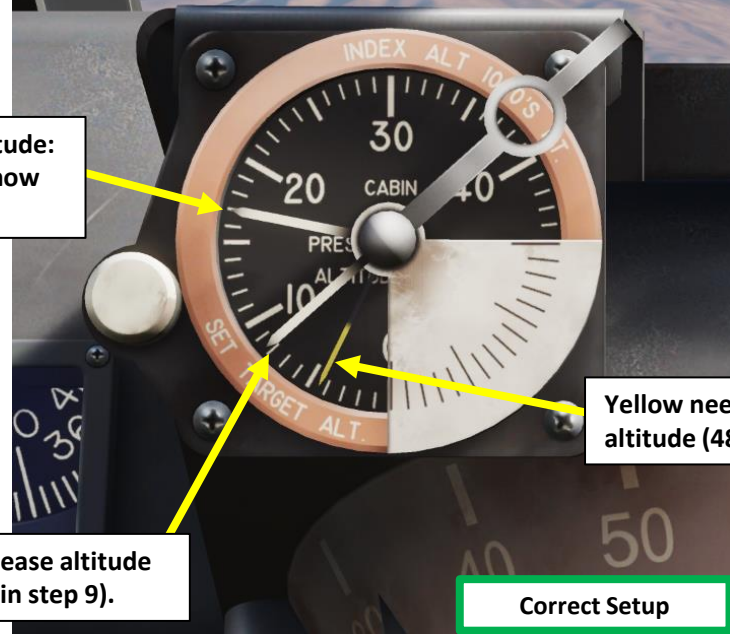

Altimeter needle points our altitude: 17000 ft. Keep an eye on it to know when to drop your bombs.

Yellow needle is set on the target altitude (4800 ft) in our case.

This needle is set on the bomb release altitude (8800 ft in our case, as suggested in step 9).

Correct Setup

9b

Suggested Bomb Release Altitude = 4000 ft above target elevation
Target Elevation = 4800 ft above ground level

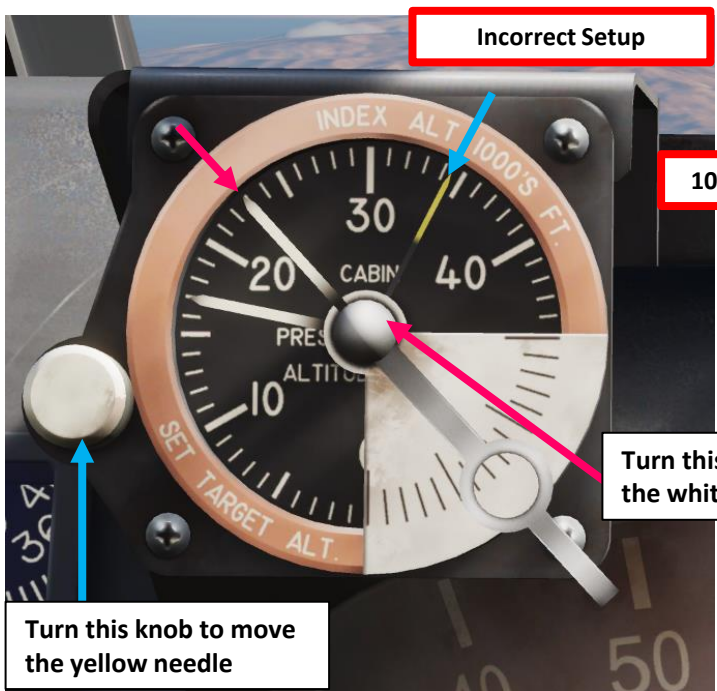
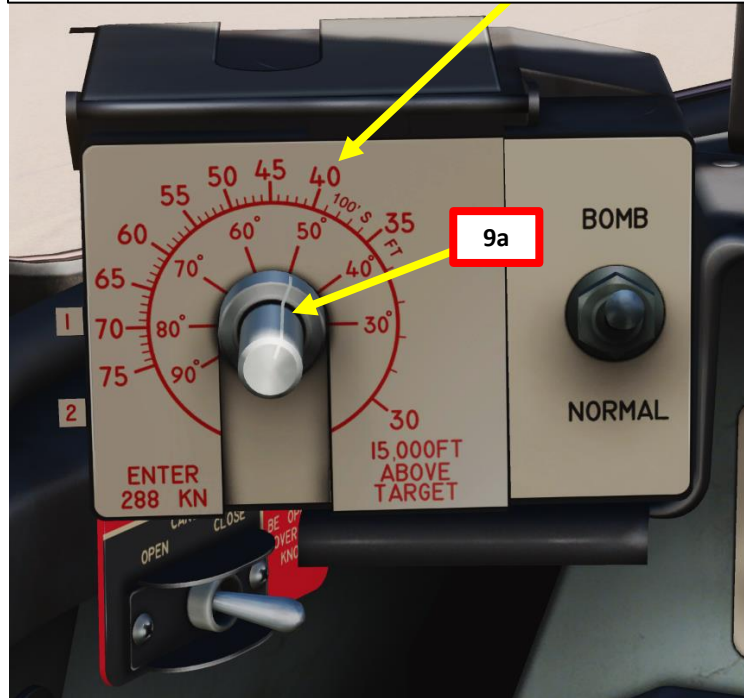

Incorrect Setup

10

Turn this knob to move the white needle

Turn this knob to move the yellow needle

MANUAL PIP CONTROL (MPC) BOMBING – M64 BOMBS (500 LBS)

11. Cut throttle, deploy airbrakes and dive for your target at a dive angle of 50 deg. Check your dive angle indicator for reference. Place the piper reticle on the target.
12. While aiming with the piper reticle, wait for the altimeter needle to meet the bomb release needle. When both needles meet, drop your ordnance by pressing the “WEAPON RELEASE” Button (RALT+SPACE) and enjoy the fireworks.



MANUAL PIP CONTROL (MPC) BOMBING – M64 BOMBS (500 LBS)



TOSS BOMBING WITH L.A.B.S. – M117 BOMBS (750 LBS)

Toss bombing (sometimes known as loft bombing, and by the U.S. Air Force as the Low Altitude Bombing System, or “LABS”) is a method of bombing where the attacking aircraft pulls upward when releasing its bomb load, giving the bomb additional time of flight by starting its ballistic path with an upward vector.

The purpose of toss bombing is to compensate for the gravity drop of the bomb in flight, and allow an aircraft to bomb a target without flying directly over it. This is in order to avoid overflying a heavily defended target, or in order to distance the attacking aircraft from the blast effects of a nuclear (or conventional) bomb.

However, the Sabre in DCS is not equipped with nuclear ordnance, so the use of the LABS system is rather impractical as the method is better suited for nuclear blasts than for precision bombing. Still, it’s a cool feature so I thought I would talk about it nonetheless.

“Over the Shoulder” Delivery



TOSS BOMBING WITH L.A.B.S. – M117 BOMBS (750 LBS)

1. Set Weapon Mode to "SIGHT CAMERA & RADAR"
2. Set Fuze Mode to "ARM NOSE & TAIL"
3. Set Gunsight Mode to "BOMB"
4. Set release mode to "MANUAL"
5. Select Bomb Loadout to drop (ALL/LEFT/RIGHT)
6. Uncage LABS Gyro (switch in the UP position)
7. Set LABS Power switch to ON (UP)
8. Set LABS Start Switch to "LABS"

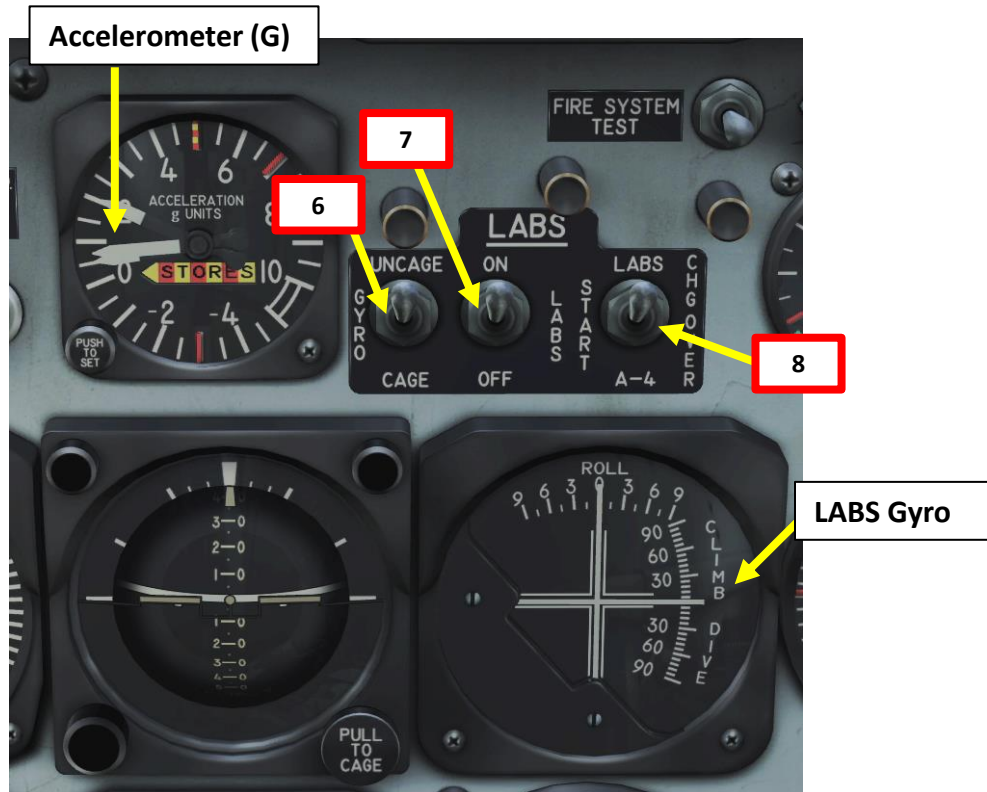

TOSS BOMBING WITH L.A.B.S. – M117 BOMBS (750 LBS)

9. Fly low until you reach your target.
10. Hold “WEAPON RELEASE” Button (RALT+SPACE) and start pulling up at a steady +4G while checking the accelerometer and the LABS gyro to avoid lateral movement as much as possible.
11. Your bombs should be released automatically if you keep holding the Weapons Release button while maintaining +4G.



Bomb/Rocket Release Button (RALT+SPACE)



TOSS BOMBING WITH L.A.B.S. – M117 BOMBS (750 LBS)



ORDNANCE JETTISON

Emergency (Mechanical) Jettison Handle

The guarded emergency jettison handle has two distinct release positions and permits selective mechanical release of external loads. Rotating the handle clockwise to a detent stop and then pulling it out as far as possible (about 4 inches) releases only the outboard drop tanks. If the outboard tanks are finless, 200-gallon drop tanks, this jettison procedure additionally causes an explosive charge to fire which forcibly jettisons the tanks. All drop tanks (or all external loads) are released simultaneously when the handle is pulled, without rotation, to its full extension of approximately 10 inches. When the cable is pulled, all weapons are disarmed automatically, irrespective of relevant switch positions.



Emergency Jettison Lever

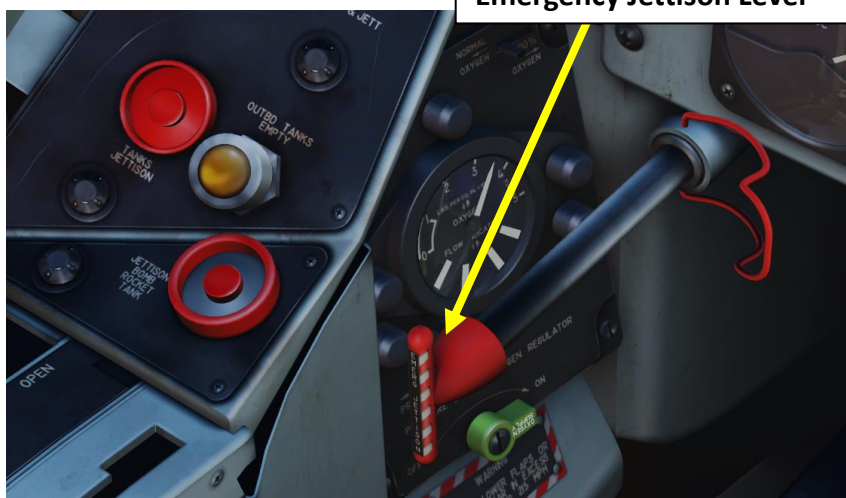

ORDNANCE JETTISON

Electric Jettison

The “Jettison Bombs-Rockets-Fuel-Tanks” Button permits a jettison of all stores (except for GAR-8 missiles). Bombs and rockets will be dropped unarmed.



Jettison Bombs, Rockets & Fuel Tanks Button
Press to jettison the bombs/rockets/fuel tanks selected



ORDNANCE JETTISON

Rocket Jettison

1. Set Rocket Jettison Switch – ON (UP).
2. Set “WEAPON RELEASE” Button (RALT+SPACE) to jettison rockets.



ORDNANCE JETTISON

Missile Jettison

1. Set weapon selector to "MISSILE".
2. Press the Missile Jettison Button.



Missile Jettison Button



SKINS

Skins must be installed in the directory shown in the picture below.

Sometimes the folder is not there. Create one manually called "F-86F Sabre" to be able to stock these sweet skins.

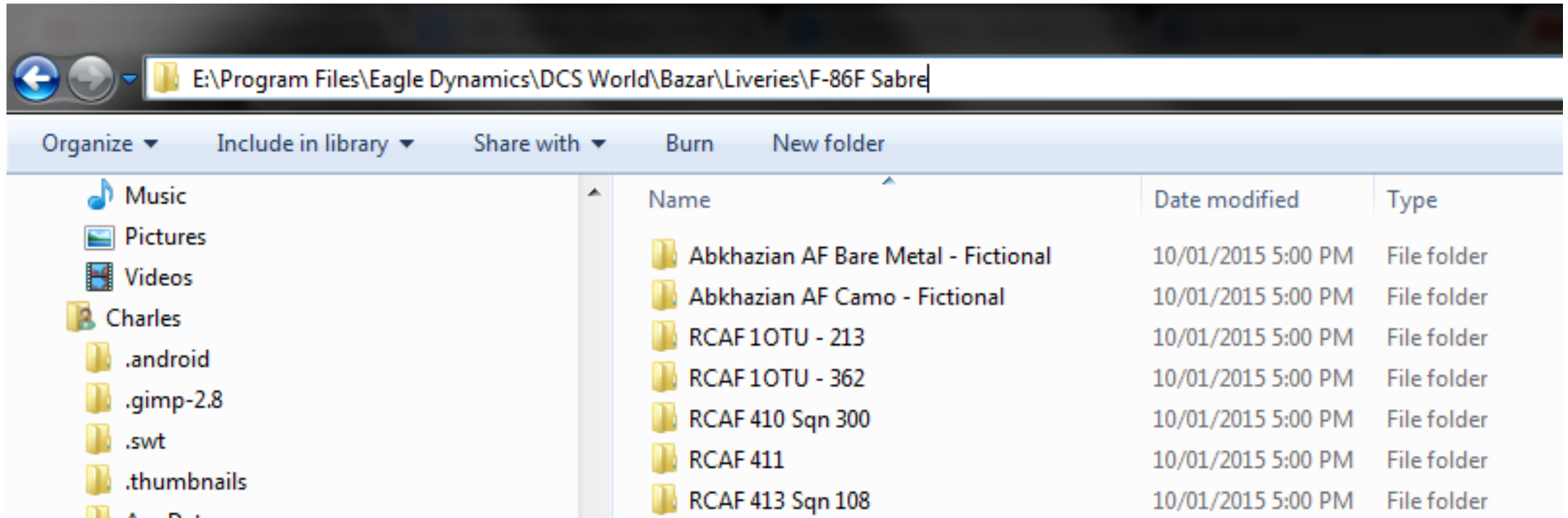



AN/ARC-27 UHF RADIO TUTORIAL

The AN/ARC-27 UHF radio of the Sabre has 19 preset channels with a **frequency band going from 225 to 339.9 MHz**. Each frequency is mapped individually and manually by the mission builder. The channel frequencies should be available in the Mission Briefing or mission description if the mission builder wanted to make your life easier.

To transmit on the radio:

1. Set Radio Power Switch to either T/R or T/R+G REC
2. Select desired Radio Preset Channel.
3. Adjust radio volume as desired.
4. Transmit using the Microphone Button (RALT+).

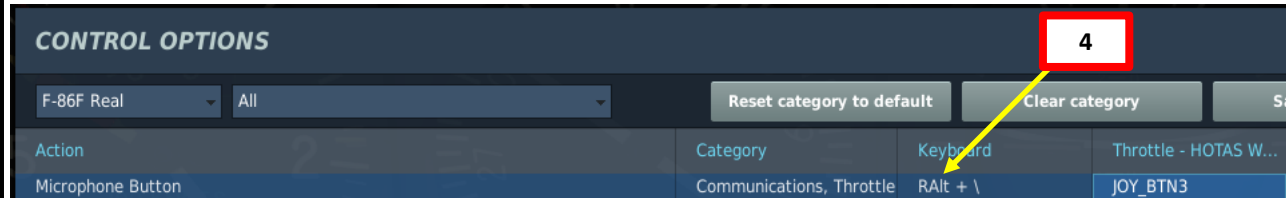

Radio Power Switch

1

- OFF
- T/R: Transmit/Receive
- T/R+G REC: Transmit/Receive + Emergency Guard Channel Receiver
- ADF: Automatic Direction Finder (function not implemented)

Radio Preset Channel Selector 2

Radio Volume Control 3

4 Microphone Button (RALT+)

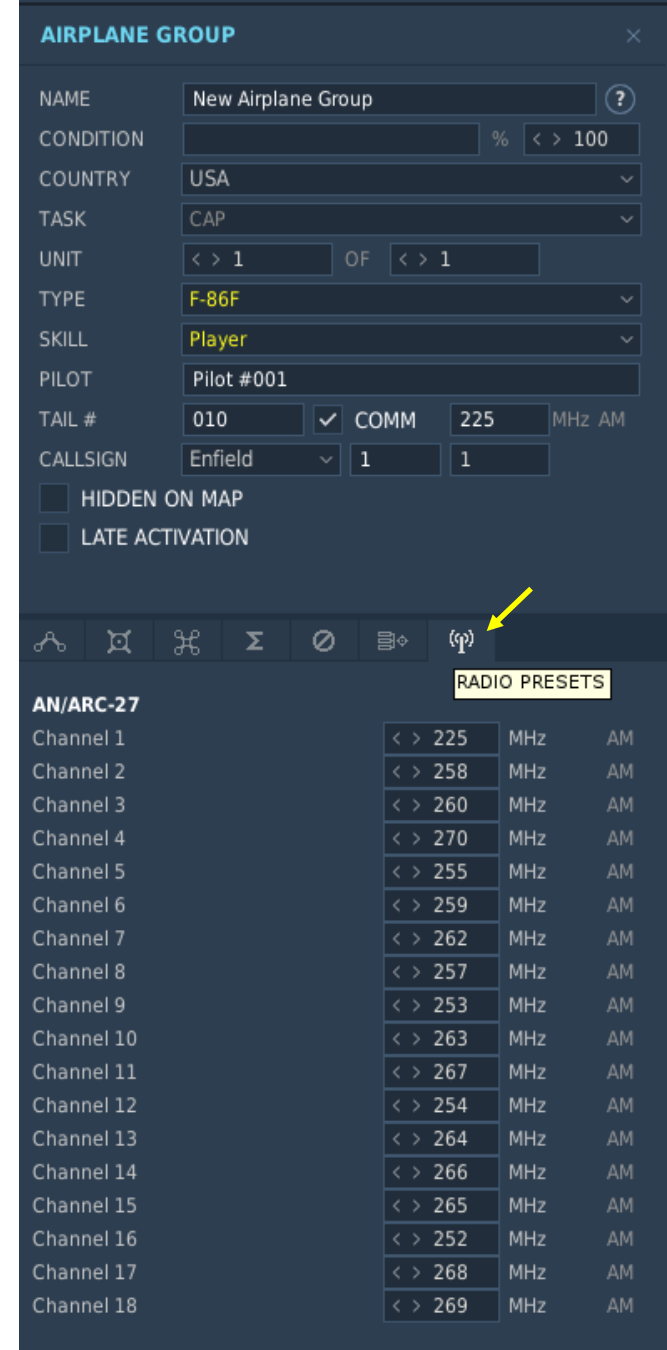
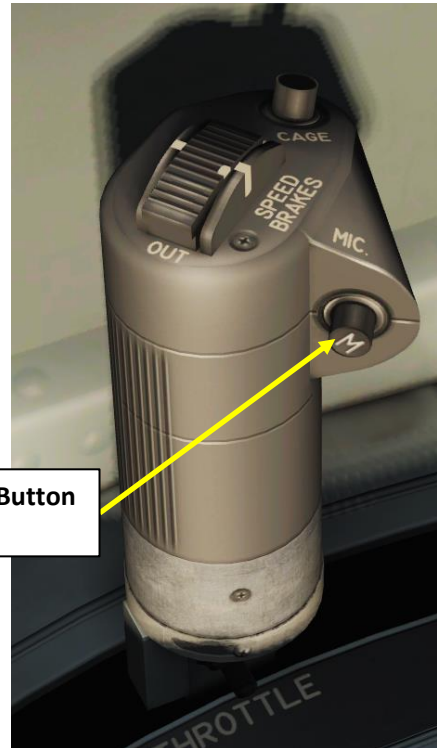

BASIC NAVIGATION EQUIPMENT

In the Sabre, navigation is mostly done visually, as was the case in the 1950's. The Slaved Gyro-Compass provides you with your current magnetic heading. The conventional magnetic compass is a back-up device for determining the aircraft's magnetic heading. It is installed to allow navigation in case of instrument or electrical system failure. The Radio-Compass pointer is used for radio-navigation.



Radio-Compass Pointer
Relative Bearing of NDB in relationship to you

Magnetic Compass Fast Slave Button

Slaved Gyro-Compass Current heading

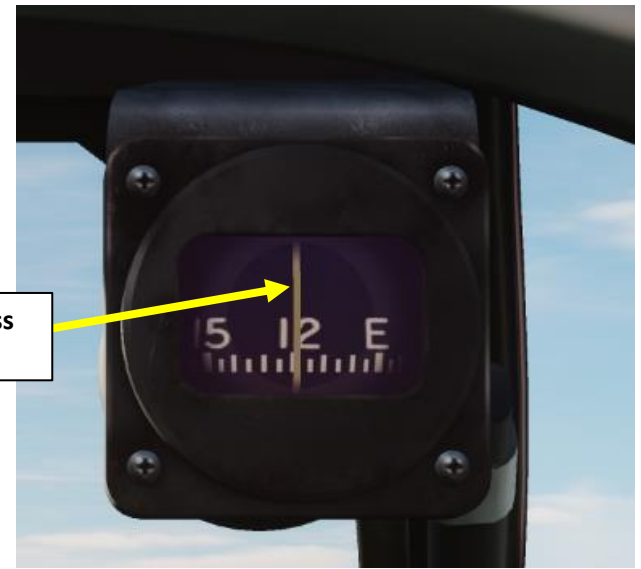

Magnetic Compass Current heading

AN/ARN-6 RADIO NAVIGATION

We will use a “NDB” (Non-Directional Beacon) for radio compass navigation. These NDBs are located at various airfields and certain places. Take note that they are hardcoded in the map.

NDBs transmit a morse code on a set frequency that can be heard with the AN/ARN-6 Radio Compass. The source of the signal can be detected with the radio compass on the main instrument panel (its arrow will tell you where the signal you are receiving is coming from).

There can be many NDBs transmitting at frequencies that are very close to one another, so it can be easy to follow another signal by mistake.

Radio tuning is very precise and sensitive. The only reliable way to know if you are tracking the good signal is to listen to the morse code signal emitted by the beacon and verify that it matches.

All Beacons and their respective morse codes are listed in [LINO GERMANY'S BEACON MAP](#) available here:





DIRECT DOWNLOAD: <https://drive.google.com/open?id=0B-uSpZROuEd3YWJBUmZTazBGajQ&authuser=0>

In the following example, I will fly from Sukhumi Airfield (which already has 2 NDBs next to it transmitting other signals on their own frequencies).

- The signal I will track is a NDB near the small town of Gali. The beacon map tells me that the beacon is transmitting on a frequency of 525.00 KHz and that the morse code is – . . . –
- I can associate the morse code with one long beep, followed by two short beeps, followed by a pause, followed by a short beep and followed by a long beep.
- Take note that if you fly under 6000 ft, there might be interferences from ground clutter.

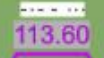

AN/ARN-6 RADIO NAVIGATION

	NDB (Non Directional Beacon) with corresponding frequency in kHz and morse code.
	Combination of NDB and inner or outer marker. NDB with corresponding frequency in MHz and morse code.
	ILS (Instrument Landing System) with corresponding frequency in MHz, direction of the runway and morse code.
	VOR (VHF Omnidirectional Radio Range) with corresponding frequency in Mhz and morse code.
	TACAN (Tactical Air Navigation) with corresponding channel and morse code.
	RSBN (VOR) and PRMG (ILS) Channel with corresponding morse code.

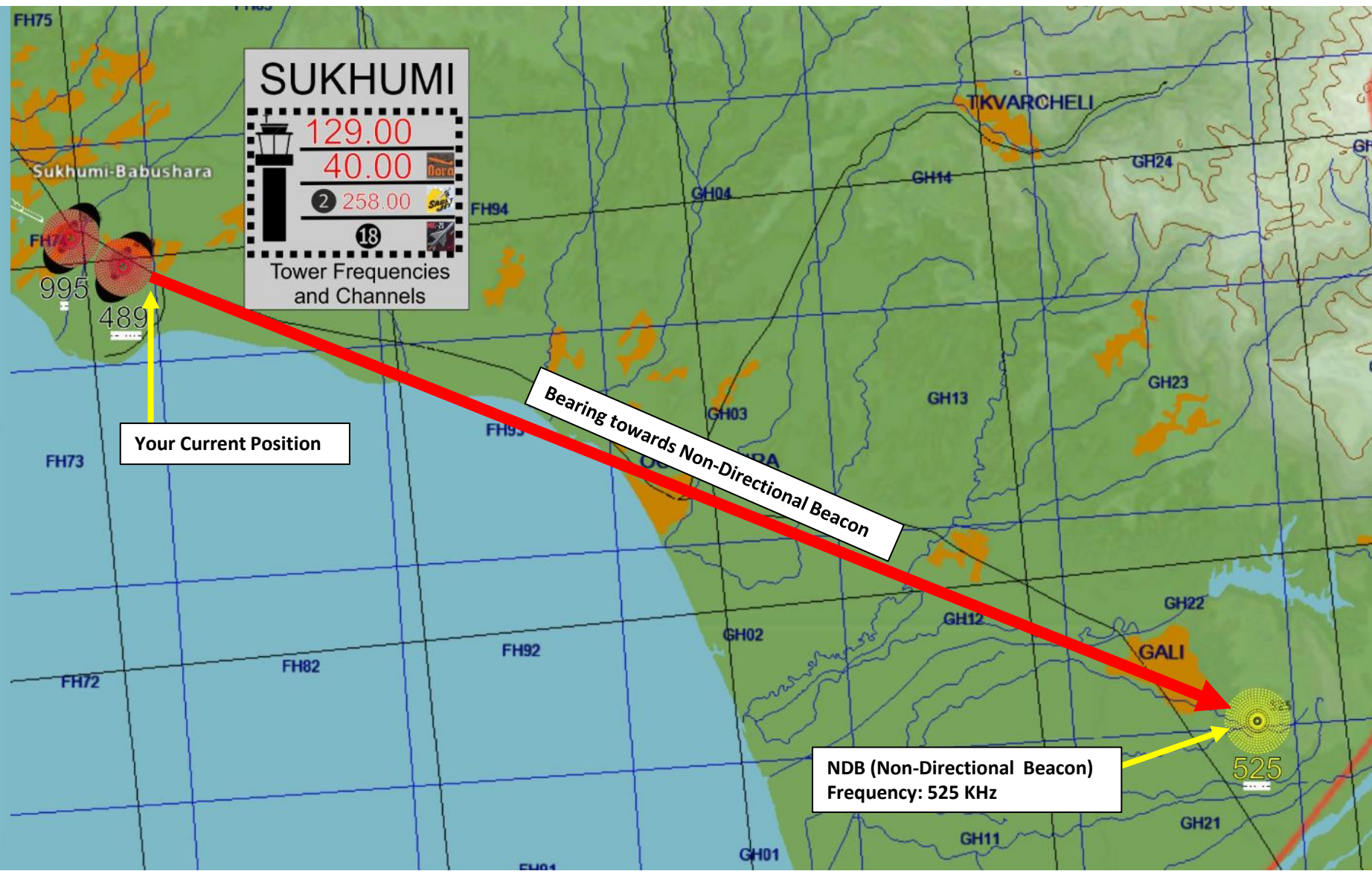

AN/ARN-6 RADIO NAVIGATION

In this example, we want to navigate to a NDB with a **frequency of 525.00 KHz**.

1. Set AN/ARN-6 Mode Selector to COMP (Compass)
2. Set frequency range selector to 410-850 KHz band range since we are looking for a NDB frequency of 525 KHz.
3. Fine tune frequency by turning the Tuning crank. Use the Signal Strength needle as a reference to estimate if you are tuned in properly.
4. Once the signal strength is strong enough (needle should be pointing to the right), you should be able to hear the morse code of the NDB station.
5. Adjust volume and listen to the morse code signal to verify that you are tracking the right signal. Keep tuning if the signal is wrong.

AN/ARN-6 Mode Selector

- OFF turns the unit off.
- COMP (Compass): puts the unit in compass mode (primary mode of use).
- ANT (Antenna): puts the unit in antenna sensing mode (for fine frequency tuning).
- LOOP: puts the unit in loop mode (for loop antenna functional test).
- CONT: Not simulated

2a Frequency Band Selector

- 100 to 200 kHz
- 200 to 410 kHz
- 410 to 850 kHz
- 850 to 1750 kHz

3 Frequency Tuning Crank

AN/ARN-6 Signal Strength Indicator

4

Loop Rotation Switch

Allows the loop antenna to be manually rotated to the left (L) or right (R) when LOOP function is selected

Frequency Indicator

2b

Display Light Control Switch

Controls the brightness of the back light on the tuning meter and the band and frequency display

- FWD: High Brightness
- MIDDLE: OFF
- AFT: Low Brightness

Volume Control

5

CW (Continuous Wave) Voice Oscillator Switch

- Not Simulated

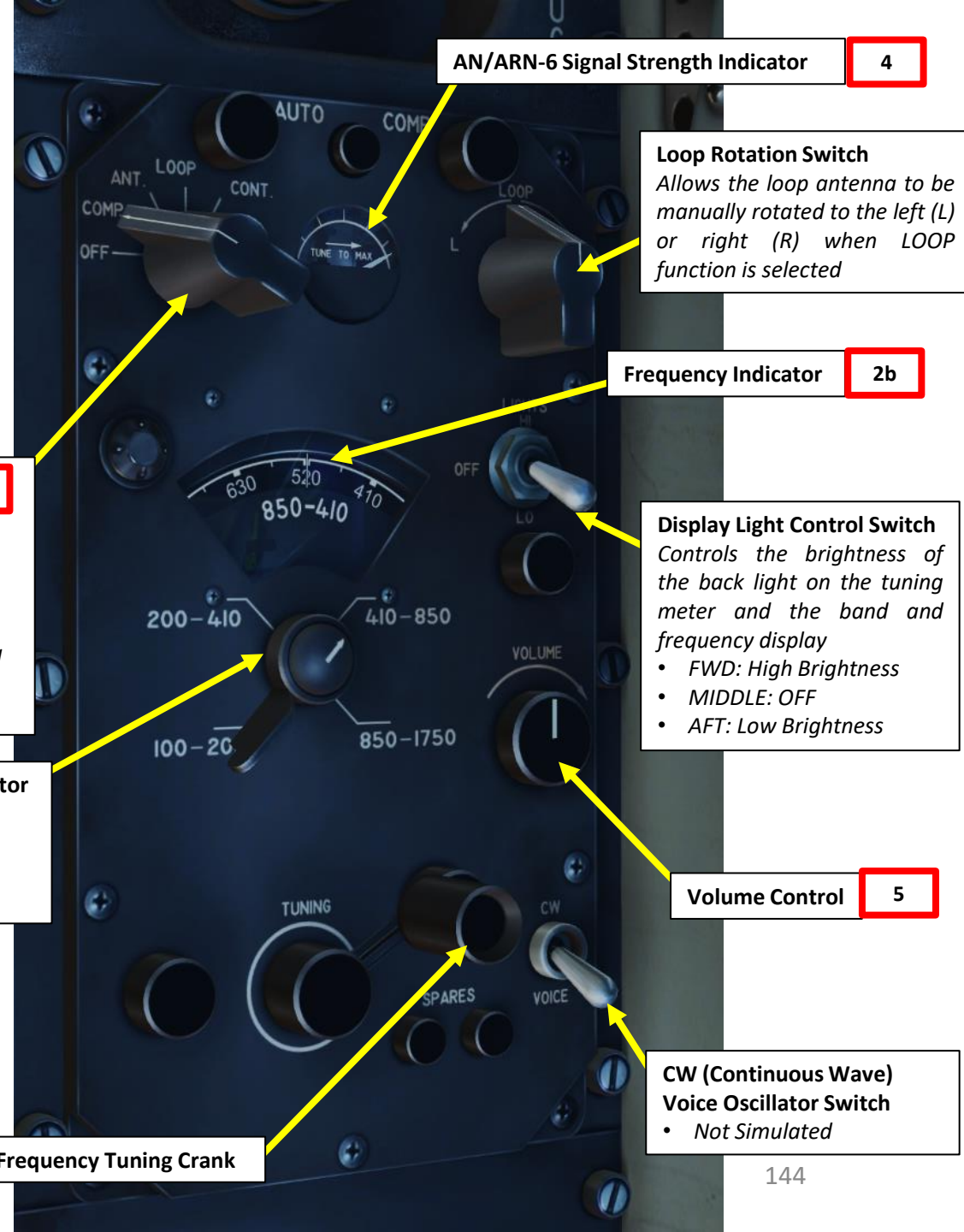

AN/ARN-6 RADIO NAVIGATION

- The needle of the Radio Compass will give you a bearing to get to the source of the signal. Use common sense to see if the frequency you are receiving is pointing in the right direction. If the signal is pointing in the reverse direction, you are probably tracking another beacon that has a similar frequency as the one you are looking for. The task can become a chore if there are many beacons transmitting in the same frequency range. The **pointer indicates the relative bearing to the transmitter**, i.e. the direction to the desired station relative to the aircraft's nose. The 12 o'clock position (marked by a fixed index, the so-called "top index") represents the nose of the aircraft and the 6 o'clock position the tail. The relative bearing, the angle measured clockwise from the nose of the aircraft to the station, is indicated by the needle. If the needle points straight up, the aircraft is flying towards the transmitter.
- When the needle swings around 180 degrees, the transmitter has just been overflowed. When the true magnetic heading of the aircraft is set under the top index, the pointer will indicate the magnetic bearing to the station instead of the relative bearing. The indicator's bearing scale can be manually rotated with the knob labeled "VAR." located on the front of the indicator.

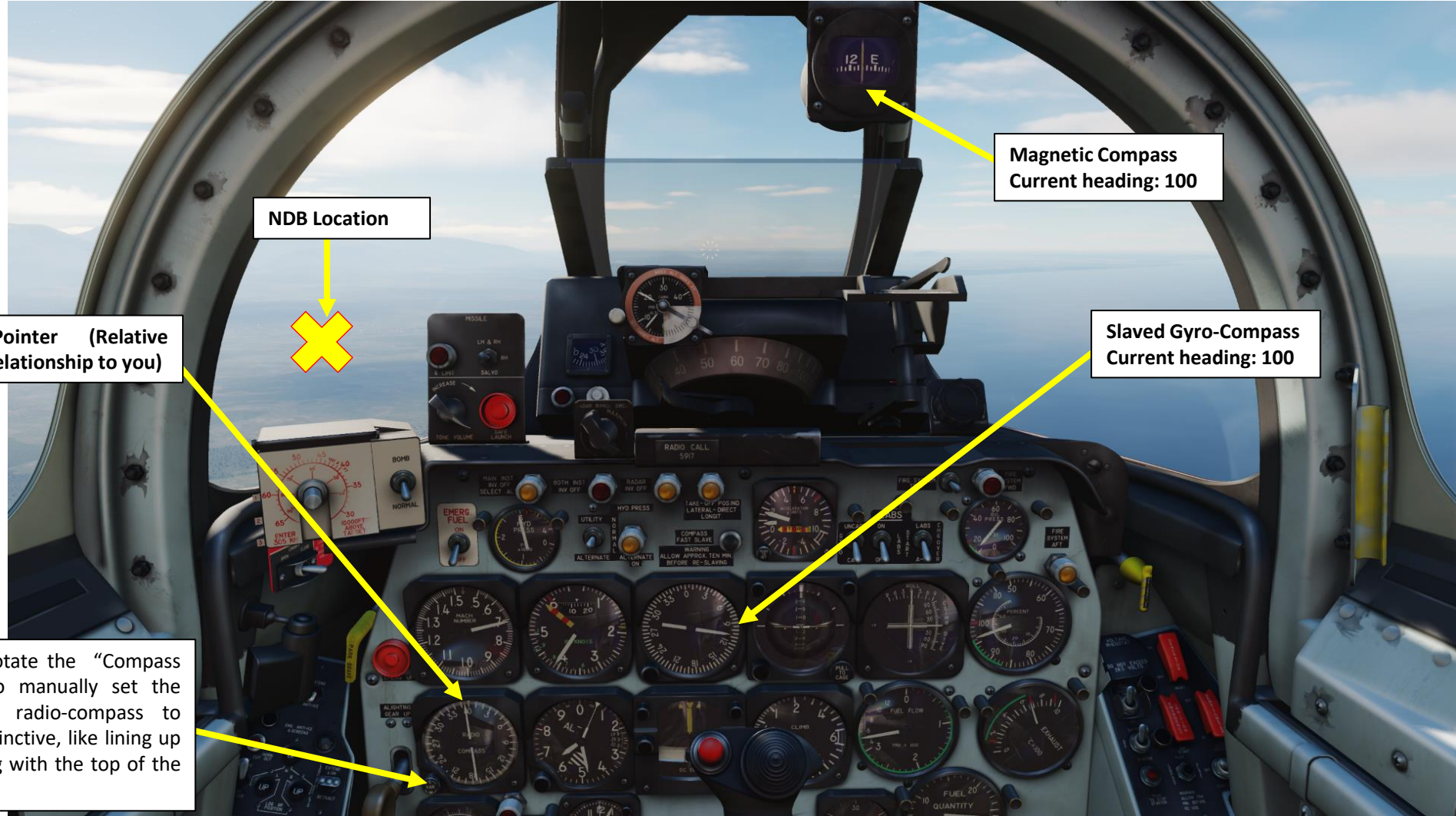

NDB Location

Magnetic Compass
Current heading: 100

Radio-Compass Pointer (Relative
Bearing of NDB in relationship to you)

Slaved Gyro-Compass
Current heading: 100

Optional: you can rotate the "Compass Correction" knob to manually set the orientation of the radio-compass to something more instinctive, like lining up your current heading with the top of the gauge.

AN/ARN-6 RADIO NAVIGATION

- 8. Following the heading prescribed by the **Radio Compass Pointer** and verifying with my map, the beacon signal I am tracking appears to be in this area, which makes sense since I am flying over Sukhumi at this time and the beacon should be at my South-West (approx. a heading of 110). At the moment, my current heading is 120 as per the magnetic compass.

Radio-Compass Pointer
Relative Bearing of NDB in relationship to you
In this example: NDB is straight ahead in front of you

Magnetic Compass
Current heading



Slaved Gyro-Compass
Current heading



MAGNETIC DEVIATION

The direction in which a compass needle points is known as magnetic north. In general, this is not exactly the direction of the North Magnetic Pole (or of any other consistent location). Instead, the compass aligns itself to the local geomagnetic field, which varies in a complex manner over the Earth's surface, as well as over time. The local angular difference between magnetic north and true north is called the magnetic declination. Most **map coordinate** systems are based on **true north**, and magnetic declination is often shown on map legends so that the direction of true north can be determined from north as indicated by a compass. This is the reason why in DCS, the course to a runway needs to be "adjusted" to take into account this magnetic declination of the magnetic North pole (which is actually modelled in the sim, which is pretty neat).

True Heading = Magnetic Heading + Magnetic Deviation

As an example, if the runway heading that you read on the F10 map in Kutaisi is 074 (True Heading), then the direction you should take with your magnetic compass course should be 074 subtracted with the Magnetic Deviation (+6 degrees), or 068. In other words, you would need to use a course of 068 (M) with your compass.

Magnetic Declination:

- +6.4 deg for Caucasus
- +14.2 deg for Nevada
- +1.3 deg for Persian Gulf
- -5 deg for Normandy
- +0.2 deg for the English Channel
- +5.2 deg for Syria
- +0.9 deg for Marianas

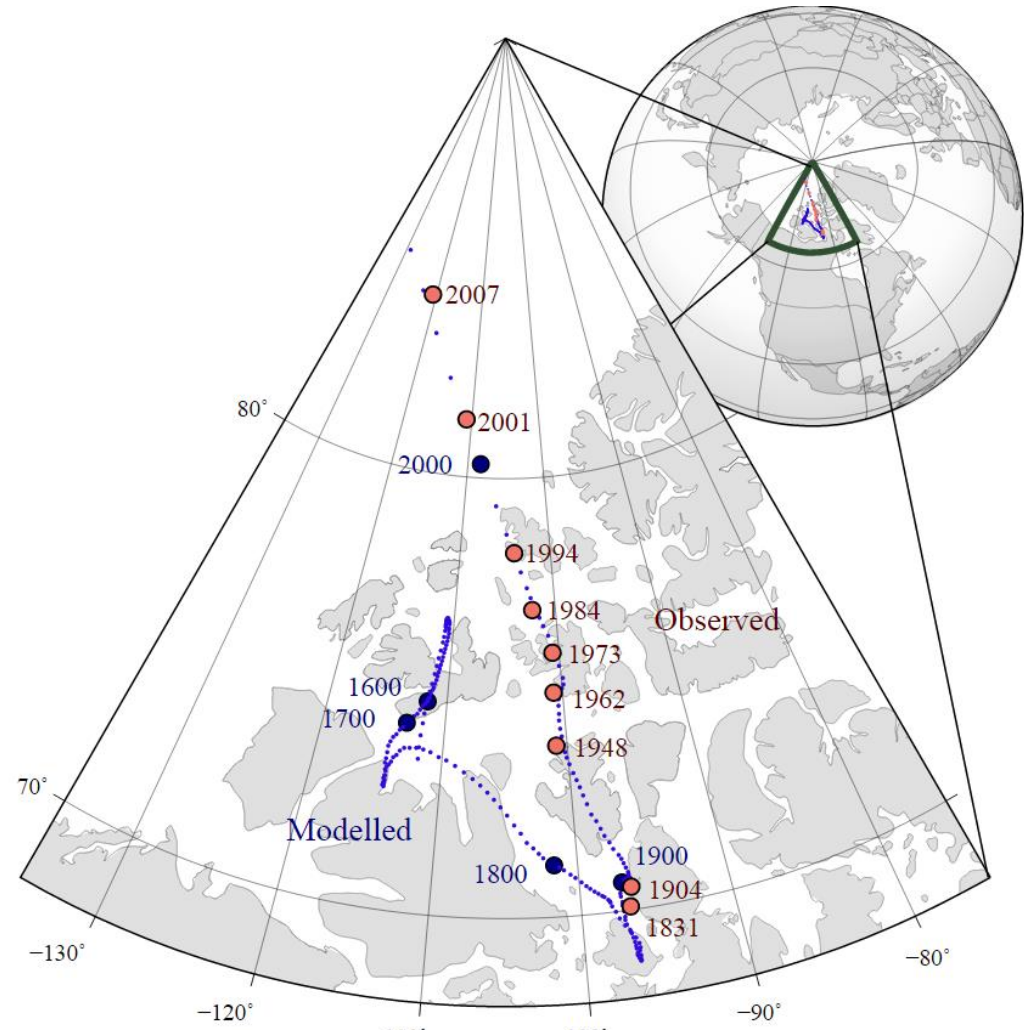
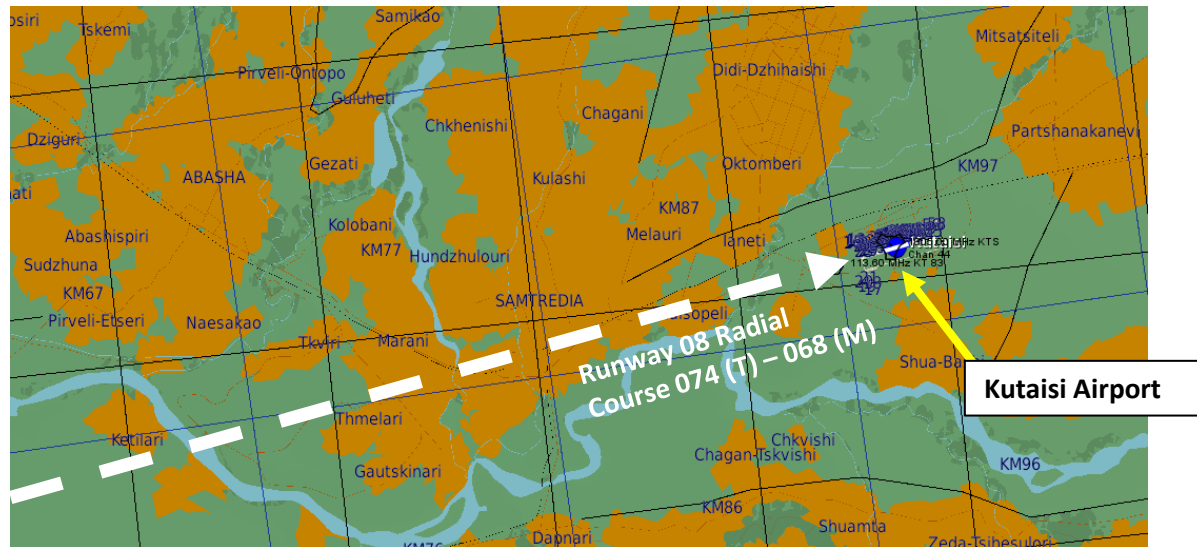

The movement of Earth's north magnetic pole across the Canadian arctic, 1831–2007.

MAGNETIC DEVIATION

Checking the magnetic declination is now very easy: you can access it directly from the F10 map, shown with the Compass Rose.

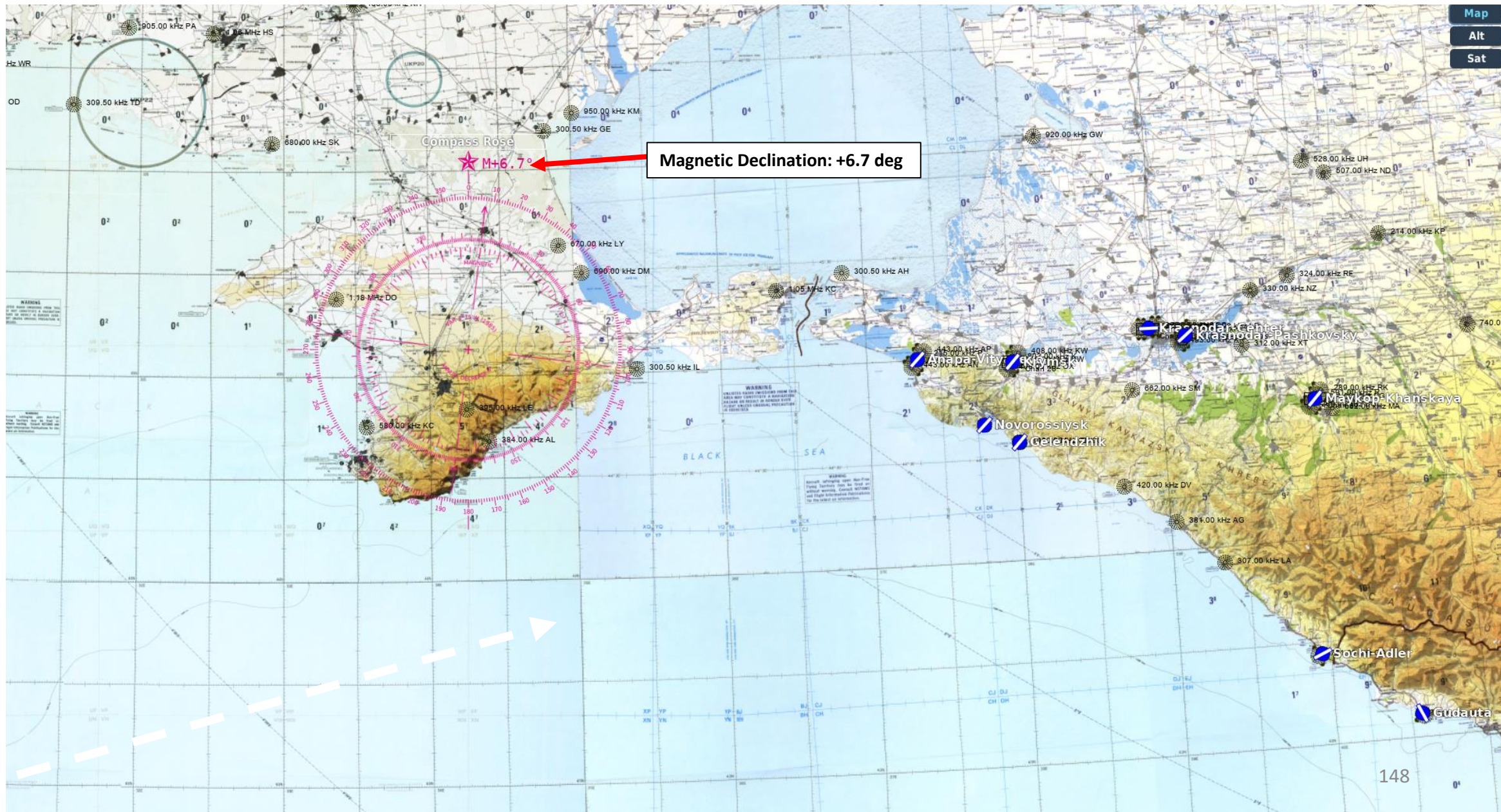



IFF (IDENTIFY-FRIEND-OR-FOE) SYSTEM INTRODUCTION

In its simplest form, a IFF "Mode" or interrogation type is generally determined by pulse spacing between two or more interrogation pulses. Various modes exist from Mode 1 to 5 for military use, to Mode A, C, and Mode S for civilian use. The takeaway from this table should be:

- **Mode 4 is the preferred mode in a combat scenario** because it is highly secure (encrypted). Encrypted interrogation codes cannot be detected by an enemy transponder, and your transponder will not broadcast a reply signal to the other team.
- **Mode 4 invalid/lack of reply cannot guarantee that an aircraft is hostile, but a valid reply is a guarantee of a friendly contact** (within DCS)
- **Modes 1, 2, and 3 are not secure to use** since any other aircraft from the opposing team could find what your Interrogator code is and set his transponder to it, fooling you into thinking he is a friendly contact. These modes also easily give away your position since every time your transponder broadcasts an answer, this signal can be intercepted by an enemy transponder, which can send your position to other enemy fighters via datalink.

Military Interrogation Mode	Civilian Interrogation Mode	Description
1		Provides 2-digit 5-bit mission code
2		Provides 4-digit octal unit code (set on ground for fighters, can be changed in flight by transport aircraft)
3	A	Provides a 4-digit octal identification code for the aircraft, set in the cockpit but assigned by the air traffic controller. Mode 3/A is often combined with Mode C to provide altitude information as well.
	C	Provides the aircraft's pressure altitude and is usually combined with Mode 3/A to provide a combination of a 4-digit octal code and altitude as Mode 3 A/C, often referred to as Mode A and C
4		Provides a 3-pulse reply, delay is based on the encrypted challenge
5		Provides a cryptographically secured version of Mode S and ADS-B GPS position
S		Mode S (Select) is designed to help avoiding overinterrogation of the transponder (having many radars in busy areas) and to allow automatic collision avoidance. Mode S transponders are compatible with Mode A and Mode C Secondary Surveillance Radar (SSR) systems. This is the type of transponder that is used for TCAS or ACAS II (Airborne Collision Avoidance System) functions



F-86F
SABRE

PART 14 – AN/APX-6 TRANSPONDER (IFF)

IFF (IDENTIFY-FRIEND-OR-FOE) SYSTEM

The AN/APX-6 IFF (Identify-Friend-or-Foe) Transponder system is fairly simple:

1. Set IFF Master Switch to NORM (Normal)
2. Set Modes as required by the mission. As an example, we will assume Mode 3 is used and it has a fictional preset code of 1225 already programmed.
3. If you are interrogated with mode 3 with a code set to 1225, the transponder will then send a response signal (reply) to the interrogator with the transponder code you are equipped with.

AN/APX-6 IFF Mode 2 Selector

AN/APX-6 Self-Destruct Button

AN/APX-6 IFF Mode 3 Selector

2

AN/APX-6 IFF Master Switch

- EMERGENCY
- NORM (Normal)
- LOW
- STANDBY

1

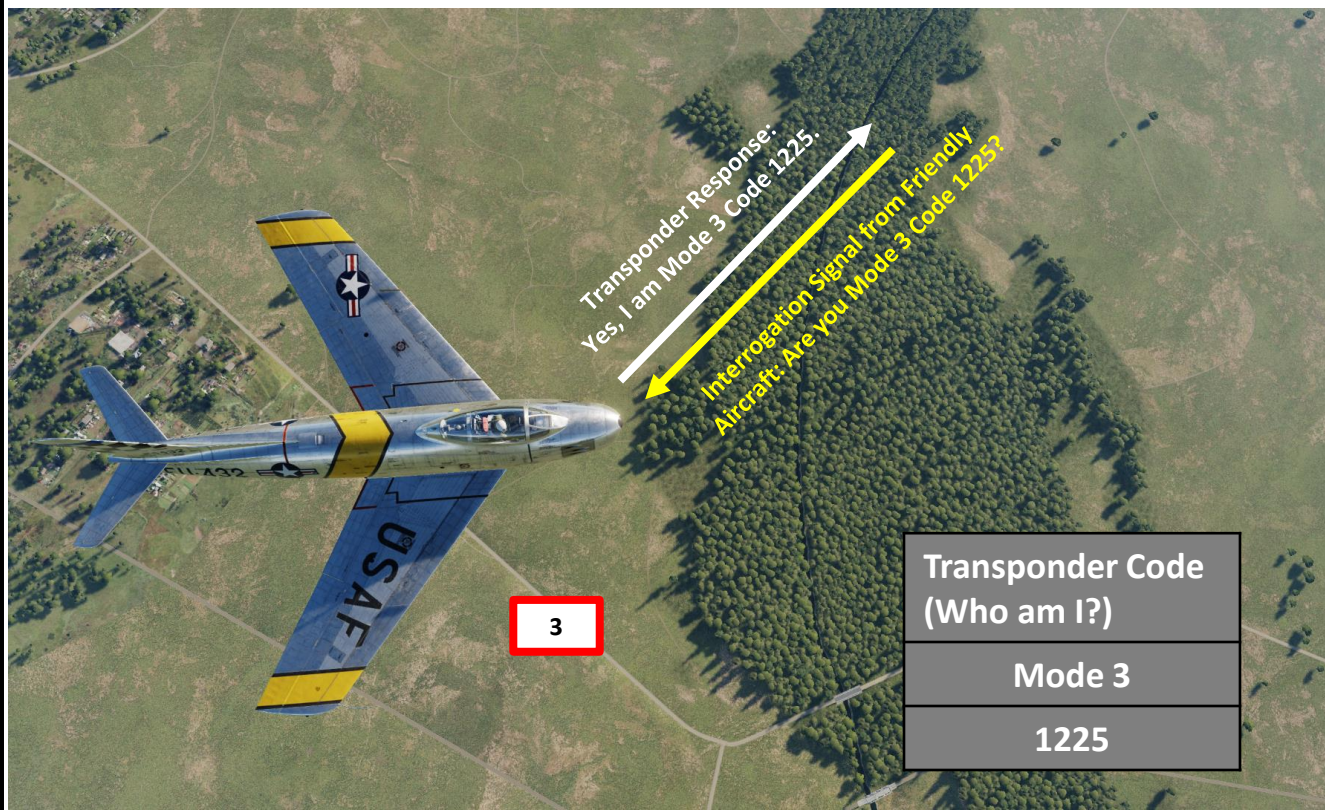
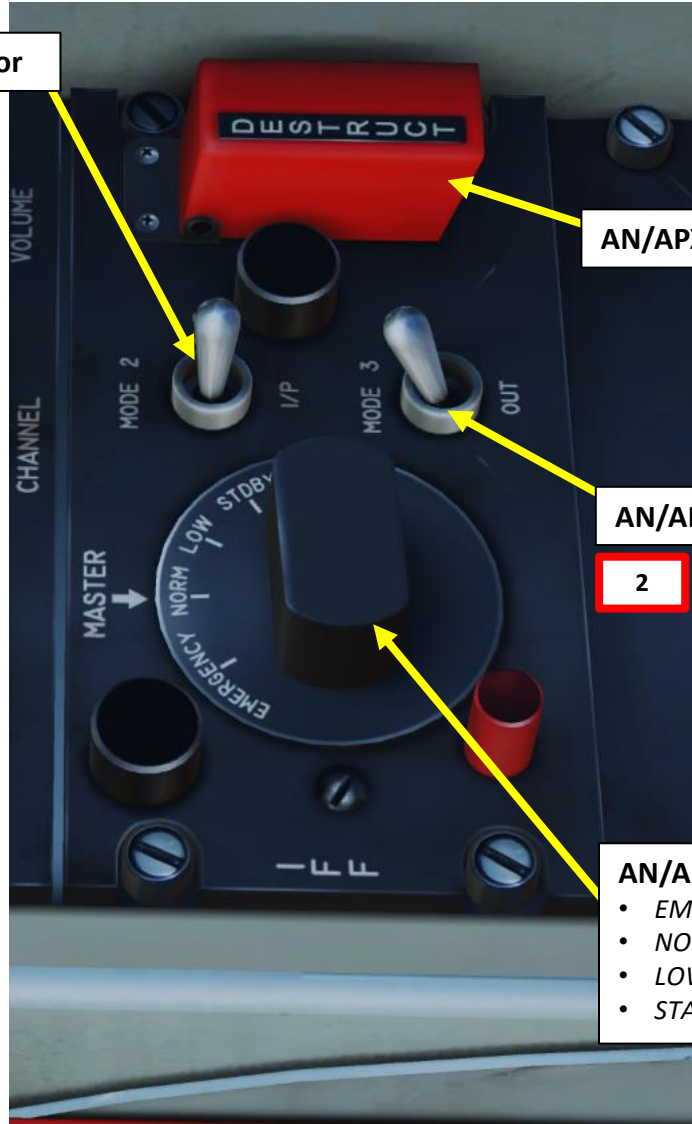

Transponder Response:
Yes, I am Mode 3 Code 1225.

Interrogation Signal from Friendly
Aircraft: Are you Mode 3 Code 1225?

3

Transponder Code
(Who am I?)

Mode 3

1225



COMBAT TIPS & TRICKS

You should consult "No Guts, No Glory", an excellent textbook written by USAF Major General Frederick C. Blesse (Ret.). It has excellent insight on how the Sabre should be flown in combat scenarios.

LINK: <https://drive.google.com/open?id=0B-uSpZROuEd3T1RudnIMWVGZ6OVE&authuser=0>

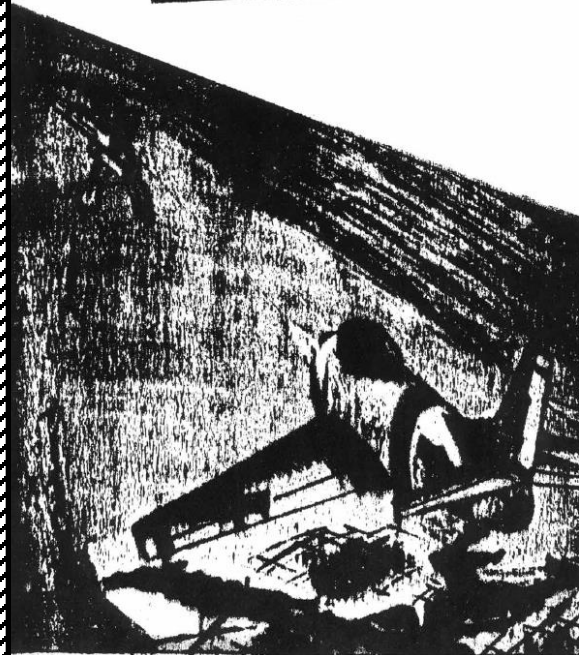

**NO GUTS
NO GLORY!**



**WHEN YOU'RE TOLD TO BREAK
DO IT!!!**

BENNETT

REVERSING A TURN

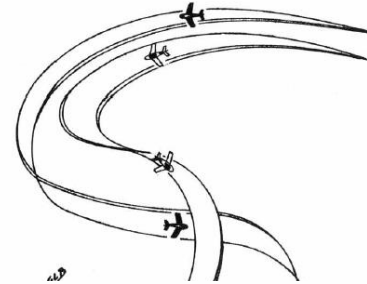

SCISSORS MANEUVER

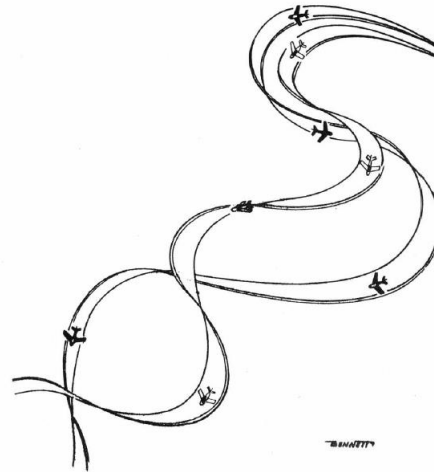

BENNETT

**A GOOD WINGMAN NEVER
LOSES HIS LEADER !!**

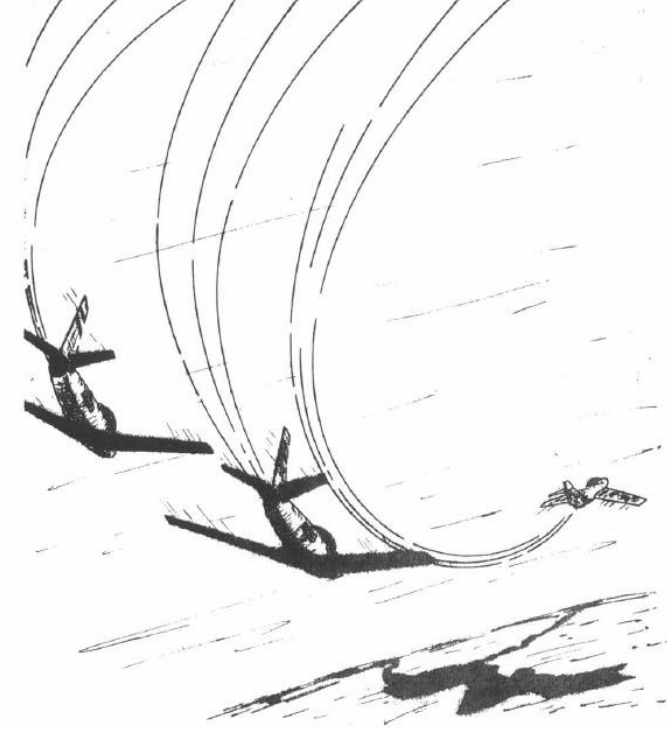



F-86F
SABRE

RESOURCES

• BUNYAP SIMS YOUTUBE CHANNEL

- MAIN CHANNEL: <https://www.youtube.com/user/4023446/videos>
- RADIO COMMS TUTORIAL: <https://www.youtube.com/watch?v=xa6TsnbG5pl>
- MANUAL PIP BOMBING SYSTEM: https://www.youtube.com/watch?v=tbDON_t_FZw

• XXJOHNXX YOUTUBE CHANNEL

- MAIN CHANNEL: <https://www.youtube.com/user/4023446/videos>
- SABRE TUTORIALS: https://www.youtube.com/playlist?list=PLs4yzB9MM2Sx_BSiYcQkTnT4Ei2vtxUy
- LABS TUTORIAL: https://www.youtube.com/watch?v=uXWOb_B5zpM

• 504SMUDGE YOUTUBE CHANNEL

- <https://www.youtube.com/user/504smudge/featured>

• LABS TUTORIAL: “Nuclear War: "Delivery of Atomic Weapons by Light Carrier Aircraft" 1959 US Navy Training Film”

- https://www.youtube.com/watch?v=3dlqfN_aPtY

• LINO GERMANY BEACON MAP

- <https://drive.google.com/open?id=0B-uSpZROuEd3YWJBUMZTazBGajQ&authuser=0>

THANK YOU TO ALL MY PATRONS

Creating these guides is no easy task, and I would like to take the time to properly thank every single one of my [Patreon](#) supporters. The following people have donated a very generous amount to help me keep supporting existing guides and work on new projects as well:

- [ChazFlyz](#)

F-86F SABRE



INSTANT ACTION
CREATE FAST MISSION
MISSION
CAMPAIGN
MULTIPLAYER

LOGBOOK
ENCYCLOPEDIA
TRAINING
REPLAY

MISSION EDITOR
CAMPAIGN BUILDER

EXIT



F-86F
1.5.5



FC3
1.5.5



Fw 190 D-9
1.5.5



Hawk
1.5.5 Beta



Ka-50
1.5.5



L-39
1.5.5



M-2000C
1.5.5 Beta



Mi-8MTV2
1.5.5



MiG-15bis
1.5.5



MiG-21bis
1.5.4



P-40F
1.5.4 Beta



P-51D
1.5.5



SA342
1.5.5 beta



Spitfire IX
1.5.5 beta



Su-25T
1.5.5



TF-51D
1.5.5



UH-1H
1.5.5