



crestonWood
Furniture and Shop Design

SHOP-MADE MORTISING JIG PLANS



By Dan Phalen

January 2012

Shop-Made Mortising Jig Plans.

Copyright © 2012 by Daniel Phalen.

Published by Creston Hall Publishing Company, Scappoose, Oregon. All rights reserved.

No part of this document may be reproduced in any form or by electronic or mechanical means including information storage and retrieval systems without the written permission of the author.

Completed Mortising Jig

Here's what we're trying to build. The components are all rectangular, small, easy to fabricate. Anyone with a decent saw, a square, a drill press and a router can construct this jig in a weekend. And that includes coffee breaks.

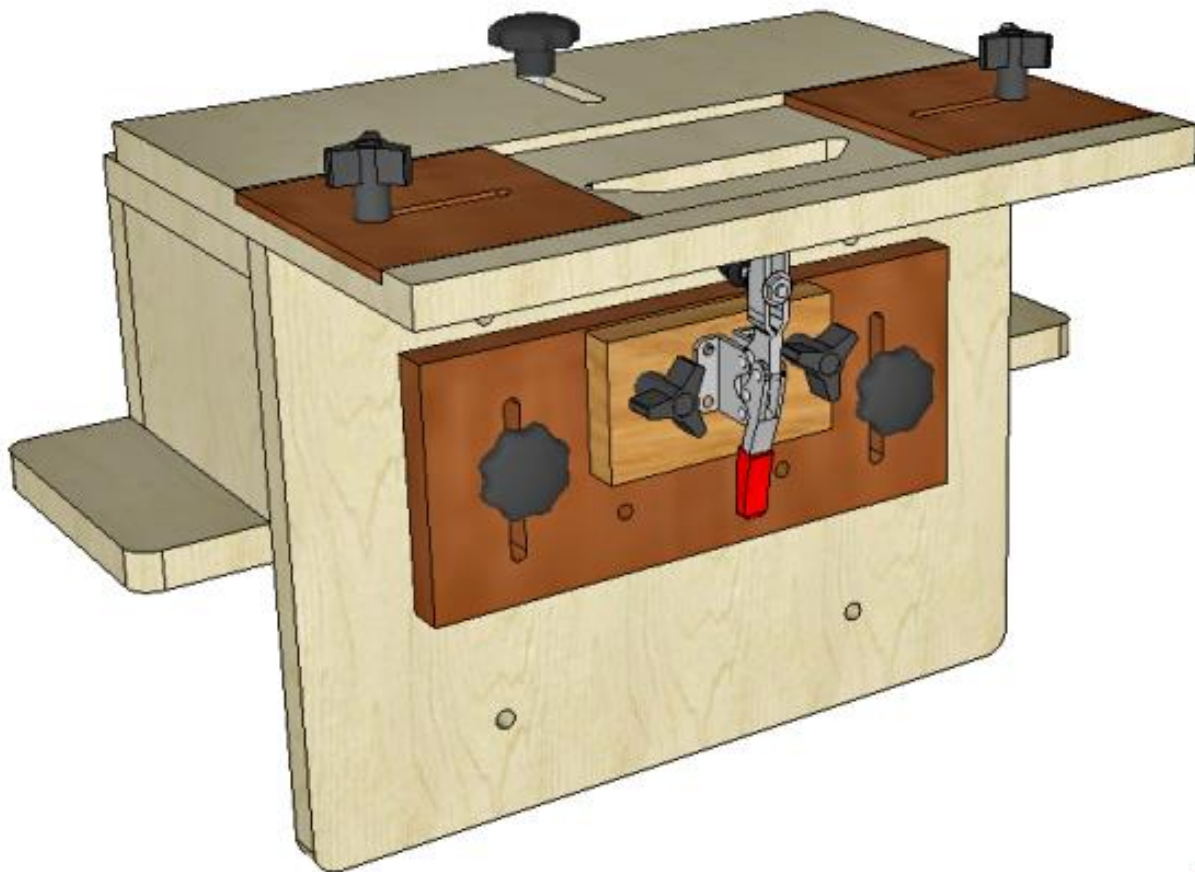

SET UP FOR USE

Shove the workpiece up against the underside of the Table by pushing the Fence Plate upward. Tighten but don't lock the Fence Plate knobs. Slide the Table forward and back until the window is centered over your mortise centerline. When the adjustments are complete, tighten the Table knob, tighten the Fence Plate knobs, and secure the workpiece with the toggle clamp (not shown).

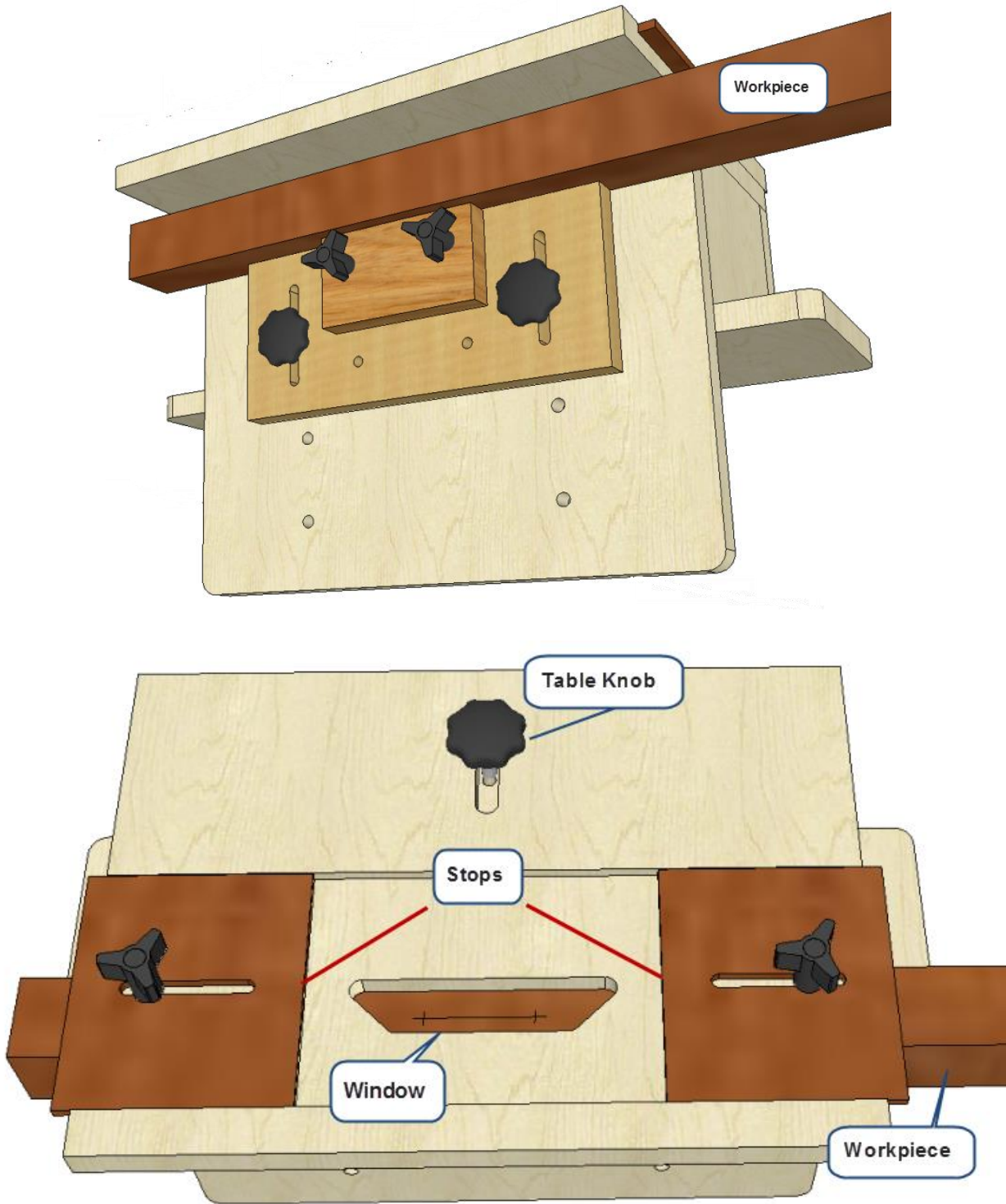

MATERIALS LIST

Nominal Dimensions	Quantity/Length	Part of Project
3/4" Birch Plywood	1 pc. 2ft. x 2 ft	Body, table and fence front
1/4" Hardboard	1 pc 12 in. x 6 in.	Stops
3/4" Medium Density Fiberboard	2 pcs. – shop scrap	Fence & clamp block
5-Star jig knobs	3 ea. 5/16" – 18 x 2"	Table, fence
3-Star jig knobs	4 ea. 1/4" – 20 x 1 1/4"	Stops, clamp block
Toggle clamp	1 Quck-set post/handle	Clamp block

*NOTE: The best plywood for this purpose is a 9-ply material.

BODY

Build the jig body from $\frac{3}{4}$ " shop ply or MDF. Drill and fasten all parts with #8 x $1\frac{1}{2}$ " wood screws.

Attach runners 3 inches from either end of the top, flush against the rear edge.

Drill a $\frac{5}{16}$ " hole in the top, centered $2\frac{1}{4}$ " from rear edge and 8" from either end. Countersink from the bottom and insert a $\frac{5}{16}$ " – 18 T-nut.

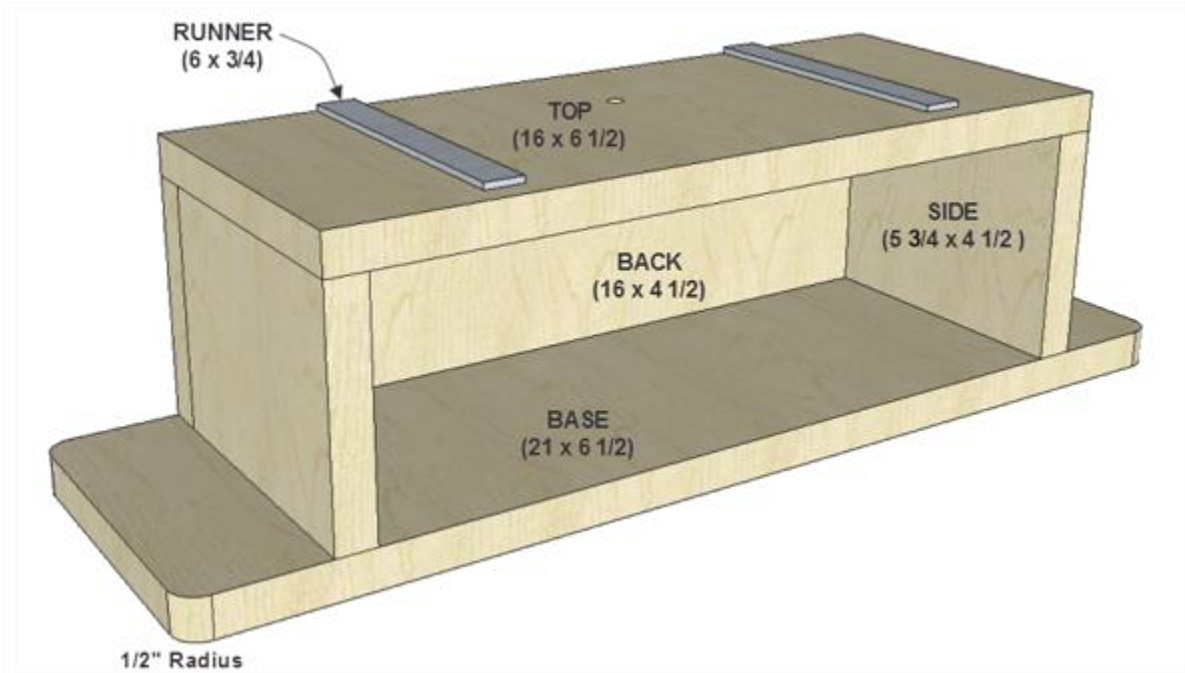

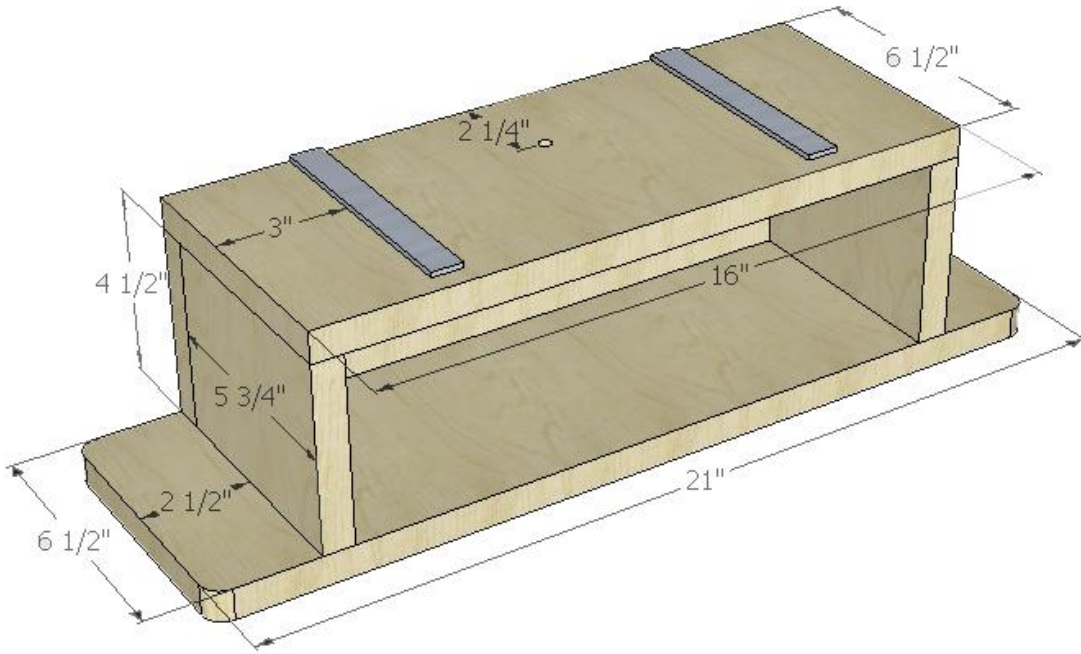

FENCE ASSEMBLY

The fence assembly is comprised of the Fence, the Fence Plate, the Clamp Block, and connecting 5/16" star knobs. Fasten a 5/16" T-nut to the back of each Fence hole and the back of each Fence Plate hole.

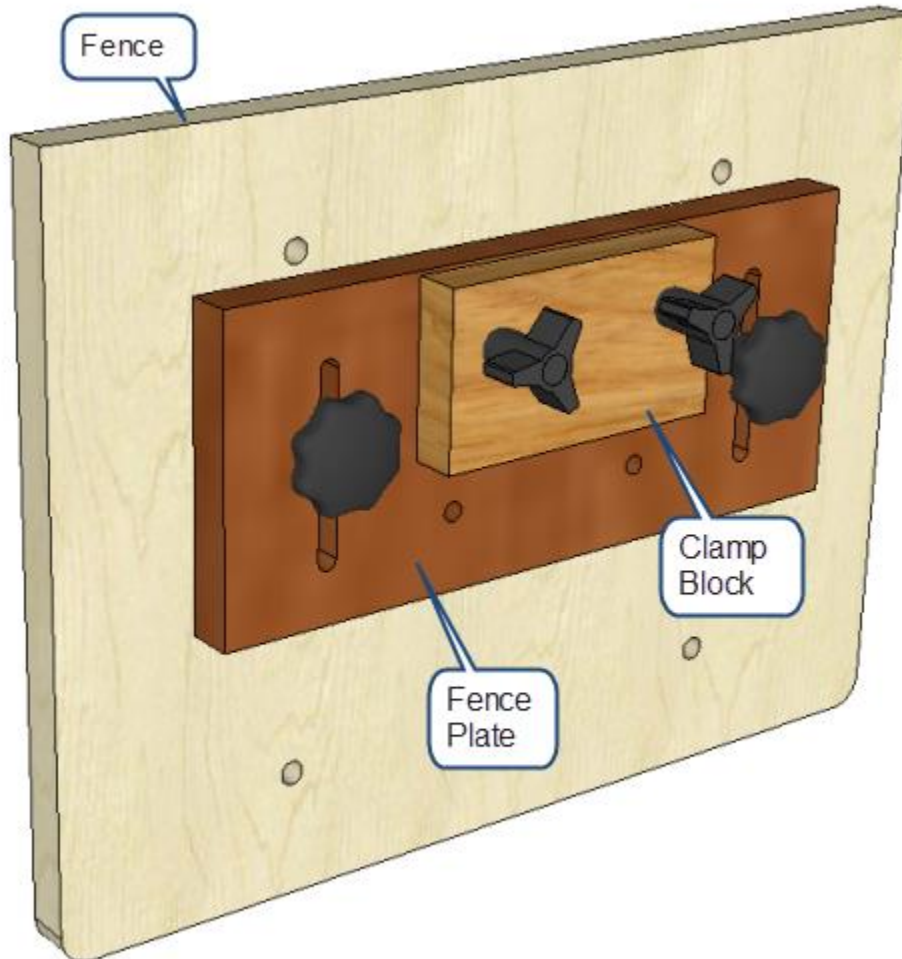

Mount a toggle clamp to the Clamp Block as shown to secure the workpiece against the Fence .



FENCE FABRICATION

Drill $3/8$ " holes into the Fence four (4) inches from either side, at the vertical intervals shown below. To make sure each T-nut face is flush with the back surface, countersink the back of each hole $1/8$ " or so.

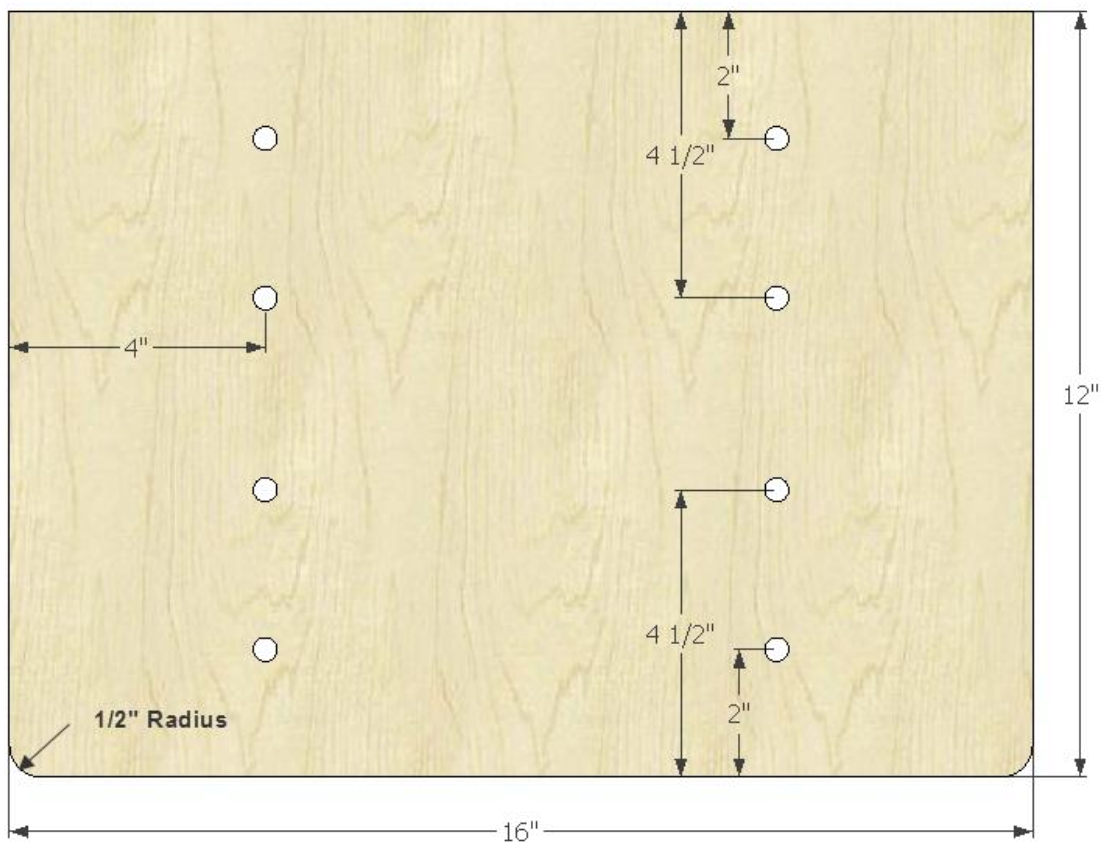
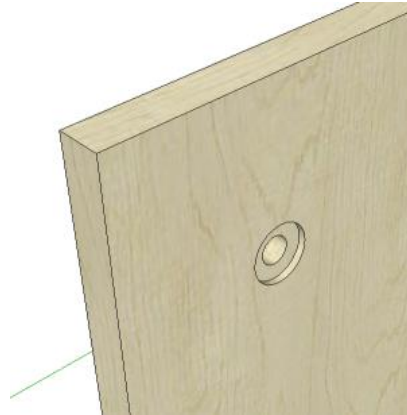

Attach the Fence to the body top, sides and base with #8 x 1 1/2" wood screws. Drill and countersink to make Front face smooth for sliding the workpiece into place beneath the table.

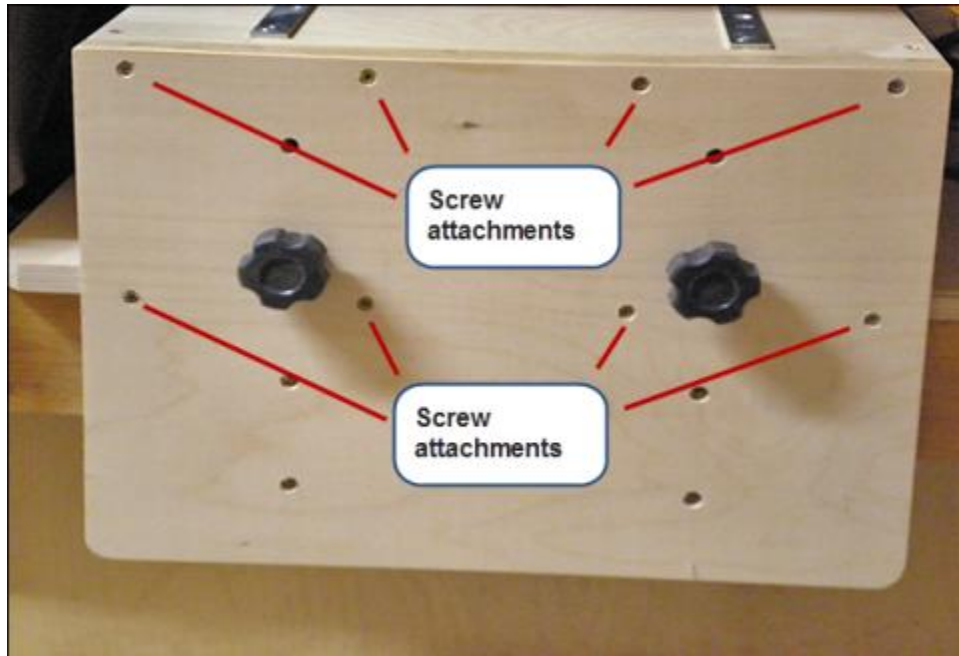

FENCE PLATE

The slots for attaching the Fence Plate to the Fence with star knobs must align with the holes in the Fence itself. Use the dimensions below as a guideline. It's a good idea to test the alignment first with a piece of scrap.

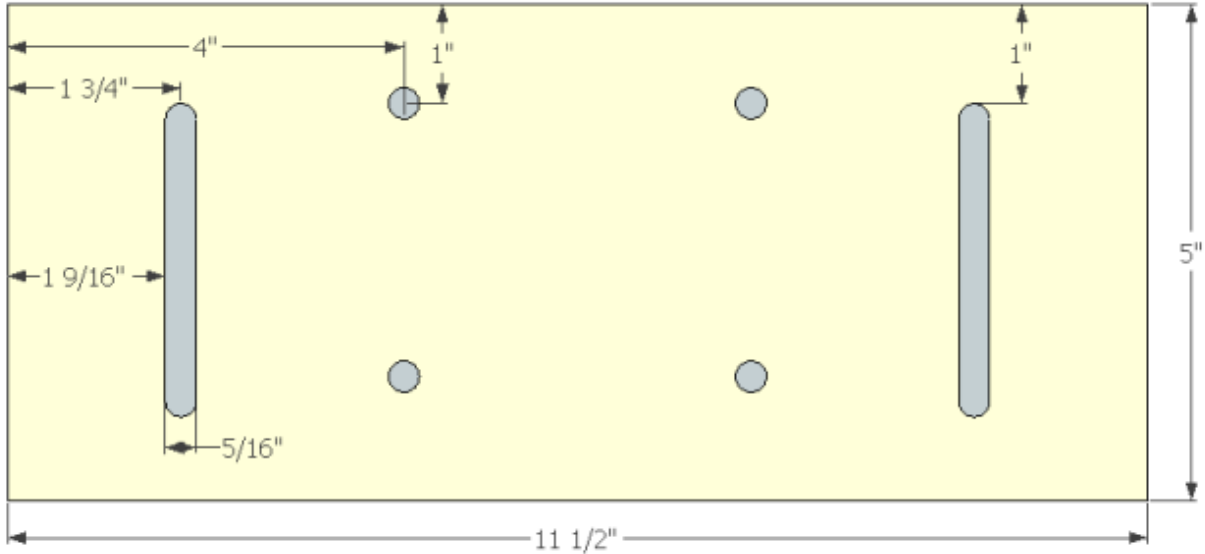

CLAMP BLOCK

The same applies to the Clamp Block. To align the Clamp Block holes with the corresponding holes in the Fence Plate, stack the two pieces, mark and align their width centers, then clamp and drill a 3/8" hole once through both pieces.

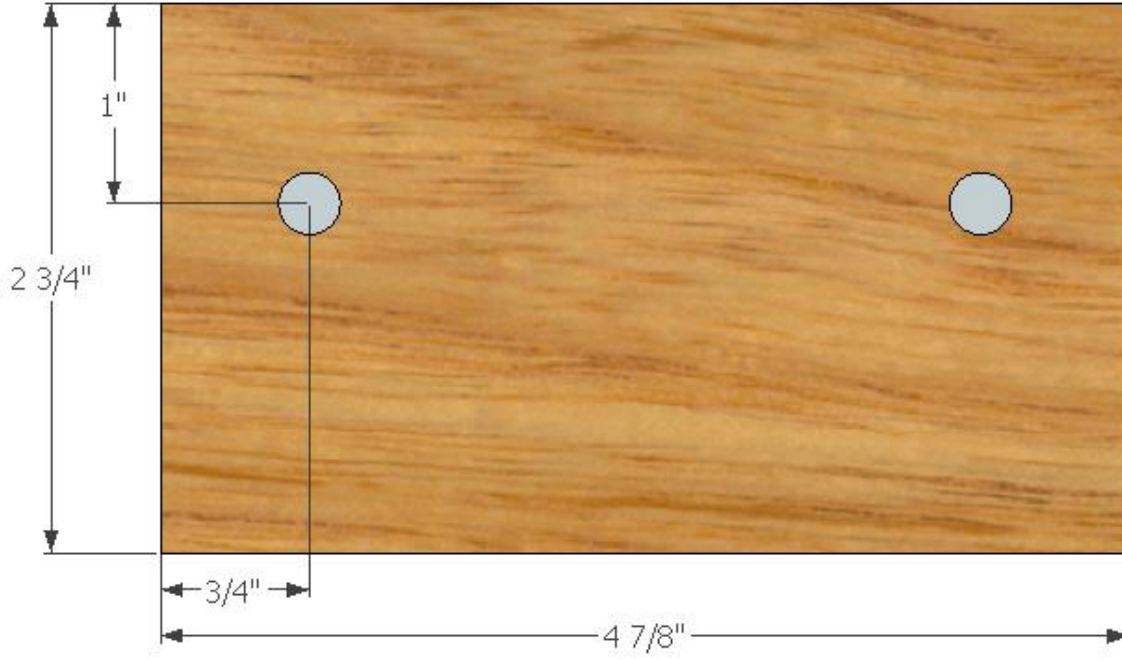
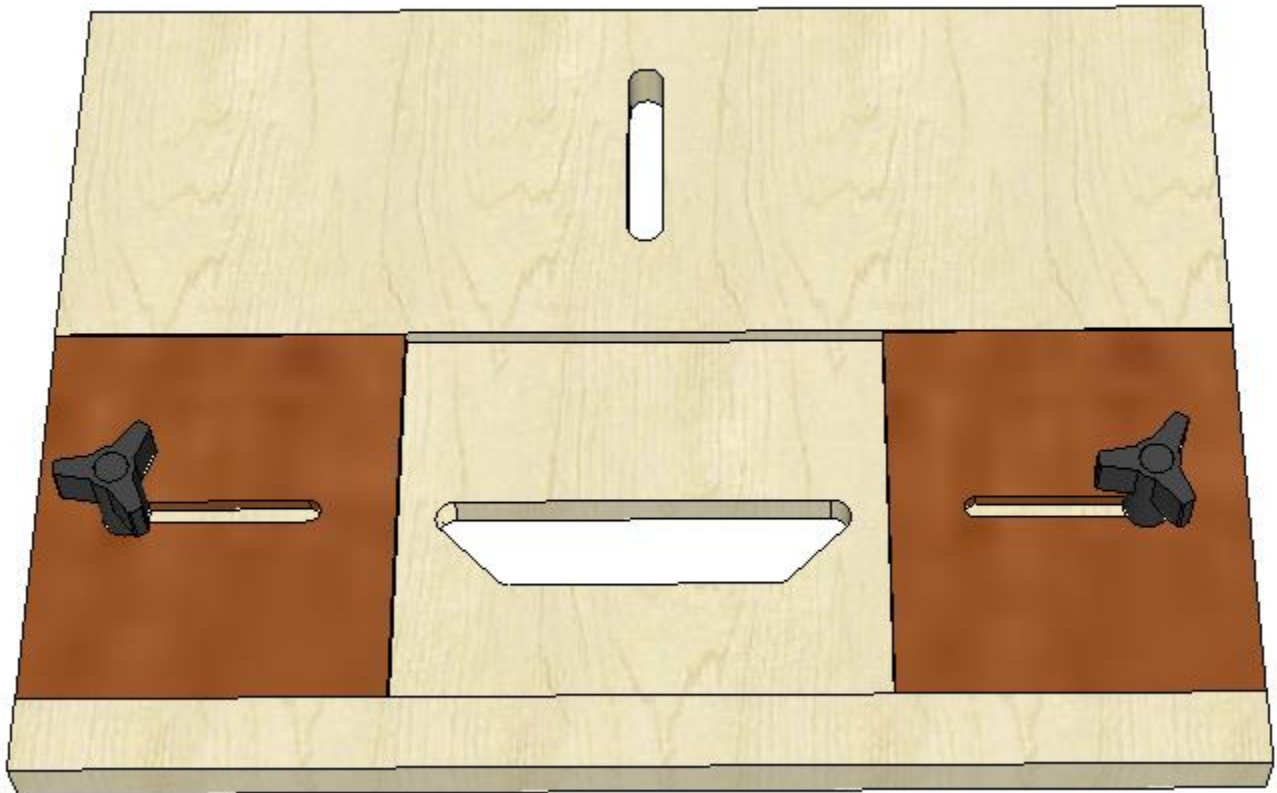

TABLE ASSEMBLY

The table assembly includes the table top and two stops secured by three-star knobs on top and $\frac{1}{4}$ " – 12 T-nuts countersunk in the bottom.



Cut the wide dado for the stops using a router or a table saw and taking multiple passes. Unfortunately, this may make an ugly surface as you scratch through the plies (see my photos) but the jig will still work.

Or use the “sandwich” approach.

1. Make your base of $\frac{1}{2}$ " plywood or MDF.
2. Cut the window in the base.
3. Measure and cut two pieces of $\frac{1}{4}$ " hardboard or hard ply for the front and back, $5\frac{1}{2}$ " x 16" and 1" x 16".
4. Cut your stops from $\frac{1}{4}$ " hardboard.
5. Glue the $\frac{1}{4}$ " top pieces into place using the pre-made stops as guides.
6. Drill for slot and star knob holes.

NOTE: Optionally, you can round the front corners with a $\frac{1}{2}$ " radius (see next page).

STOP DIMENSIONS

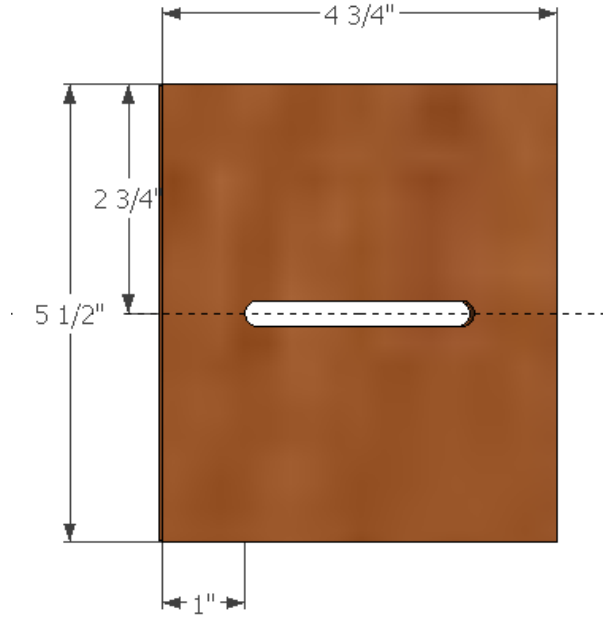

TOP DIMENSIONS

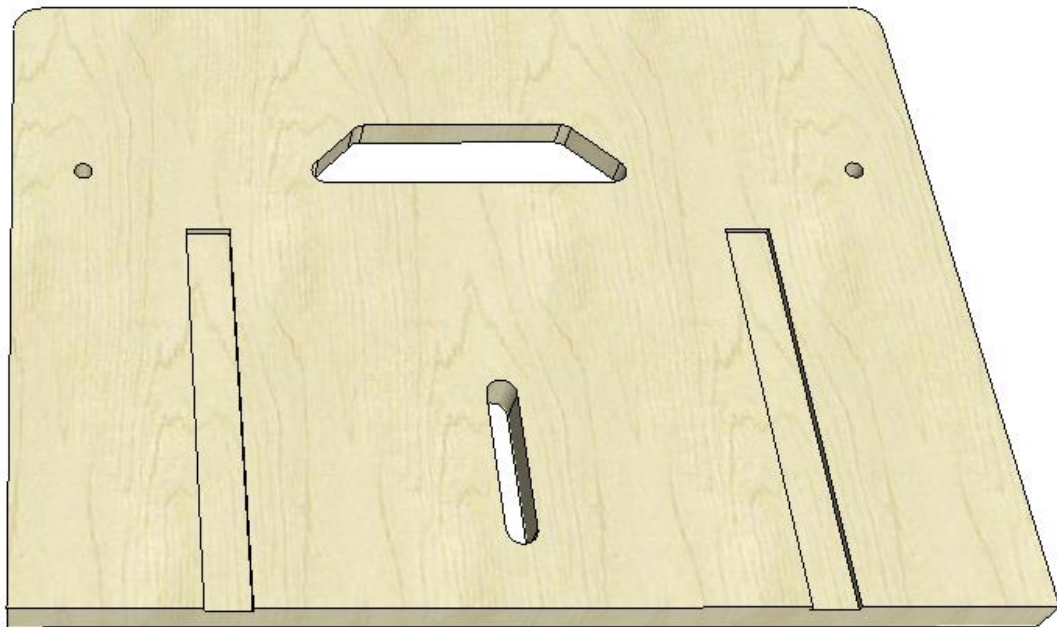
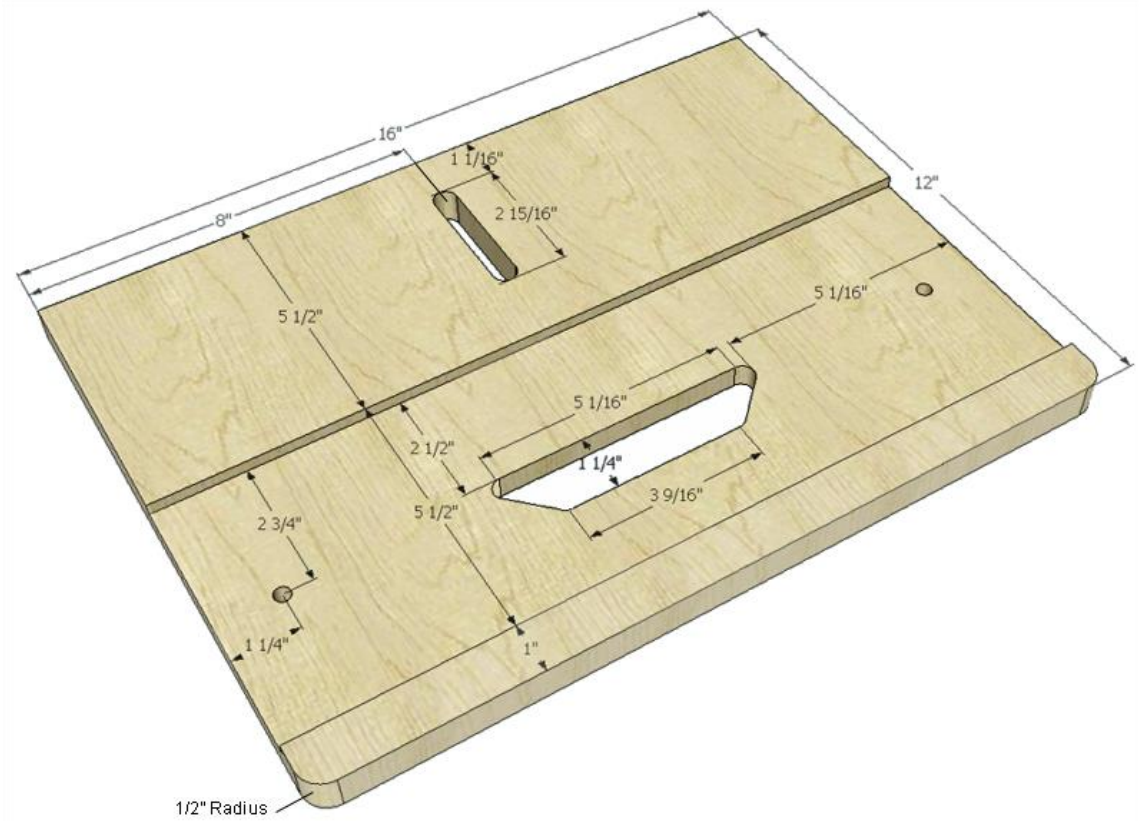

FINISHED APPEARANCE

With the star knobs and toggle clamp attached, this mortising jig is ready for service on any bench top or work table.

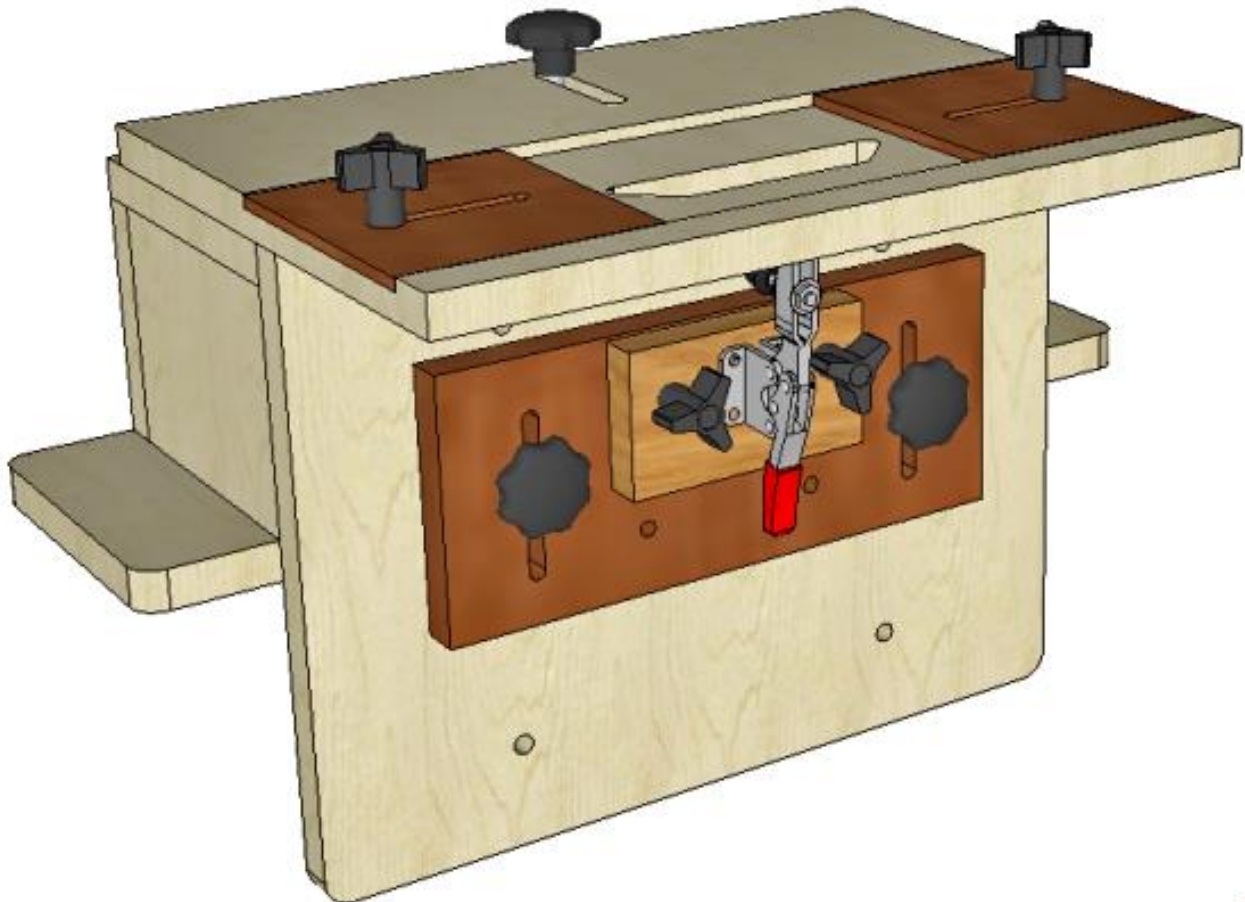

THAT'S IT!

This completes the plan drawings for my Shop-Built Mortising Jig. Please enjoy and let me hear from you about your success with it.

DAN PHALEN
CRESTON WOOD
SCAPPOOSE, OREGON, USA
woodbutcher@crestonwood.com

