

Save This Manual
For Future Reference

SEARS

*owners
manual*

**MODEL NO.
113.298720**

**SAW WITH LEGS
TWO CAST IRON
TABLE EXTENSIONS
MOTOR AND
QUICK RELEASE
RIP FENCE**

Serial
Number _____

Model and serial
number may be found
at the left-hand side
of the base.

You should record both
model and serial number
in a safe place for
future use.

CAUTION:

**Read GENERAL
and ADDITIONAL
SAFETY
INSTRUCTIONS
carefully**



CRAFTSMAN

10-INCH TABLE SAW

- *assembly*
- *operating*
- *repair parts*

Sold by SEARS, ROEBUCK AND CO., Chicago, IL. 60684 U.S.A.

FULL ONE YEAR WARRANTY ON CRAFTSMAN TABLE SAW

If within one year from the date of purchase, this Craftsman Table Saw fails due to a defect in material or workmanship, Sears will repair it, free of charge. This warranty applies only while this product is in use in the United States.

WARRANTY SERVICE IS AVAILABLE BY SIMPLY CONTACTING THE NEAREST SEARS SERVICE CENTER/DEPARTMENT THROUGHOUT THE UNITED STATES.

This warranty gives you specific legal rights, and you may also have other rights which vary from state to state.

SEARS, ROEBUCK AND CO., Dept. 698/731A, Sears Tower, Chicago, IL 60684

SAFETY INSTRUCTIONS FOR TABLE SAW

Safety is a combination of common sense, staying alert and knowing how your table saw works. Read this manual to understand this saw.

BEFORE USING THE SAW:

WARNING: TO AVOID MISTAKES THAT COULD CAUSE SERIOUS, PERMANENT INJURY, DO NOT PLUG THE SAW IN UNTIL THE FOLLOWING STEPS HAVE BEEN SATISFACTORILY COMPLETED.

1. Assembly and alignment (See pages 9 - 21).
2. Learn the use and function of the ON-OFF switch, guard, spreader, anti-kickback device, miter gauge, fence, table insert and blade elevation and bevel controls. (See page 22)
3. Review and understanding of all safety instructions and operating procedures in this manual.
4. Review of the maintenance methods for this saw. (See page 41)

Read the following DANGER label found on the front of the saw:

DANGER FOR YOUR OWN SAFETY:	
READ AND UNDERSTAND OWNERS MANUAL BEFORE OPERATING MACHINE.	
1. WEAR SAFETY GOGGLES.	5. KNOW HOW TO AVOID "KICKBACKS".
2. USE SAWBLADE GUARD FOR "THRU SAWING".	6. DO NOT PERFORM OPERATIONS "FREEHAND".
3. KEEP HANDS OUT OF PATH OF SAWBLADE.	7. NEVER REACH AROUND OR OVER SAWBLADE.
4. USE A "PUSH STICK" WHEN REQUIRED.	
WARNING: USE 120 VOLT, 15 AMP BRANCH CIRCUIT AND USE 15 AMP TIME DELAY FUSE.	

WHEN INSTALLING OR MOVING THE SAW:

1. AVOID DANGEROUS ENVIRONMENT. Use the saw in a dry place protected from rain. Keep work area well lighted.
2. To avoid injury from unexpected saw movement:
 - a. Put the saw on a firm level surface where there is plenty of room for handling and properly supporting the workpiece.
 - b. Support the saw so the table is level and the saw does not rock.
 - c. Bolt the saw to the floor if it tends to slip, walk, or slide during normal use.
 - d. When using table extensions over 24" wide on any side of the saw, bolt the saw to the floor or prop up the outer end of the extension from the floor to keep the saw from tipping.
3. Put the saw where neither operators or bystanders must stand in line with the saw blade.
4. GROUND THE SAW - This saw has an approved 3-conductor cord and a 3-prong grounding type plug. The plug fits grounding type outlets design-

ed for 120 volt 15 amp circuits. The green conductor in the cord is the grounding wire. To avoid electrocution, NEVER connect the green wire to a live terminal.

5. To avoid injury from electrical shock, make sure your fingers do not touch the plug's metal prongs when plugging in or unplugging the saw.
6. To avoid back injury, get help or use recommended casters when you need to move the saw. Always get help if you need to lift the saw. Hold the saw close to your body. Bend your knees so you can lift with your legs, not your back.
7. NEVER STAND ON TOOL. Serious injury could occur if the tool tips or you accidentally hit the cutting tool. Do not store anything above or near the tool where anyone might stand on the tool to reach them.

BEFORE EACH USE:

1. Inspect your saw.
 - a. To avoid injury from accidental starting, unplug the saw, turn the switch off and remove the switch key before raising or removing the guard, changing the cutting tool, changing the setup or adjusting anything.
 - b. Check for alignment of moving parts, binding of moving parts, breakage of parts, mounting, and any other conditions that may affect the way it works. If any part is missing, bent, or broken in any way, or any electrical parts don't work properly, turn the saw off and unplug the saw.
 - c. Replace damaged, missing, or failed parts before using the saw again.
 - d. Use the sawblade guard, spreader, and anti-kickback pawls for any thru-sawing (whenever the blade comes through the top of the workpiece). Make sure the pawls work properly. Make sure the spreader is in line with the sawblade.
 - e. REMOVE ADJUSTING KEYS AND WRENCHES. Form habit of checking for and removing keys and adjusting wrenches from tool before turning it on.
 - f. To avoid injury from jams, slips or thrown pieces (kickback and throwback):
 1. USE ONLY RECOMMENDED ACCESSORIES. Follow the instructions that come with the accessories. Consult the owner's manual for recommended accessories. The use of improper accessories may cause risk of injury to persons.

2. Choose the right blade or cutting accessory for the material and the type of cutting you plan to do.
3. Never use grinding wheels, abrasive cut-off wheels, friction wheels (metal slitting blades) wire wheels or buffing wheel. They can fly apart explosively.
4. Choose and inspect your cutting tool carefully.
 - a. To avoid cutting tool failure and thrown shrapnel (broken pieces of blade), use only 10" or smaller blades or other cutting tools marked for speeds of 3450 rpm or higher.
 - b. Always use unbroken, balanced blades designed to fit this saw's 5/8" arbor.
 - c. When thru-sawing, (making cuts where the blade comes through the workpiece top) always use a 10 inch diameter blade. This keeps the spreader in closest to the blade.
 - d. Do not overtighten arbor nut. Use arbor wrenches to "snug" it securely.
 - e. Use only sharp blades with properly set teeth. Consult a professional blade sharpener when in doubt.
 - f. Keep blades clean of gum and resin.
5. Adjust table inserts flush with the table top. NEVER use the saw without the proper insert.
6. Make sure all clamps and locks are tight and no parts have any excessive play.

2. KEEP WORK AREA CLEAN

- a. Cluttered areas and benches invite accidents. Floor must not be slippery from wax or sawdust.
- b. To avoid burns or other fire damage, never use the saw near flammable liquids, vapors or gases.

Plan ahead to protect your eyes, hands, face, ears.

- a. To avoid injury, don't do layout, assembly, or setup work on the table while the blade is spinning. It could cut or throw anything hitting the blade.

AVOID ACCIDENTAL STARTING - Make sure switch is "OFF" before plugging saw in.

Plan your work

1. **USE THE RIGHT TOOL** - Don't force tool or attachment to do a job it was not designed for.
2. **Dress for safety:**
 - **Do not wear** loose clothing, gloves, neckties or jewelry (rings, wrist watches). They can get caught and draw you into moving parts.
 - Wear nonslip footwear.
 - Tie back long hair.
 - Roll long sleeves above the elbow.
 - Noise levels vary widely. To avoid possible hearing damage, wear ear plugs or muffs when using saw for long periods of time.

- Any power saw can throw foreign objects into the eyes. This can cause permanent eye damage. Wear safety **goggles (not glasses)** that comply with ANSI Z87.1 (shown on package). Everyday eyeglasses have only impact resistant lenses. They are not safety glasses. Safety goggles are available at Sears retail catalog stores. Glasses or goggles not in compliance with ANSI Z87.1 could seriously hurt you when they break.



- For dusty operations, wear a dust mask along with the safety goggles.
3. Inspect your workpiece. Make sure there are no nails or foreign objects in the part of the workpiece to be cut.
 4. Plan your cut to avoid **KICKBACKS** and **THROWBACKS** - when a part or all of the workpiece binds on the blade and is thrown violently back toward the front of the saw:
 - **Never cut FREEHAND:** Always use either a rip fence, miter gauge or fixture to position and guide the work, so it won't twist, bind on the blade and kickback.
 - Make sure there's no debris between the workpiece and its supports.
 - When cutting **irregularly shaped workpieces**, plan your work so it will not slip and pinch the blade:
 - A piece of molding, for example, must lie flat or be held by a fixture or jig that will not let it twist, rock or slip while being cut. Use jigs, fixtures where needed to prevent workpiece shifting.
 - Use a different, better suited type of tool for work that can't be made stable.
 - Use extra caution with large, very small or awkward workpieces:
 - Use extra supports (tables, saw horses, blocks, etc.) for any workpieces large enough to tip when not held down to the table top. **NEVER use another person** as a substitute for a table extension, or as additional support for a workpiece that is longer or wider than the basic saw table, or to help feed, support or pull the workpiece.
 - Never confine the piece being cut off. That is, the piece NOT against the fence, miter gauge or fixture. Never hold it, clamp it, touch it, or use length stops against it. It must be free to move. If confined, it could get wedged against the blade and cause a kickback or throwback.

- Never cut more than one workpiece at a time.
- Never turn your table saw "ON" before clearing everything except the workpiece and related support devices off the table.

Plan the way you will push the workpiece through.

- **NEVER pull the workpiece** through. Start and finish the cut from the front of the table saw.
- **NEVER put your fingers or hands in the path** of the sawblade or other cutting tool.
- **NEVER reach in back** of the cutting tool with either hand to hold down or support the workpiece, remove wood scraps, or for any other reason.
- Avoid hand positions where a sudden slip could cause fingers or hand to move into a sawblade or other cutting tool.
- **DON'T OVERREACH.** Always keep good footing and balance.
- Push the workpiece against the rotation of the blade. **NEVER** feed material into the cutting tool from the rear of the saw.
- Always push the workpiece all the way past the sawblade.
- As much as possible, keep your face and body to one side of the sawblade, out of line with a possible kickback or throwback.
- **NEVER** turn the saw "ON" before clearing the table of all tools, wood scraps, etc., except the workpiece and related feed or support devices for the cut planned.

WHENEVER SAW IS RUNNING

WARNING: DON'T LET FAMILIARITY (GAINED FROM FREQUENT USE OF YOUR TABLE SAW) CAUSE A CARELESS MISTAKE. ALWAYS REMEMBER THAT A CARELESS FRACTION OF A SECOND IS ENOUGH TO CAUSE A SEVERE INJURY.

1. Before actually cutting with the saw, watch it while it runs for a short while. If it makes an unfamiliar noise or vibrates a lot, stop immediately. Turn the saw off. Unplug the saw. Do not restart until finding and fixing the problem.
2. Make sure the top of the arbor or cutting tool turns toward the front of the saw.
3. Set the cutting tool as low as possible for the cut you're planning.
4. **KEEP CHILDREN AWAY.** All visitors should be kept a safe distance from work. Make sure bystanders are clear of the saw and workpiece.
5. Let the blade reach full speed before cutting.
6. **DON'T FORCE TOOL.** It will do the job better and safer at its designed rate. Feed the workpiece into the blade only fast enough to let it cut without bogging down or binding.
7. Before freeing any jammed material:
 - a. Turn switch "OFF".
 - b. Unplug the saw.

- c. Wait for all moving parts to stop.
 - d. Check blade, spreader and fence for proper alignment before starting, again.
8. To avoid throwback of small, cut off pieces:
 - a. Use the guard assembly.
 - b. To remove pieces trapped inside the guard:
 1. Turn saw off.
 2. Remove switch key.
 3. Unplug saw.
 4. Wait for blade to stop before lifting the guard.

additional instructions for RIP TYPE CUTS

- **NEVER** use the miter gauge when ripping.
- Use a push stick whenever the fence is 2 to 6 inches from the blade. Use an auxiliary fence and push block whenever the fence must be within 2 inches of the blade. (See "Basic Saw Operation Using The Rip Fence" section.)
- Never rip anything shorter than 10" long.
- When using a push stick or push block, the trailing end of the board must be square. A push stick or block against an uneven end could slip off or push the work away from the fence.
- A **FEATHERBOARD** can help guide the workpiece. See **BASIC SAW OPERATION - USING THE RIP FENCE.** **Always** use featherboards for any non-thru rip type cuts.

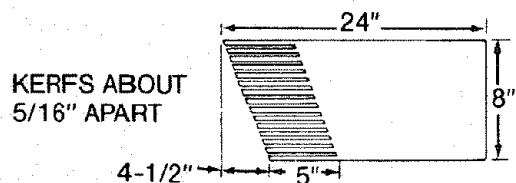

Before Starting

- To avoid kickbacks and slips into the blade, make sure the rip fence is parallel to the sawblade.
- Check the antikickback pawls. (See **BASIC SAW OPERATION - USING THE RIP FENCE.**) The pawls must stop a kickback once it has started. Replace or sharpen antikickback pawls when points become dull.
- Plastic and composition (like hardboard) materials may be cut on your saw. However, since these are usually quite hard and slippery, the antikickback pawls may not stop a kickback. Therefore, be especially careful in your set-up and cutting procedures.

While cutting

- To avoid kickbacks and slips into the blade, always push forward on the section of the workpiece between the saw blade and the rip fence. Never push forward on the piece being cut off.

additional instructions for CROSS CUT TYPE CUTS

Before starting

- NEVER use the rip fence when crosscutting.
- An auxiliary wood facing attached to the miter gauge can help prevent workpiece twisting and throwbacks. Attach it to the holes provided. Make the facing long enough and big enough to support your work. Make sure, however, it will not interfere with the sawblade guard.
- Use jigs or fixtures to help hold any piece too small to extend across the full length of the miter gauge face during the cut. This lets you properly hold the miter gauge and workpiece and helps keep your hands away from the blade.

While cutting

- To avoid blade contact, always hold the miter gauge as shown in the BASIC SAW OPERATIONS - USING THE MITER GAUGE.

BEFORE LEAVING THE SAW

1. Turn the saw off.
2. Wait for blade to stop spinning.
3. Make workshop child-proof. Lock the shop. Disconnect master switches. Remove the yellow switch key. Store it away from children and others not qualified to use the tool.
4. Unplug the saw.

GLOSSARY OF TERMS FOR WOODWORKING

Anti-Kickback Pawls (AKB)

Device which, when properly maintained, is designed to stop the workpiece from being kicked back at the operator during ripping operations.

Arbor

The shaft on which a cutting tool is mounted.

Crosscut

A cutting or shaping operation made across the width of the workpiece.

Dado

A non-through cut which produces a square sided notch or trough in the workpiece.

Featherboard

A device which can help guide workpieces during rip type operations.

Freehand

Performing a cut without using a fence, miter gauge, fixture, hold down or other proper device to keep the workpiece from twisting during the cut.

Gum

A sticky, sap based residue from wood products.

Heel

Misalignment of the blade.

Kerf

The amount of material removed by the blade in a through cut or the slot produced by the blade in a non-through or partial cut.

Kickback

An uncontrolled grabbing and throwing of the workpiece back toward the front of the saw during a rip type operation.

Leading End

The end of the workpiece which, during a rip type operation, is pushed into the cutting tool first.

Molding

A non-through cut which produces a special shape in the workpiece used for joining or decoration.

Push Stick

A device used to feed the workpiece through the saw during narrow ripping type operations and help keep the operator's hands well away from the blade.

Push Block

A device used for ripping type operations too narrow to allow use of a push stick.

Rabbet

A notch in the edge of a workpiece.

Resin

A sticky, sap base substance that has hardened.

Ripping

A cutting operation along the length of the workpiece.

Revolutions Per Minute (RPM)

The number of turns completed by a spinning object in one minute.

Sawblade Path

The area of the workpiece or table top directly in line with the part of the workpiece which will be, or has been, cut by the blade.

Set

The distance that the tip of the sawblade tooth is bent (or set) outward from the face of the blade.

Throw-Back

Throwing of pieces in a manner similar to a kickback.

Thru-Sawing

Any cutting operation where the blade extends completely through the thickness of the workpiece.

Trailing End

The workpiece end last cut by the blade in a ripping operation.

Workpiece

The item on which the cutting operation is being done. The surfaces of a workpiece are commonly referred to as faces, ends, and edges.

MOTOR SPECIFICATIONS AND ELECTRICAL REQUIREMENTS

This saw is designed to use a 3450 RPM motor only. Do not use any motor that runs faster than 3450 RPM. It is wired for operation on 110-120 volts, 60 Hz., Alternating current. **IT MUST NOT BE CONVERTED TO OPERATE ON 230 VOLTS.**

The Black and Red motor leads are connected to quick connect tabs "A" and "B" on terminal board.

WARNING: Do not change any of these connections with current on.

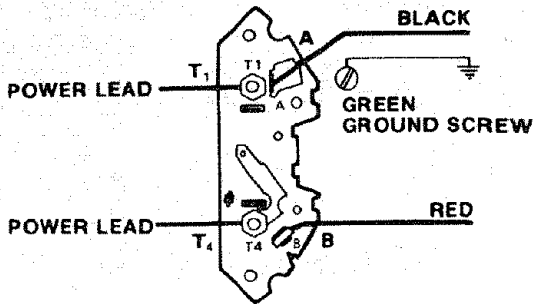

CAUTION: Do not use blower or washing machine motors or any motor with an automatic reset overload protector as their use may be hazardous. For replacement motor refer to parts list in this manual.

CONNECTING TO POWER SOURCE OUTLET

This saw must be grounded while in use to protect the operator from electrical shock.

If power cord is worn or cut, or damaged in any way, have it replaced immediately.

If your saw is for use on less than 150 volts it has a plug that looks like below.

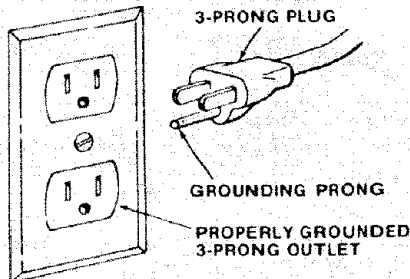

Plug power cord of fully assembled saw into 110-120V properly grounded type outlet protected by a 15-amp. time delay or Circuit-Saver fuse or circuit breaker.

IF YOU ARE NOT SURE THAT YOUR OUTLET IS PROPERLY GROUNDED, HAVE IT CHECKED BY A QUALIFIED ELECTRICIAN.

WARNING: DO NOT PERMIT FINGERS TO TOUCH THE TERMINALS OF PLUG WHEN INSTALLING OR REMOVING THE PLUG TO OR FROM THE OUTLET.

WARNING: IF NOT PROPERLY GROUNDED THIS POWER TOOL CAN INCUR THE POTENTIAL HAZARD OF ELECTRICAL SHOCK PARTICULARLY WHEN USED IN DAMP LOCATIONS, IN PROXIMITY TO PLUMBING, OR OUT OF DOORS. IF AN ELECTRICAL SHOCK OCCURS THERE IS THE POTENTIAL OF A SECONDARY HAZARD SUCH AS YOUR HANDS CONTACTING THE SAWBLADE.

This saw is equipped with a 3-conductor cord and grounding type plug which has a grounding prong, approved by Underwriters' Laboratories and the Canadian Standards Association. The ground

conductor has a green lug and is attached to the tool housing at one end and to the ground prong in the attachment plug at the other end.

This plug requires a mating 3-conductor grounded type outlet as shown.

If the outlet you are planning to use for this saw is of the two prong type **DO NOT REMOVE OR ALTER THE GROUNDING PRONG IN ANY MANNER.** Use an adapter as shown and always connect the grounding lug to a known ground.

It is recommended that you have a qualified electrician replace the TWO prong outlet with a properly grounded THREE prong outlet.

A temporary adapter as shown below is available for connecting plugs to 2-prong receptacles. The green grounding lug extending from the adapter must be connected to a permanent ground such as to a properly grounded outlet box.

A temporary adapter as illustrated is available for connecting plugs to 2-prong receptacles. The temporary adapter should be used only until a properly grounded outlet can be installed by a qualified electrician.

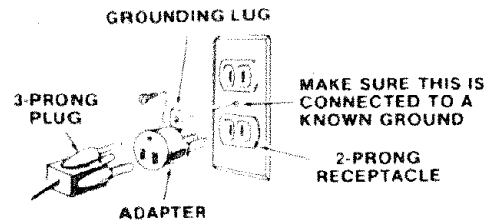

WARNING: THE GREEN GROUNDING LUG EXTENDING FROM THE ADAPTER MUST BE CONNECTED TO A PERMANENT GROUND SUCH AS TO A PROPERLY GROUNDED OUTLET BOX. NOT ALL OUTLET BOXES ARE PROPERLY GROUNDED.

If you are not sure that your outlet box is properly grounded, have it checked by a qualified electrician.

NOTE: The adapter illustrated is for use only if you already have a properly grounded 2-prong receptacle.

The use of any extension cord will cause some loss of power. To keep this to a minimum and to prevent over-heating and motor burn-out, use the table below to determine the minimum wire size (A.W.G.) extension cord. Use only 3 wire extension cords which have 3 prong grounding type plugs and 3-pole receptacles which will accept the plug on the saw.

1 H.P. MOTOR 110-120V	
Extension Cord Length	Wire Size A.W.G.
0-25 Ft.	16
26-50 Ft.	14
51-100 Ft.	12

CHECK MOTOR ROTATION

WARNING: FOR YOUR OWN SAFETY, MAKE SURE PLUG IS NOT CONNECTED TO POWER SOURCE OUTLET WHEN CHANGING MOTOR ROTATION.

The motor must rotate **CLOCKWISE** when viewed from the shaft end to which you will mount the pulley. (See page 18.) If it does not, change the direction according to the instructions furnished with the motor.

CONTENTS

<p>WARRANTY 2</p> <p>SAFETY INSTRUCTIONS FOR TABLE SAWS 2</p> <p style="padding-left: 20px;">Rip Type Cuts 4</p> <p style="padding-left: 20px;">Cross Cut Type Cuts 5</p> <p>GLOSSARY OF WOODWORKING TERMS 5</p> <p>MOTOR SPECIFICATIONS AND ELECTRICAL REQUIREMENTS 6</p> <p>UNPACKING AND CHECKING CONTENTS 7</p> <p style="padding-left: 20px;">Tools Needed 7</p> <p style="padding-left: 20px;">List of Loose Parts 8</p> <p>ASSEMBLY 9</p> <p style="padding-left: 20px;">Installing Handwheels 9</p> <p style="padding-left: 20px;">Checking Table Insert 9</p> <p style="padding-left: 20px;">Checking Blade Squareness to Table 9</p> <p style="padding-left: 20px;">Assembling Steel Legs 10</p> <p style="padding-left: 20px;">Mounting Saw 10</p> <p style="padding-left: 20px;">Attaching Table Extensions 11</p> <p style="padding-left: 20px;">Mounting Switch 12</p> <p style="padding-left: 20px;">Installing Rip Fence Guide Bars 12</p> <p style="padding-left: 20px;">Aligning Rip Fence 14</p> <p style="padding-left: 20px;">Adjusting Rip Scale Pointer 16</p> <p style="padding-left: 20px;">Installing Blade Guard 16</p> <p style="padding-left: 20px;">Mounting the Motor 18</p> <p style="padding-left: 20px;">Installing Belt Guard 20</p> <p style="padding-left: 20px;">Plugging in Motor 21</p> <p>GETTING TO KNOW YOUR SAW 22</p> <p style="padding-left: 20px;">On-Off Switch 22</p> <p style="padding-left: 20px;">Elevation Handwheel 23</p> <p style="padding-left: 20px;">Tilt Handwheel 23</p> <p style="padding-left: 20px;">Tilt Lock Handle 23</p> <p style="padding-left: 20px;">Rip Fence 23</p> <p style="padding-left: 20px;">Miter Gauge 23</p> <p style="padding-left: 20px;">Blade Guard 23</p> <p style="padding-left: 20px;">Table Insert 23</p>	<p>Removing and Installing Sawblade 24</p> <p>Exact-I-Cut 24</p> <p>BASIC SAW OPERATION 25</p> <p style="padding-left: 20px;">Work Helpers 25</p> <p style="padding-left: 20px;">Safety Instructions for Basic Saw Operation 26</p> <p style="padding-left: 20px;">Using the Miter Gauge 29</p> <p style="padding-left: 40px;">Crosscutting 29</p> <p style="padding-left: 40px;">Repetitive Cutting 30</p> <p style="padding-left: 40px;">Miter Cutting 30</p> <p style="padding-left: 40px;">Bevel Crosscutting 31</p> <p style="padding-left: 40px;">Compound Miter Cutting 31</p> <p style="padding-left: 20px;">Using the Rip Fence 31</p> <p style="padding-left: 40px;">Ripping 32</p> <p style="padding-left: 40px;">Bevel Ripping 32</p> <p style="padding-left: 40px;">Using Featherboards for Thru-Sawing 32</p> <p style="padding-left: 40px;">Resawing 35</p> <p style="padding-left: 40px;">Cutting Panels 35</p> <p style="padding-left: 40px;">Using Featherboards for Non-Thru Sawing 35</p> <p style="padding-left: 40px;">Rabbeting 36</p> <p style="padding-left: 40px;">Ploughing and Molding 36</p> <p style="padding-left: 40px;">Dadoing 36</p> <p style="padding-left: 40px;">Molding Cutting 37</p> <p>ADJUSTMENTS 37</p> <p style="padding-left: 20px;">Miter Gauge 37</p> <p style="padding-left: 20px;">Heeling Adjustment or Parallelism of Sawblade to Miter Gauge Groove 38</p> <p style="padding-left: 20px;">Blade Tilt or Squareness of Blade to Table 39</p> <p style="padding-left: 20px;">Tilt Mechanism 41</p> <p>MAINTENANCE 41</p> <p>LUBRICATION 42</p> <p>RECOMMENDED ACCESSORIES 42</p> <p>TROUBLESHOOTING 43</p> <p>REPAIR PARTS 45</p>
---	--

UNPACKING AND CHECKING CONTENTS

TOOLS NEEDED



Separate all parts from packing materials and check each one with the illustration and the list of Loose Parts to make certain all items are accounted for, before discarding any packing material.

If any parts are missing, do not attempt to assemble the table saw, plug in the power cord or turn the switch on until the missing parts are obtained and are installed correctly.

Remove the protective oil that is applied to the table top and edges of the table. Use any ordinary household type grease and spot remover.

COMBINATION SQUARE MUST BE TRUE.

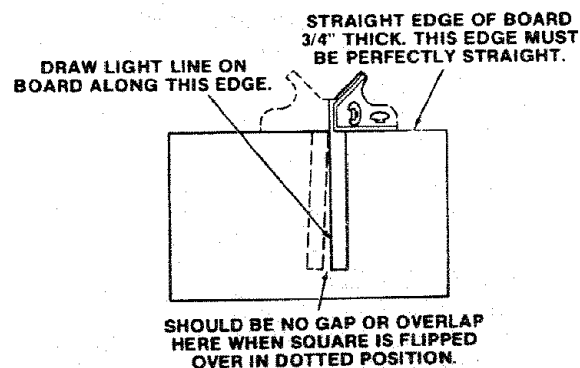

WARNING: TO AVOID FIRE OR HEALTH HAZARD, NEVER USE GASOLINE, NAPHTHA OR SIMILAR HIGHLY VOLATILE SOLVENTS.

Apply a coat of automobile wax to the table.

Wipe all parts thoroughly with a clean, dry cloth.

WARNING: FOR YOUR OWN SAFETY, NEVER CONNECT PLUG TO POWER SOURCE OUTLET UNTIL ALL ASSEMBLY STEPS ARE COMPLETE, AND YOU HAVE READ AND UNDERSTAND THE SAFETY AND OPERATIONAL INSTRUCTIONS.

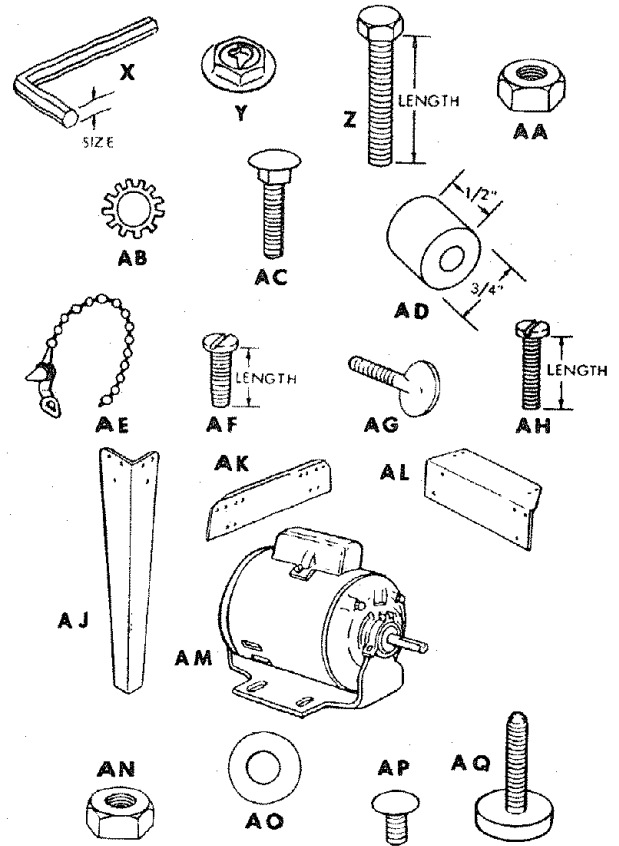
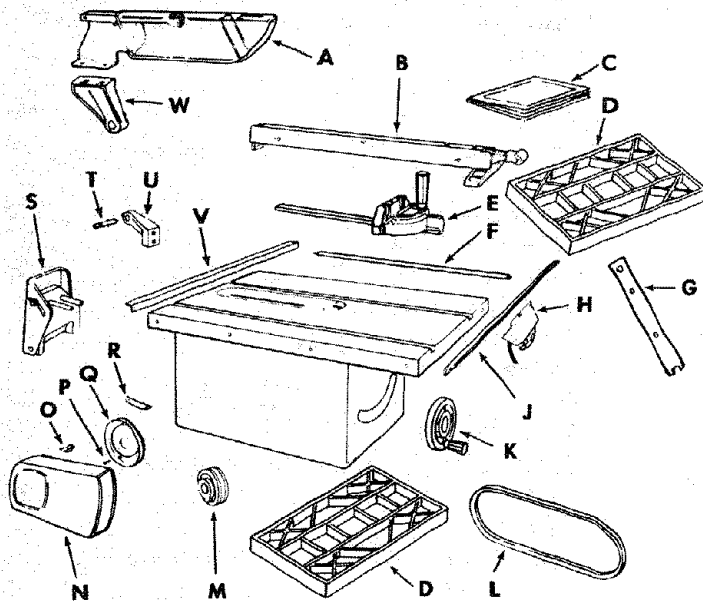

LIST OF LOOSE PARTS

Item	Part Name	Qty.
A	Blade Guard and Spreader	1
B	Rip Fence	1
C	Owners Manual	1
D	Cast Iron Table Extensions	2
E	Miter Gauge	1
F	Rip Fence Guide Bar Rod	1
J	Rip Fence Guide Bar with Rip Scale (Front)	1
S	Support, Motor Base	1
V	Rip Fence Guide Bar (Rear)	1
AJ	Leg	4
AK	Side Stiffener	2
AL	End Stiffener	2
AM	Motor	1
	Bag of Loose Parts	2
	Bag of Loose Parts (Containing the Following Items)	
H	Outlet, On/Off with Key	1
K	Handwheel	2
	Bag of Loose Parts	3
	Bag of Loose Parts (Containing the Following Items)	
N	Belt and Pulley Guard	1
O	Belt Guard Clip "S"	3
P	Screw, Pan Hd. 10-32 x 1/2" Long	3
Q	Support, Belt Guard	1
R	Belt Guard Support Bracket	1
	Bag of Loose Parts No. 62750 (Containing the Following Items)	
G	Wrench, Arbor	1
L	Belt, "V" 1/2" x 41"	1
M	Pulley, 1/2" dia. with 5/8" Bore	1
T	Spreader, Rod	1
U	Blade Guard Support w/Screw	1
W	Spreader Support	1
	Bag of Loose Parts No. 62751	1
	Bag of Loose Parts No. 507780 (Containing the Following Items)	
Z	Screw, Hex Hd. 5/16-18 x 1-1/4	8
AB	Lockwasher, External 5/16	8

Item	Part Name	Qty.
AN	Nut, Heavy Hex Jam 5/16-18	8
AO	Washer, 11/32 x 11/16 x 1/16	8
	Bag of Loose Parts No. 62752 (Containing the Following Items)	
Z	Screw, Hex Hd. 5/16-18 x 1-1/4	4
AA	Nut, Hex 1/4-20	24
AA	Nut, Hex Heavy Jam 5/16-18	4
AB	Lockwasher, External 5/16	4
AB	Lockwasher, External 1/4	24
AN	Nut, Hex Jam 1/2-13	8
AO	Washer, 11/32 x 11/16 x 1/16	8
AP	Screw, Truss Hd. 1/4-20 x 5/8	24
AQ	Foot, Leveling 1/2	4
	Bag of Loose Parts No. 62751 (Containing the Following Items)	
X	Wrench, Hex "L" 1/8	1
X	Wrench, Hex "L" 3/32	1
X	Wrench, Hex "L" 5/32	1
Y	Nut, Self-Threading	2
Z	Screw, Hex Hd. 5/16-18 x 5/8 in. long	3
Z	Screw, Hex Hd. 5/16-18 x 3/4 in. long	2
Z	Screw, Hex Hd. 5/16-18 x 1 in. long	4
Z	Screw, Hex Hd. 5/16-18 x 1-3/4 in. long	2
Z	Screw, Hex Hd. 1/4-20 x 5/8 in. long	2
AA	Nut, Heavy Hex Jam 5/16-18	10
AA	Nut, Hex 1/4-20	2
AC	Carriage Bolt, 5/16-18 x 3/4	4
AD	Spacer, Rip Fence Guide Bar	2
AE	Tie Wire	2
AF	Screw, Pan Hd. 10-32 x 3/4	2
AG	Screw, Thumb 5/16-18 x 1	1
AB	Lockwasher, External #10	2
AB	Lockwasher, External 1/4	2
AB	Lockwasher, External 5/16	12
AO	Washer, 21/64 x 5/8 x 1/16	2

ASSEMBLY

Before mounting the saw on legs, a stand or a bench, the Table Insert and Blade Squareness must be checked at this time.

INSTALLING HANDWHEELS

1. Line up FLAT SPOTS on shaft and handwheel, push handwheel onto shaft. Install screw and lockwasher to lock handwheel on shaft.

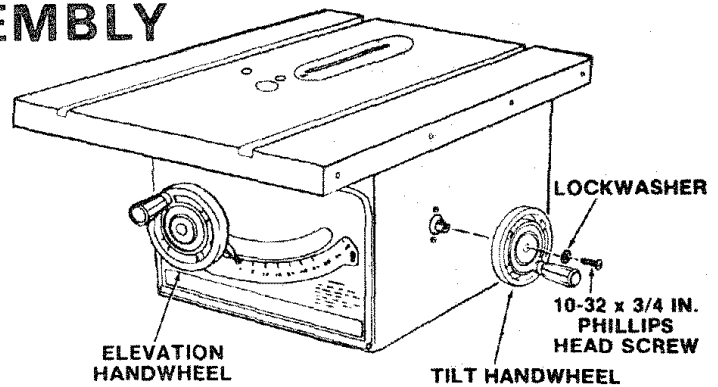

CHECKING TABLE INSERT

2. Insert should be flush with table top. Check as shown. Loosen flat head screw that holds insert and adjust the four set screws as necessary. Tighten flat head screw. Do not tighten screw to the point where it deflects the insert.

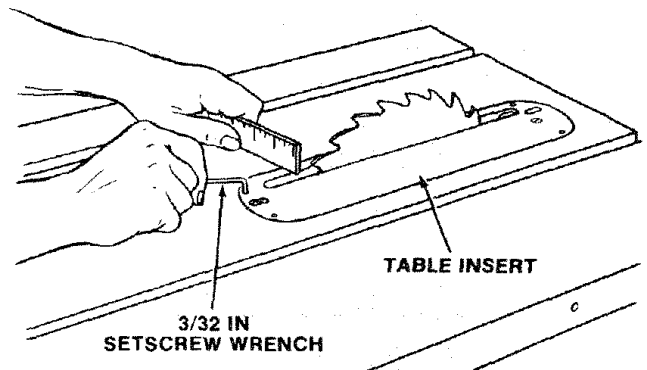

3. To remove insert.
 - A) Loosen Screw
 - B) Lift insert from front end, and pull toward front of saw.
4. To replace insert.

Place insert into insert opening in table and push toward rear of saw to engage spring clip and until keyslot in insert will drop over screw. Tighten screw.

Do not tighten screw to the point where it will deflect the insert.

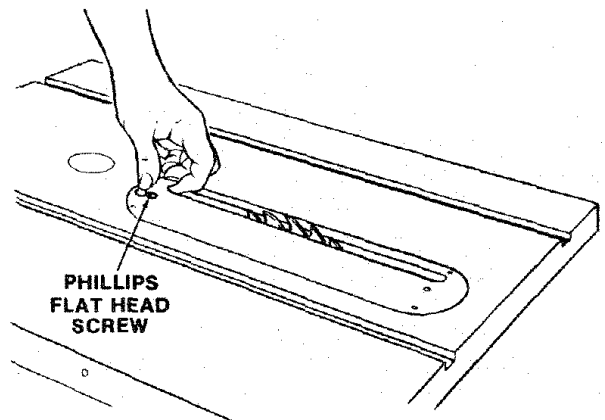

CHECKING BLADE SQUARENESS TO TABLE

IMPORTANT: BLADE must be SQUARE (90°) to TABLE, in order to proceed with assembly.

1. Turn ELEVATION handwheel clockwise until blade is up as high as it will go.
2. Check for BLADE SQUARENESS . . . if blade is not square to table, adjust it at this time.

NOTE: The combination square must be "true" -see start of "Unpacking and Checking Contents" section on page 6 for checking method.

Refer to "BLADE TILT, OR SQUARENESS OF BLADE TO TABLE" adjustment on page 34.

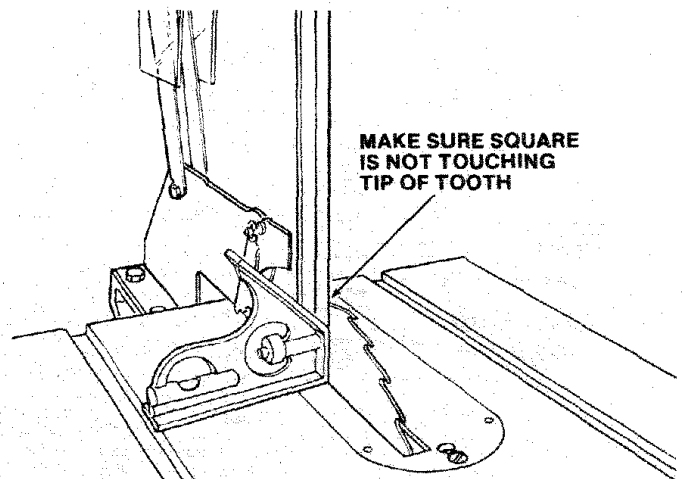

ASSEMBLING STEEL LEGS

From among the loose parts, find the following Hardware:

- 24 Truss Head Screws, 1/4-20 x 5/8 in. long (top of screw is rounded)
- 24 Lockwashers, 1/4 in. External Type (approx. dia. of hole 1/4 in.)
- 24 Hex Nuts, 1/4-20 (approx. dia. of hole 1/4 in.)
- 8 Hex Nuts, 1/2-13 (approx. dia. of hole 1/2 in.)
- 4 Leveling feet

Assemble the legs as shown . . .

1. Insert the Truss Head Screws through the holes in the legs, then through the holes in the stiffeners **MAKE SURE THE SCREWS TO THROUGH THE HOLES IN THE SIDE STIFFENERS MARKED "X"**.
2. Install the lockwashers . . . screw on the nuts but do not tighten until completely assembled.
3. Install leveling feet.

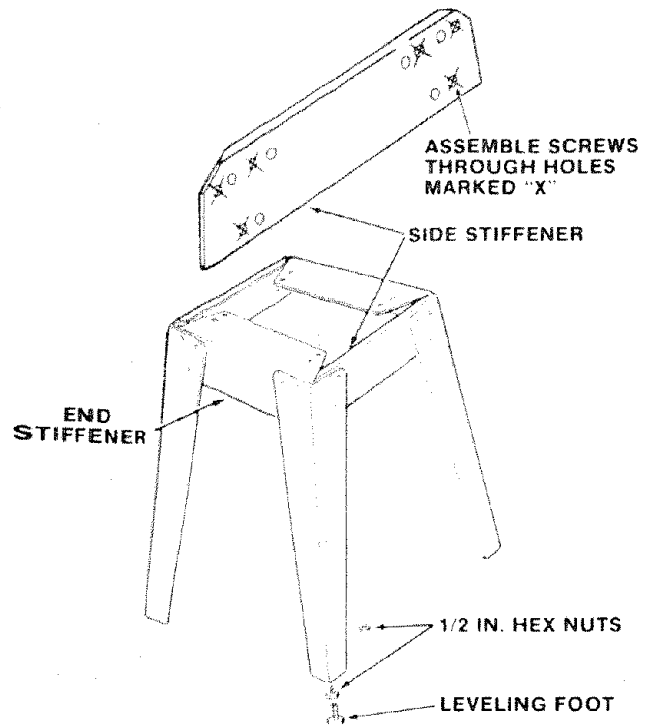

MOUNTING SAW

1. From among the loose parts, find the following hardware:
 - 4 Hex Head Screws, 5/16-18 x 1-1/4 in. long.
 - 4 Hex Nuts, 5/16-18 (approx. dia. of hole 5/16 in.)
 - 4 Lockwashers, 5/16 in. External Type (approx. dia. of hole, 5/16 in.)
 - 8 Flat Washers, (dia. of hole 11/32 in.)
2. Place saw on legs so that holes in bottom of saw line up with holes in top of legs.
3. Install screws, washers, lockwashers and nuts as shown.

If you mount the saw on any other bench, make sure that there is an opening in the top of the bench the same size as the opening in the bottom of the saw so that the sawdust can drop through. Recommended working height is 33 to 37 inches from the top of the saw table to the floor.

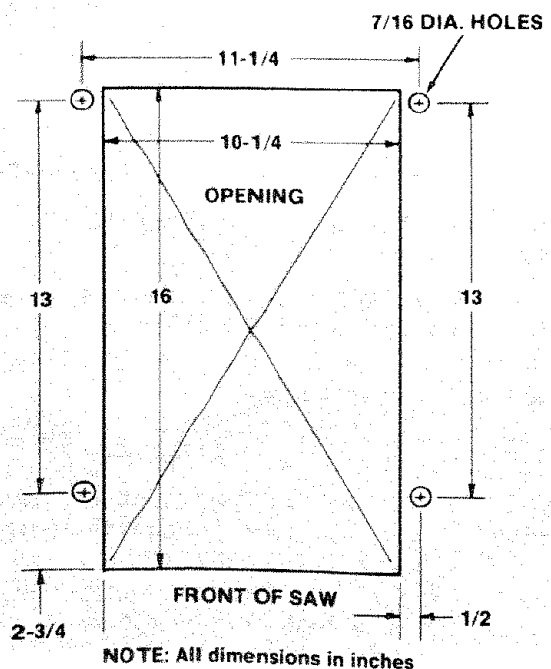
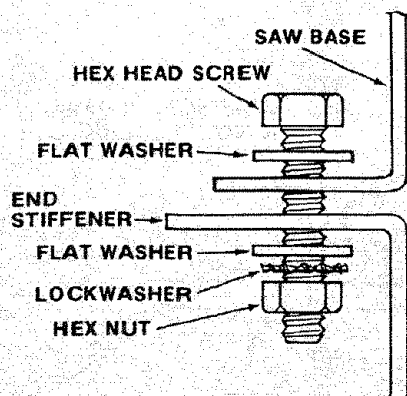
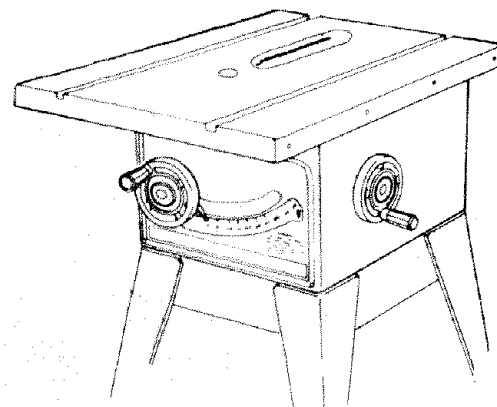

ATTACHING AND ASSEMBLING TABLE EXTENSIONS

From among the loose parts find the following hardware: (Quantity indicated is for 2 extensions)

HARDWARE FOR INSTALLING EXTENSIONS TO SAW TABLE

Ref. No.	Description	Qty.
1	Hex Hd. Screw, 5/16-18 x 1-1/4	8
2	Flat Washer (Dia. of Hole 11/32)	8
3	External Lockwasher, 5/16	8
4	Hex Nut, 5/16-18	8

1. Insert four (4) 5/16-18 x 1-1/4 in. long screws through holes in each EXTENSION.
2. Position extension against table so screws extend through holes in table.
3. Install flat washer, lockwashers, and nuts on the screws . . . DO NOT TIGHTEN.

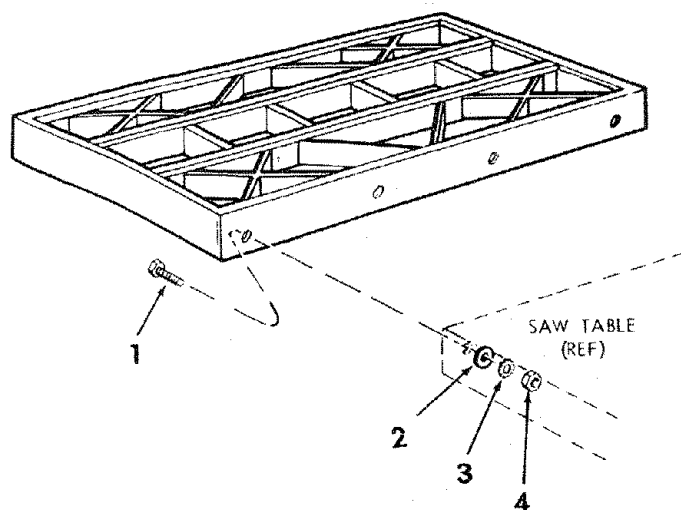

4. Line up the rear edge of extension with the rear edge of the table. Line up top surface of the extension with the top of the table at the locations indicated by the "X"s (see illustration). Use a combination square to line-up these edges. SLIGHTLY TIGHTEN nuts with a 9/16" wrench.

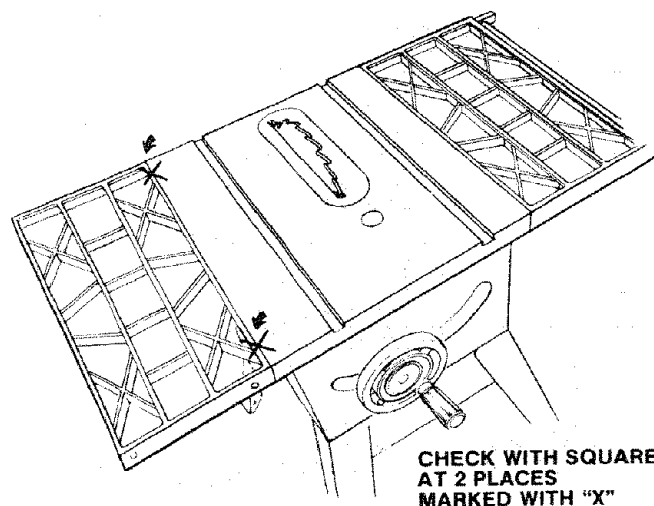

5. If adjustment is necessary, you should tap the extension into position using a hammer and a block of wood. Make sure the rear edge of extension is lined up with the rear edge of the table. Then firmly tighten nuts.
6. Repeat the same procedure to install the other extension.

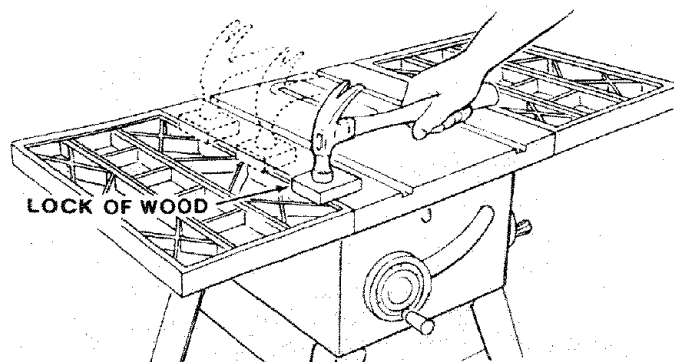

MOUNTING SWITCH

1. From among loose parts find the following:
 - 2 Hex Head Screws, 5/16-18 x 3/4 in. long
 - 2 Flatwashers (dia. of hole 21/64 in.)
 - 2 External Lockwashers
 - 2 Hex Nuts, 5/16-18
2. Insert two 3/4 inch screws through two flat washers then through holes in switch.
3. Insert screws through holes eight and ten in front fence guide bar as illustrated.
4. Install two lockwashers and nuts. Tighten nuts.

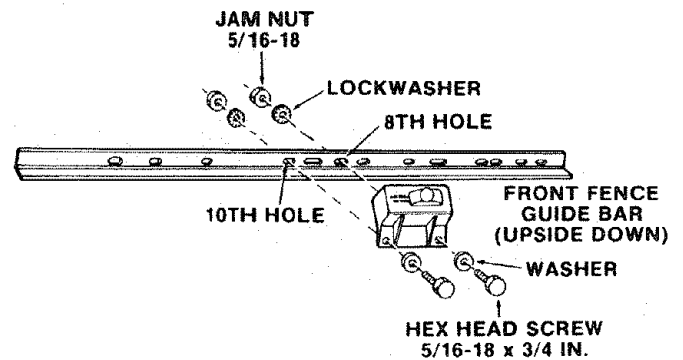

INSTALLING RIP FENCE GUIDE BARS

1. From among the loose parts find the following hardware:
 - 2 Hex Head Screws, 5/16-18 x 1-3/4 in. long
 - 2 Hex Head Screws, 5/16-18 x 1 in. long
 - 4 External Lockwashers, 5/16 in. (approx. dia. of hole 5/16 in.)
 - 4 Hex Nuts, 5/16-18 (approx. dia. of hole 5/16 in.)
 - 2 Spacers, 3/4 in. dia. x 1/2 in. long
 - 2 Self-threading nuts
 - 1 Fence Guide Bar Rod
2. Lay guide bars on saw table.

NOTE: The various holes in the bar allows them to be positioned on this saw and also makes them adaptable to other models.
3. Insert a 1-3/4 inch long screw through the **THIRD** hole IN THE FRONT BAR as illustrated ... Insert another 1-3/4 inch long screw through the **SEVENTH** hole in bar.
4. Place spacers on screws.

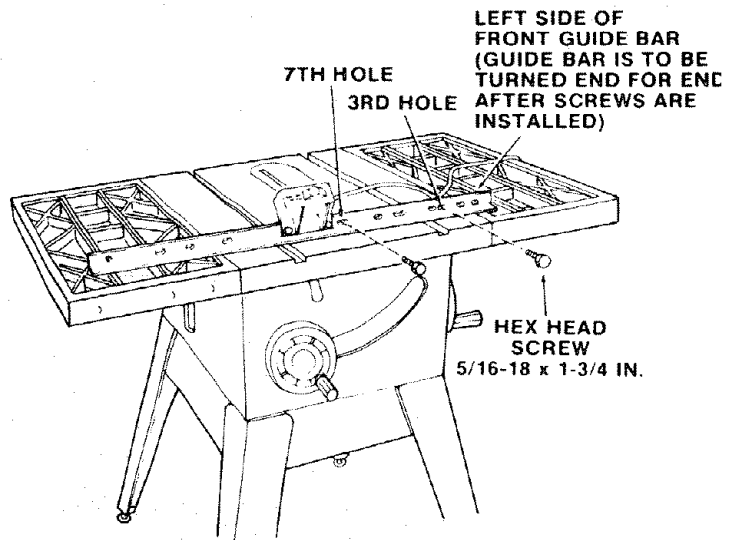

5. Turn front bar end for end and insert bolts through holes in middle and on right sides of front of saw table as illustrated ... install lockwashers and nuts. **DON'T SCREW NUTS ON ALL THE WAY**, just get them started on the screws.

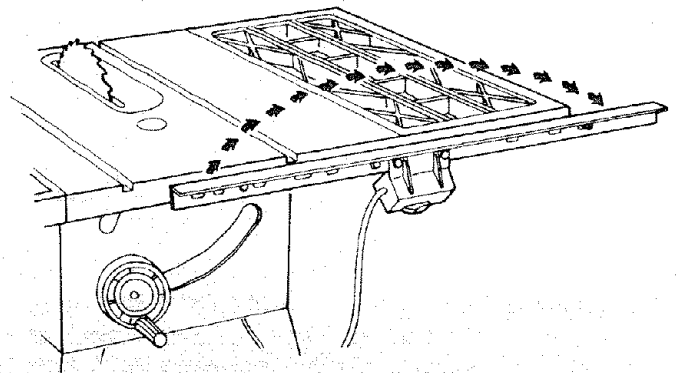

6. Insert 1 in. long screws in **SECOND** and **FOURTH** or **FIFTH** holes of rear bar and attach to table the same way as front bar.
7. Insert ends of **FENCE GUIDE BAR ROD** through holes in bars as illustrated.

NOTE: The ends of the ROD are not threaded ... the **SELF THREADING NUTS** will cut threads on the rod as they are screwed on. Just start nuts onto ends of rod.

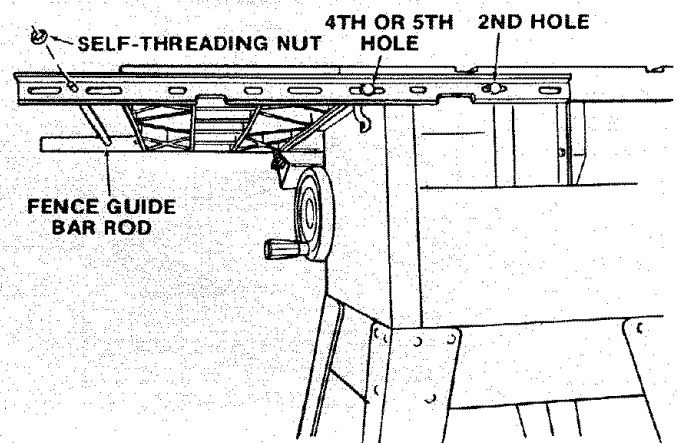

8. Hold rod with one hand and with a 1/2 in. wrench or pliers start screwing on ONE of the nuts only A TURN OR TWO . . . screw on other nut the same way.
9. Using TWO 1/2 in. wrenches or pliers tighten both of the nuts.

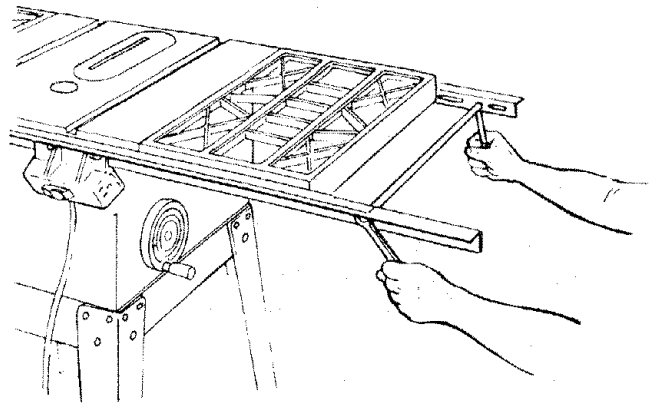

10. Slide the bars so that screws are in the MIDDLE of the slotted holes.
11. Position rip fence over miter gauge groove, holding up the rear end while engaging front end with bar lower fence onto table.

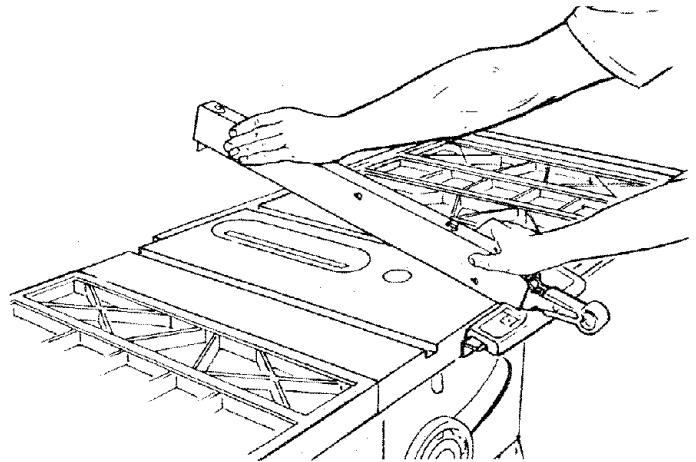

12. Raise blade all the way up.
13. Carefully move fence against blade.
14. Move front bar until "0" mark on rip scale is approximately at tip of pointer.
15. Move FRONT bar upwards until fence is approximately 1/32 in. above table . . . tighten screw at left end of bar.

NOTE: Fold a piece of newspaper making 8 thicknesses and place between rip fence and table to act as a spacer. This will hold the fence off of the table approx. 1/32 in.

16. Adjust rear bar so that the fence is approximately 1/32 in. above table make sure it is square with fence guide bar rod . . . tighten screw at end of bar.

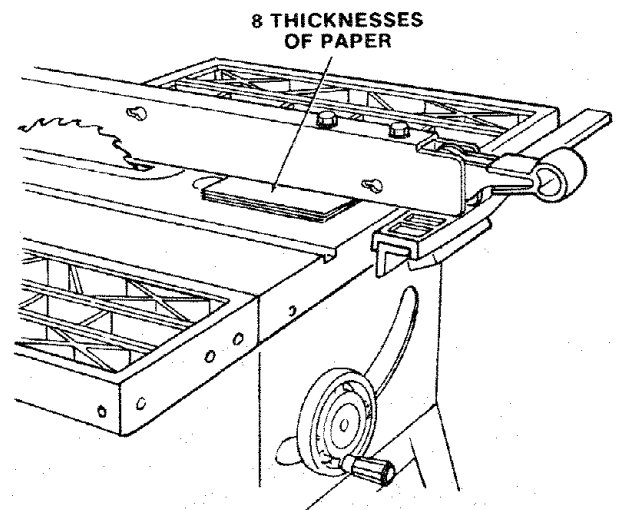

17. Move fence to RIGHT edge of table . . . make sure it is approx. 1/32 in. above table at front and rear and tighten screws.

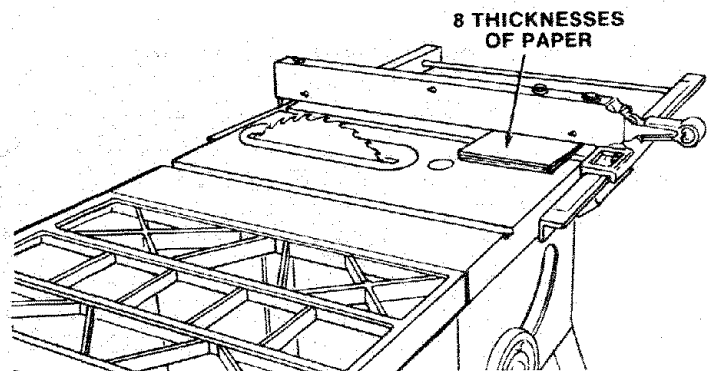

ALIGNING RIP FENCE

The fence should slide easily along the bars and always remain in alignment (parallel to sawblade and miter gauge grooves).

The alignment is maintained by a spring underneath the fence which bears against the front guide bar.

To move the fence, loosen the lock handle and grasp the fence with one hand at the front.

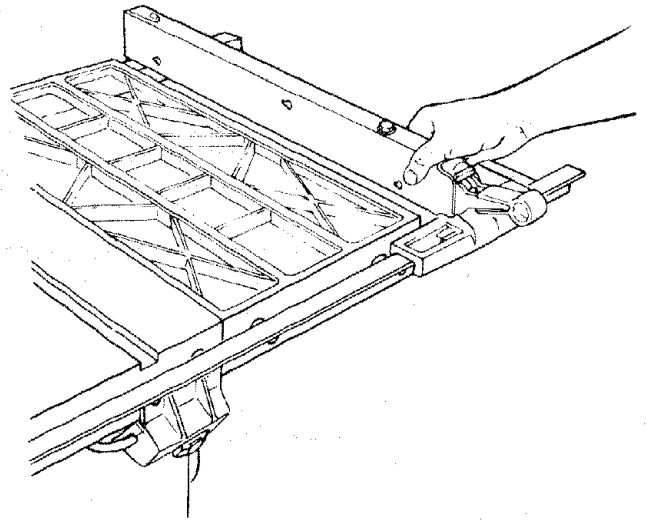

For very close adjustments, grasp the guide bar with both hands and move the fence with your thumbs.

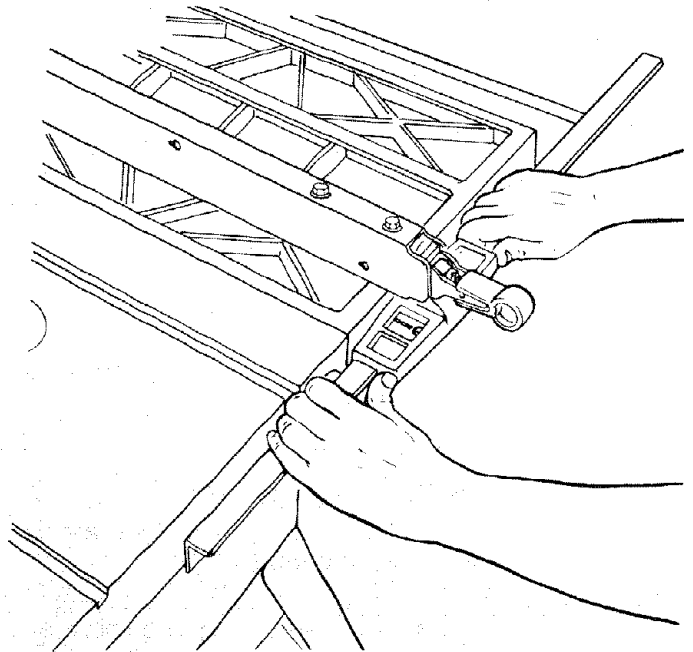

SELF ALIGNING ADJUSTMENT

Place fence on saw but **DO NOT LOCK IT**.

Move the **REAR END** of the fence slightly to the right or left . . . when you release it, the fence should "spring" back to its original position.

If it does not, the spring pressure must be **INCREASED**.

1. Loosen the screws.
2. Move Spring slightly toward front of fence.

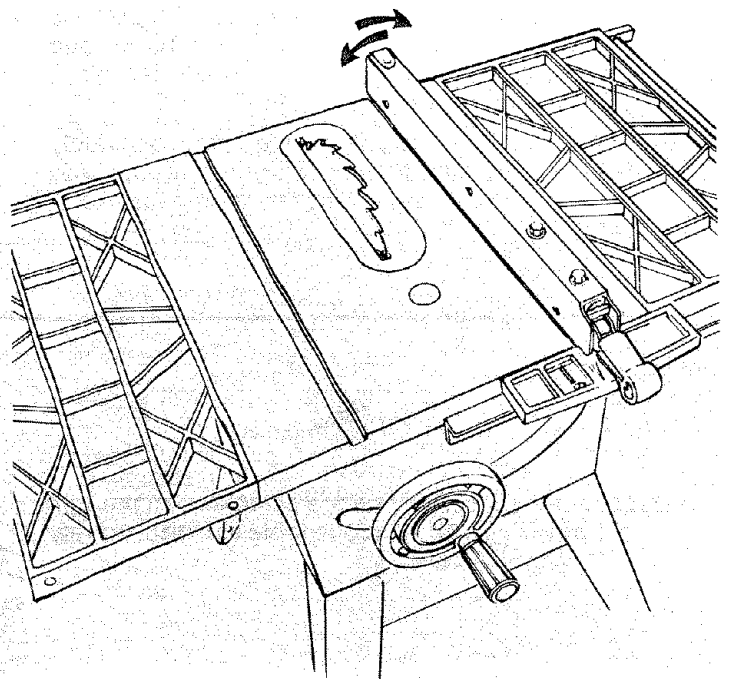

If fence does not slide easily along the bars, the pressure of the spring can be REDUCED.

1. Loosen the screws.
2. Move spring slightly toward rear of fence . . . tighten screws.

WARNING: TO AVOID INJURY FROM JAMS OR KICKBACK, BE SURE TO PROPERLY ADJUST AND PUSH LOCK LEVER ALL THE WAY DOWN UNTIL THE LEVER RESTS ON THE STOP BEFORE USING THIS RIP FENCE.

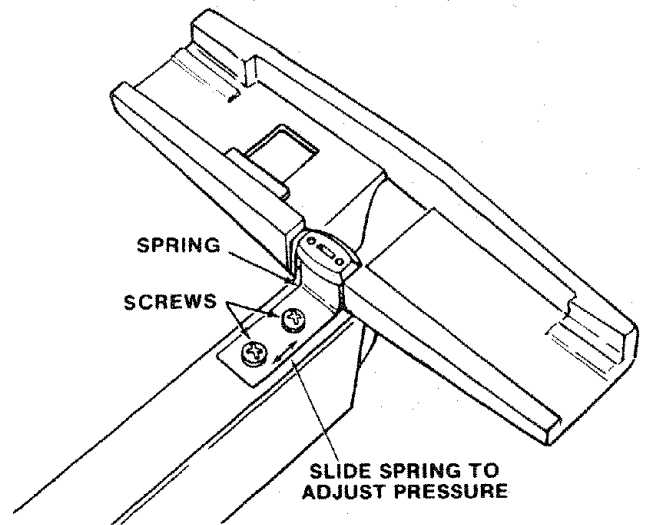

RIP FENCE LOCK LEVER ADJUSTMENT

The rip fence lock lever when locked down, should hold the rip fence securely, it should not be difficult to push down and lock.

If lock lever does not lock fence securely . . .

1. Raise lock lever.
2. Tighten the adjusting nut using a small screwdriver until the lever, when locked, holds the rip fence securely.

If lock lever is difficult to push down . . .

1. Raise lock lever.
2. Loosen the adjusting nut using a small screwdriver until the lever is easy to push down and holds the rip fence securely.

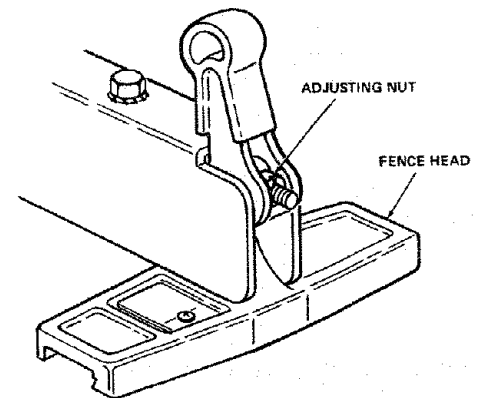

RIP FENCE ALIGNMENT ADJUSTMENT

The rip fence must be PARALLEL with the sawblade and Miter Gauge grooves . . . Move fence until it is along side of groove. Do NOT LOCK IT. It should be parallel to groove. If it is not;

1. Loosen the two "Hex Head Screws".
2. Hold fence head tightly against bar . . . move end of fence so that it is parallel with groove.
3. Alternately tighten the screws.
4. Recheck alignment.
5. Repeat steps as needed.

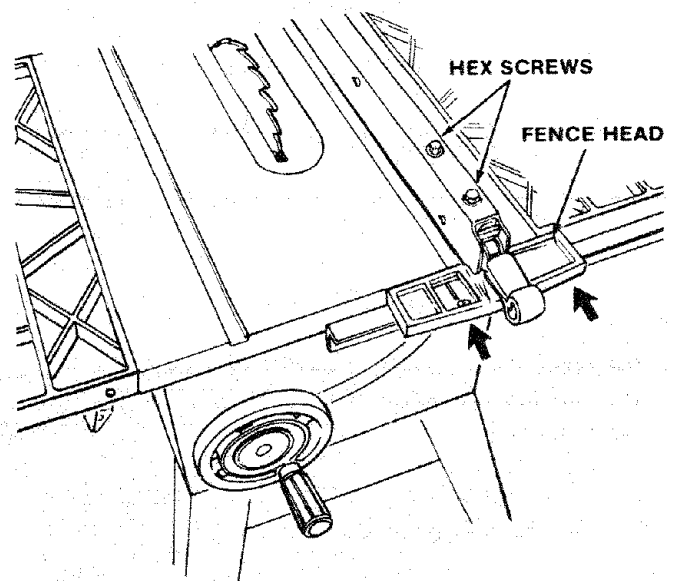

ADJUSTING RIP SCALE POINTER

1. Turn ELEVATION HANDWHEEL clockwise until blade is up as high as it will go.
IMPORTANT: BLADE must be SQUARE (90°) to TABLE, in order to ALIGN rip fence.
 2. Position fence on right side of sawblade so that it touches the sides of the teeth . . . tighten lock handle.
 3. Loosen screw holding the pointer . . . adjust pointer so that it points to "0" . . . tighten screw.
- NOTE:** If you cannot adjust pointer so that it points to "0", loosen the screws holding the front guide bar and move the guide bar.

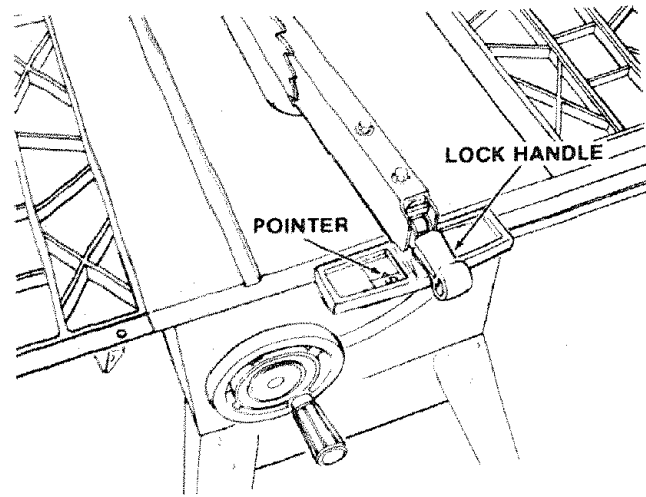

INSTALLING BLADE GUARD

1. From among the loose parts, find:
 - 2 Hex Head Screws, 1/4-20 x 5/8 in. long
 - 3 Hex Head Screws, 5/16-18 x 5/8 in. long
 - 2 Hex Head Screws, 5/16-18 x 1 in. long
 - 2 Hex Nuts, 1/4-20 (approx. dia. of hole 1/4 in.)
 - 2 Lockwashers, 1/4 in. External Type (approx. dia. of hole 1/4 in.)
 - 2 Lockwashers, 5/16 in. External Type (approx. dia. of hole 5/16 in.)
 - 1 Thumbscrew
 - Blade Guard Support
 - Spreader Support
 - Spreader Rod
2. Before installing the blade guard, you must check the heeling adjustment (parallelism of sawblade to miter gauge groove). The procedure for making this check and adjusting it are found in the "Adjustments" section of this manual. Refer to "Heeling Adjustment or Parallelism of Saw Blade to Miter Gauge Groove".
3. Lower the blade.
4. Screw the MOTOR BASE CLAMP SCREWS part way into cradle. Screw the 5/16-18 x 5/8 inch Hex Head screw into the blade guard support.
5. Attach BLADE GUARD SUPPORT. . . DO NOT TIGHTEN SCREWS.

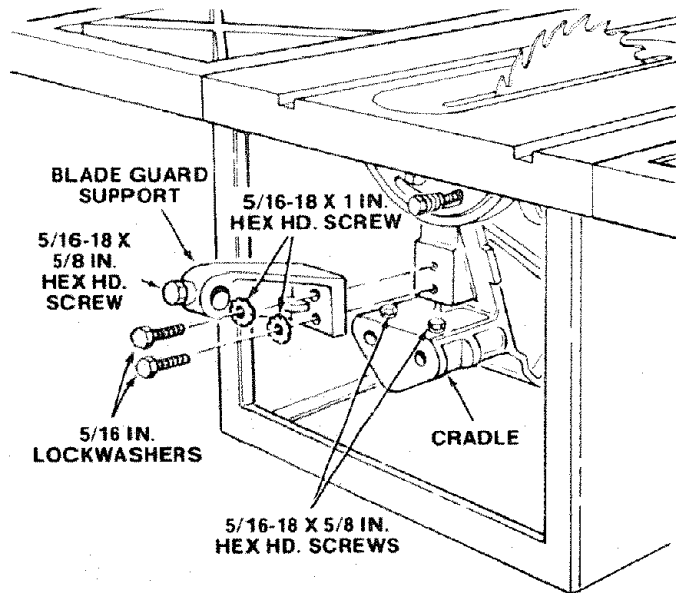

6. Insert SPREADER ROD into SPREADER SUPPORT until pin fits into notch. Insert THUMBSCREW and tighten it.

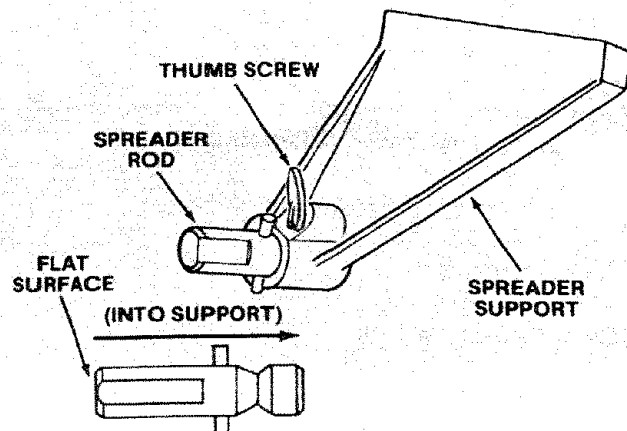

7. Slide SPREADER ROD into BLADE GUARD SUPPORT until end of ROD is even with edge of SUPPORT . . . Tighten Hex Head Screw in support.
8. Attach SPREADER to SPREADER SUPPORT so that the edge of the spreader is even with the edge of the spreader support . . . tighten screws.
9. Raise ANTIKICKBACK PAWL (hold it in place with a piece of masking tape)
 . . . align spreader SQUARE to table
 . . . Tighten both 5/16-18 x 1 in. HEX HEAD SCREWS.

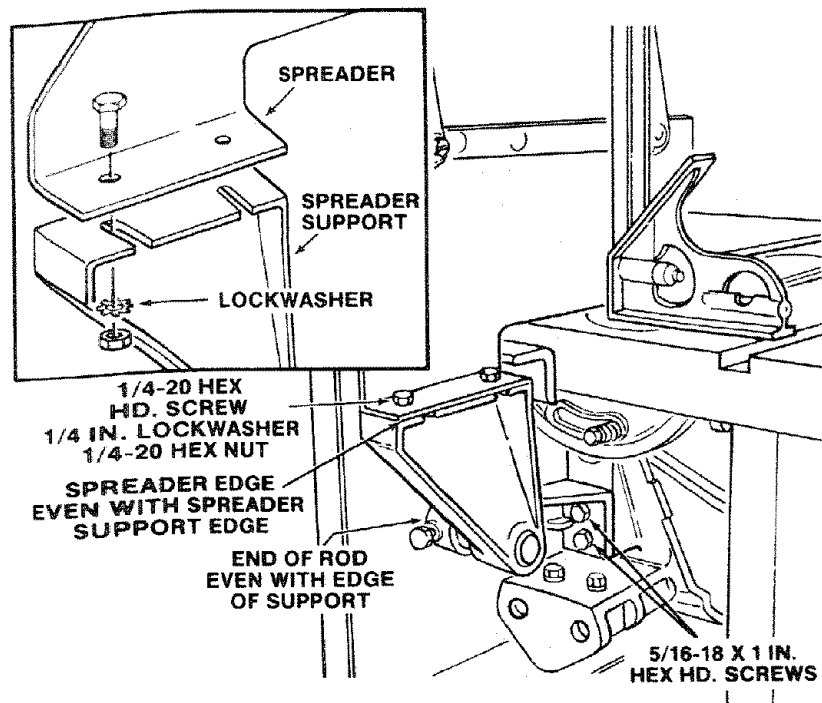

10. Raise blade all the way up . . . make sure it is square with table.
11. Raise Blade Guard . . . lift up both ANTIKICKBACK PAWLS . . . insert one of the SETSCREW WRENCHES in the notches to hold the pawls out of the way.
12. Lay blade of square or other straightedge alongside of blade.
13. Loosen Hex Head Screw in BLADE GUARD SUPPORT and move spreader so that it touches blade of square . . . tighten screw.
14. **NOTE:** The spreader is now square with the table and approximately in line with the sawblade. The spreader requires further adjustment to align it PARALLEL to the blade and in the MIDDLE of the cut (KERF) made by the sawblade.

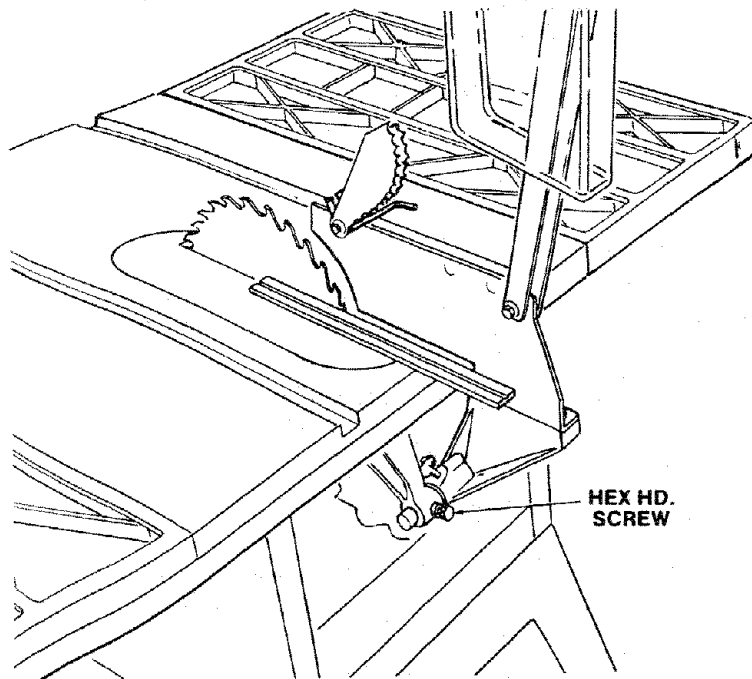

15. **IMPORTANT:** To work properly, the SPREADER must always be PARALLEL to the sawblade and adjusted so the cut workpiece will pass on either side at the spreader without binding or skewing to the side.

NOTE: The spreader is thinner than the width of the cut (KERF) made by the sawblade by approximately six thicknesses of paper.

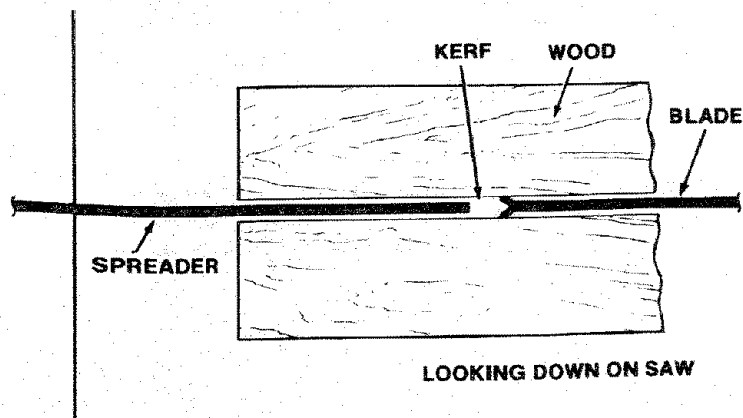

16. Make two folds in a small piece (6 x 6 in.) of ordinary NEWSPAPER making three thicknesses. The folded paper will be used as a "spacing gauge".

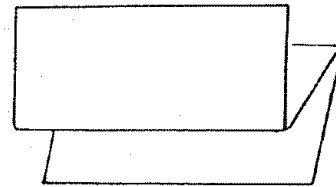

17. Place RIP FENCE on table . . . CAREFULLY move it against blade so that it is parallel to the blade, and just TOUCHES tips of saw teeth . . . tighten RIP FENCE LOCK LEVER.
18. Insert folded paper between SPREADER and FENCE.
19. Using a 7/16" wrench, loosen the 1/4-20 hex head screws so the spreader can slide sideways.
20. Hold spreader flat against fence . . . tighten screws using 7/16" wrench.
21. To remove BLADE GUARD and SPREADER, loosen THUMBSCREW . . . DO NOT LOOSEN OTHER SCREWS. This lets you remove and replace the guard without disturbing the spreader alignment.

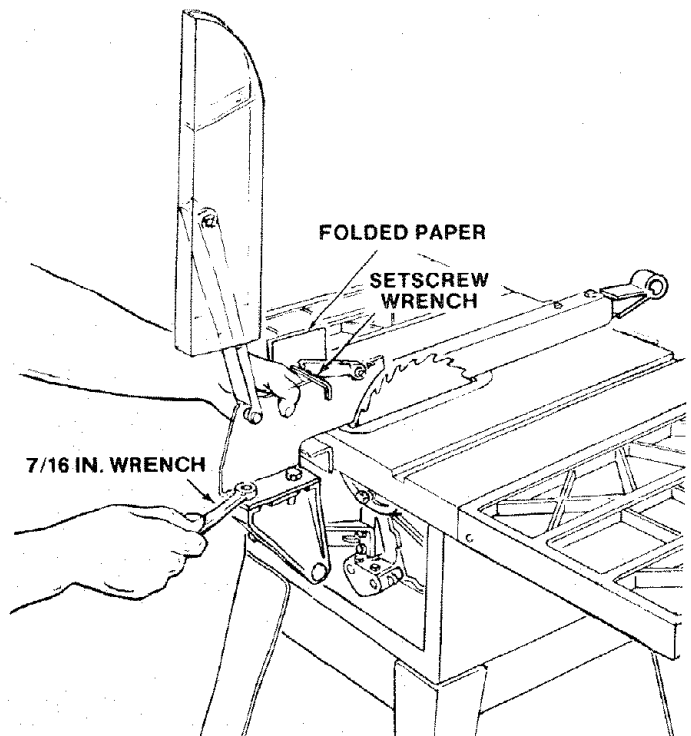

MOUNTING THE MOTOR

CHECK MOTOR ROTATION

1. The motor must rotate CLOCKWISE when reviewed from the 5/8 in. shaft.
2. MAKE SURE "KEY" IS REMOVED FROM SHAFT.
3. Place the motor on your workbench or on the floor.
4. Plug the cord into a properly grounded outlet (See "Motor Specifications and Electrical Requirements" Section). Notice the rotation of the shaft. If it is not turning CLOCKWISE, REMOVE the plug from the outlet, and change the rotation of the motor according to the instructions furnished with the motor.

WARNING: FOR YOUR OWN SAFETY, MAKE SURE PLUG IS NOT CONNECTED TO POWER SOURCE OUTLET WHEN CHANGING MOTOR ROTATION.

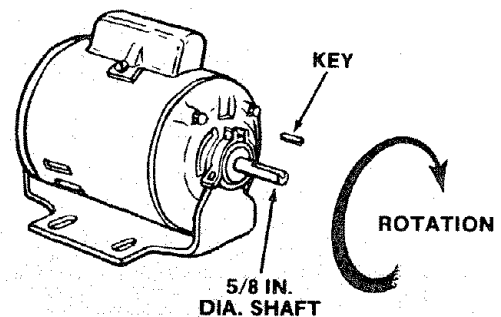

5. From among the loose parts, find the following hardware:
 - 4 Carriage Bolts, 5/16 - 18 x 3/4 in. long
 - 4 Hex Nuts, 5/16-18
(approx. dia. of hole 5/16 in.)
 - 4 Lockwashers, 5/16 in. External Type
(approx. dia. of hole 5/16 in.)
6. Remove Blade Guard and Spreader.
7. Place motor on MOTOR BASE . . . insert bolts through holes in base . . . then through the motor. Install lockwashers, and nuts.
8. Position motor so that edge of MOTOR FOOT and MOTOR BASE are even . . . slide motor all the way to the RIGHT . . . tighten the four nuts.
9. Loosen set screw in motor pulley using 5/32 in. setscrew wrench. Slide pulley on shaft with HUB away from motor. DO NOT TIGHTEN SET-SCREW.
10. Install 3/16 in. square key (furnished with motor) in grooves in pulley and motor shaft. DO NOT TIGHTEN SETSCREW.

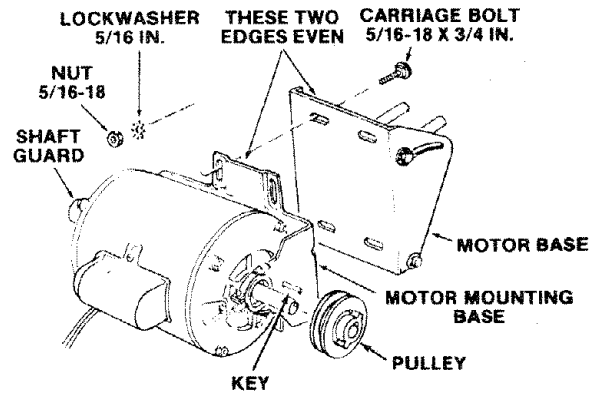

11. Lift motor and insert the TWO PINS on motor base into HOLES in cradle . . . push motor in as far as it will go.
12. Lower the blade . . . install belt on saw pulley and motor pulley.
13. Sight along edges of both pulleys and move motor pulley so that belt is parallel to the edges of both pulleys . . . tighten the setscrew in the motor pulley.
14. **IMPORTANT:** Measure the distance from end of motor shaft to pulley . . . mark this dimension down; you will need it later when reinstalling the pulley.
15. Make sure blade is 90° to table . . . raise it all the way up.
16. Lift motor until edge of washer is even with end of slot . . . tighten pivot screw. In this position, pull motor toward you (pins will slide out of cradle) until belt is TIGHT . . . tighten the two MOTOR BASE CLAMP SCREWS.
17. Loosen Pivot Screw slightly.
18. Lower the saw blade all the way down.
19. **IMPORTANT:** Motor should pivot freely downward as blade is lowered. If it does not, LOOSEN the PIVOT SCREW some more.
20. Pivot screw must be adjusted only tight enough to allow motor to pivot FREELY as blade is raised or lowered. This will maintain constant tension on belt.

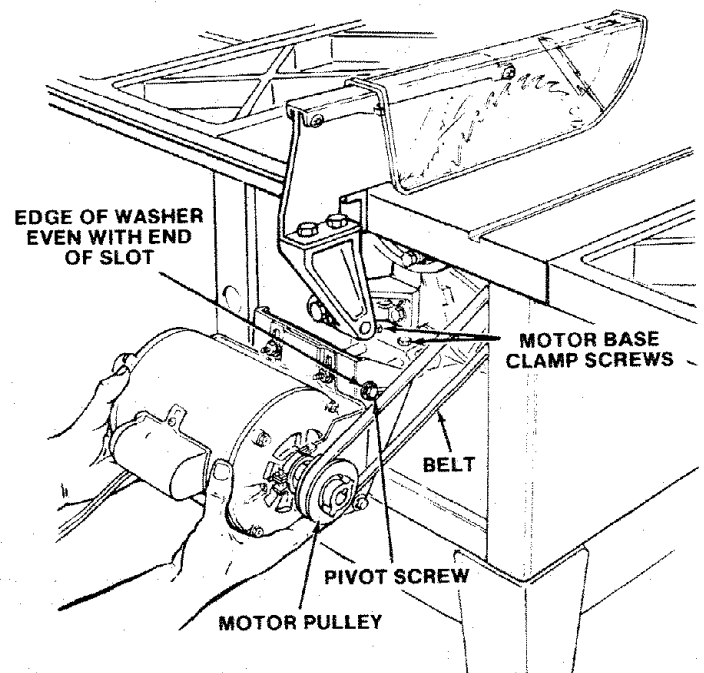

- Loosen the two **MOTOR CLAMP SCREWS** on each end of motor. Rotate the motor so that the **CAPACITOR COVER** is on top . . . tighten the screws. The ventilation holes are now facing downward which will help prevent sawdust from entering motor.

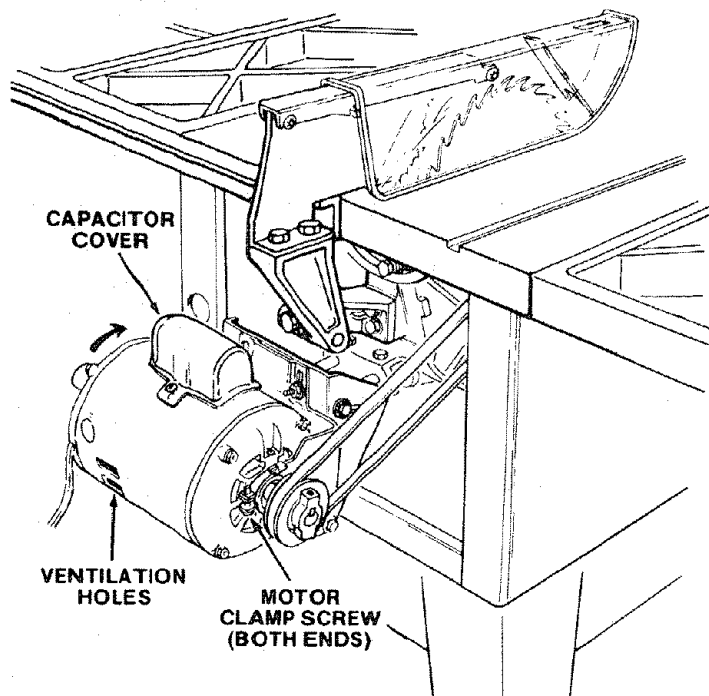

INSTALLING BELT GUARD

- Remove the belt and motor pulley.
- Screws furnished with guard are "self threading" . . . screw them into holes in **BELT GUARD SUPPORT BRACKET**, then remove them.
- Position **BELT GUARD SUPPORT BRACKET** and **BELT GUARD SUPPORT** as shown and install the screws . . . make sure motor shaft is in **CENTER** of hole in **SUPPORT**.

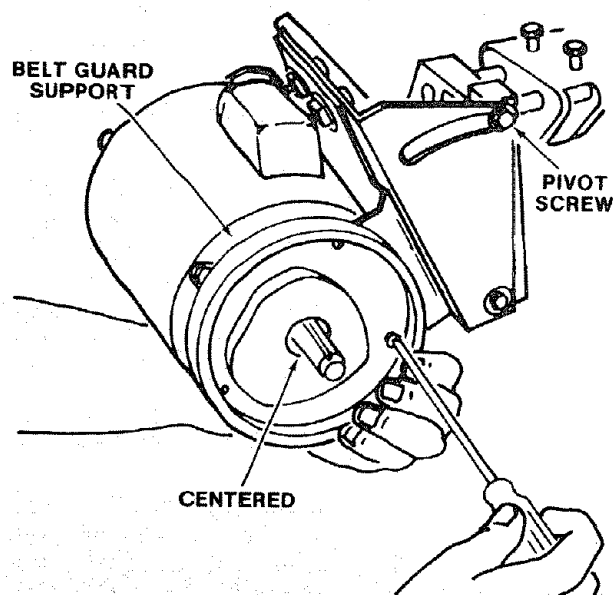
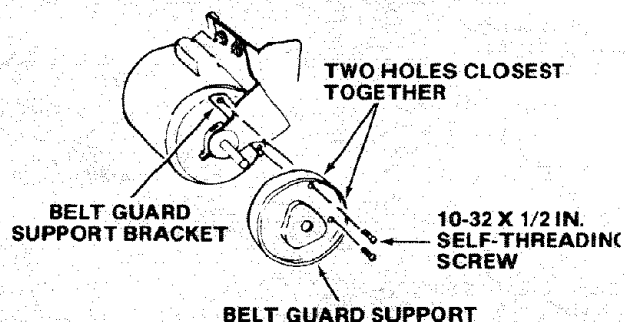

- Install three **CLIPS** (furnished with guard) 90° apart starting with one clip at the end of the guard as shown . . . **LONG END** of clip facing **AWAY** from you.

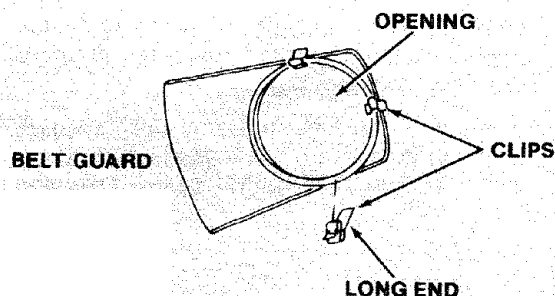

5. Reinstall motor pulley the same way it was when you aligned the belt.
6. Place belt on SAW PULLEY . . . insert end of belt through opening in END of guard.
7. Slip belt over motor pulley.

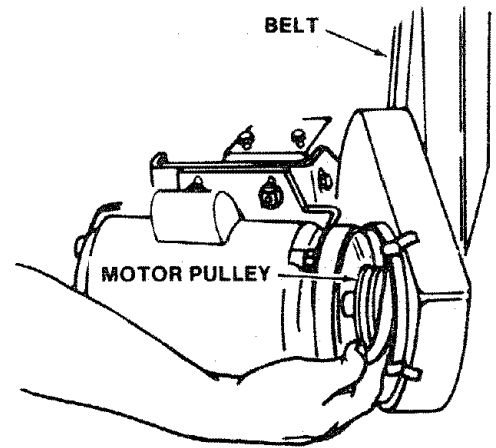

8. Press guard onto support so that bottom of guard is approximately 3/4 in. away from belt.

NOTE: To remove guard, lift up on LONG TABS of clips . . . pull guard outward. The clips should remain on the BELT GUARD SUPPORT.

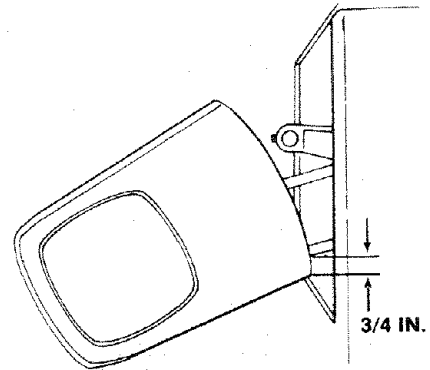

PLUGGING IN MOTOR

1. From among the loose parts, find two wire ties.
2. Route motor cord along right side of cabinet and snap ties in 1/4" hole in side of cabinet. Secure two cords in wire ties.
3. Plug motor cord into outlet on side of switch box.

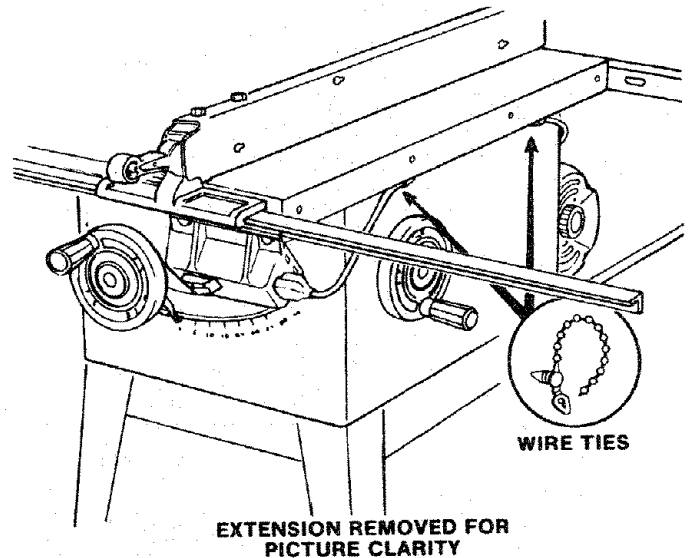

GETTING TO KNOW YOUR SAW

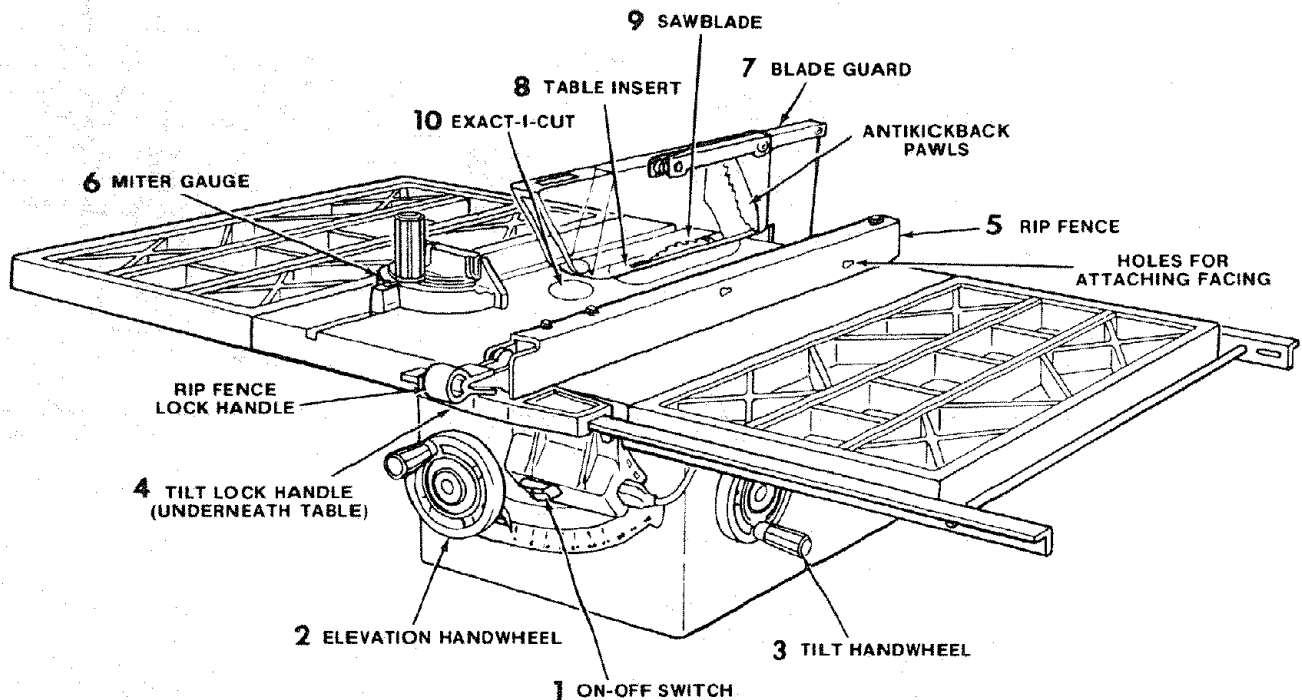

1 ON-OFF SWITCH

CAUTION: Before turning switch on, make sure the blade guard is correctly installed and operating properly.

The On-Off Switch has a locking feature. THIS FEATURE IS INTENDED TO HELP PREVENT UNAUTHORIZED AND POSSIBLE HAZARDOUS USE BY CHILDREN AND OTHERS.

- A. TO turn saw ON . . . stand to either side of the blade never in line with it . . . insert finger under switch lever and pull END of lever out. After turning switch ON, always allow the blade to come up to full speed before cutting. Do not cycle the motor switch on and off rapidly, as this may cause the sawblade to loosen. In the event this should ever occur, allow the sawblade to come to a complete stop and retighten the arbor nut normally, not excessively. Never leave the saw while the power is "ON".
- B. TO turn saw OFF . . . PUSH lever in. Never leave the saw until the cutting tool has come to a complete stop.
- C. TO lock switch in OFF position . . . hold switch IN with one hand . . . REMOVE key with other hand.

WARNING: FOR YOUR OWN SAFETY, LOWER BLADE OR OTHER CUTTING TOOL BELOW TABLE SURFACE. (IF BLADE IS TILTED, RETURN IT TO VERTICAL (90°) POSITION). ALWAYS LOCK THE SWITCH "OFF". WHEN SAW IS NOT IN USE . . . REMOVE KEY AND KEEP IT IN A SAFE PLACE . . . ALSO . . . IN THE EVENT OF A POWER FAILURE (ALL OF YOUR LIGHTS GO OUT) TURN SWITCH

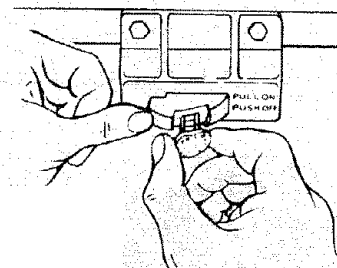
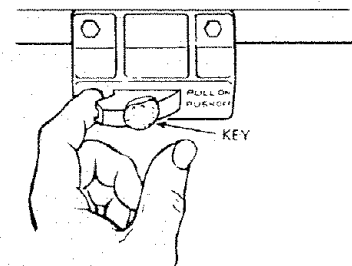
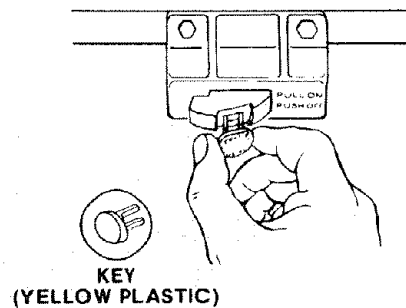

OFF . . . LOCK IT AND REMOVE THE KEY. THIS WILL PREVENT THE SAW FROM STARTING UP AGAIN WHEN THE POWER COMES BACK ON.

2 ELEVATION HANDWHEEL . . . elevates or lowers the blade. Turn clockwise to elevate . . . counterclockwise to lower.

3 TILT HANDWHEEL . . . tilts the blade for bevel cutting. Turn clockwise to tilt toward left . . . counterclockwise to tilt toward right.

When the blade is tilted to the LEFT as far as it will go, it should be at 45° to the table and the bevel pointer should point 45°.

NOTE: There are LIMIT STOPS inside the saw which prevent the blade from tilting beyond 45° to the LEFT and 90° to the RIGHT. (See "Adjustments" section "Blade Tilt, or Squareness of Blade to Table").

4 TILT LOCK HANDLE . . . locks the blade in the desired tilt position. To loosen, turn counterclockwise. Push handle in and turn it to another position if necessary in order to tighten or loosen.

5 RIP FENCE . . . is locked in place by pushing the lock lever down until the lever rests on the stop. To move the fence, lift the lock lever and grasp the fence with one hand at the front.

Holes are provided in the rip fence for attaching a wood facing when using the dado head, or molding head.

Select a piece of smooth straight wood approx. 3/4 in. thick and the same size as the rip fence.

Attach it to the fence with three Round Head #10 Wood Screws 2 in. long. To remove the facing, loosen the screws, slide the facing forward and pull the screws through the round holes.

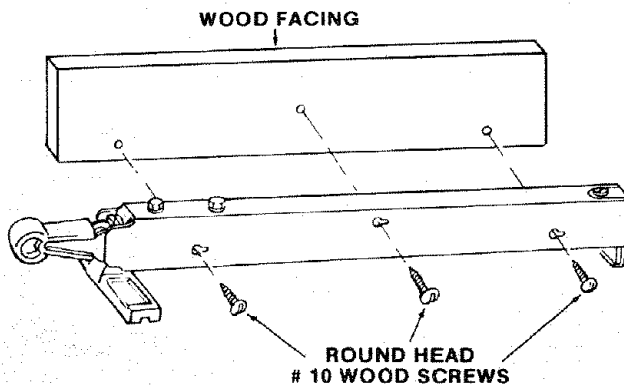

6 MITER GAUGE . . . head is locked in position for crosscutting or mitering by tightening the lock knob. ALWAYS LOCK IT SECURELY WHEN IN USE.

There are two slots for the stop pin at the 45 degree right and left positions for conveniently setting the Miter Gauge to cut miters.

NOTE: The slots for the stop pin and the graduations are manufactured to very close tolerances which provide accuracy for average woodworking. In some cases where extreme accuracy is required, when making angle cuts, for example, make a trial cut and then recheck it.

If necessary, the miter gauge head can then be swiveled slightly to compensate and then locked.

Slots are provided in the miter gauge for attaching an AUXILIARY FACING to make it easier to cut long pieces. Be positive facing does not interfere with the proper operation of the saw blade guard.

Select a suitable piece of smooth straight wood . . . drill two holes through it and attach it with screws.

NOTE: When bevel crosscutting, attach facing so that it extends to the right of the miter gauge and use the miter gauge in the groove to the right of the blade.

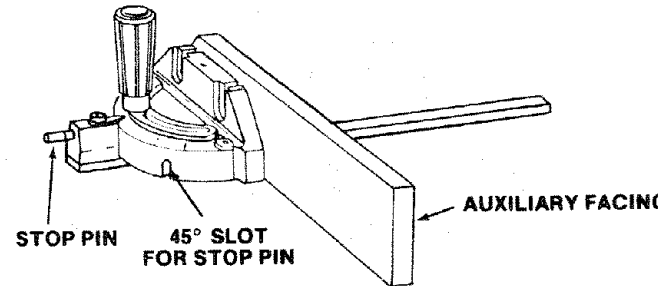

7 BLADEGUARD must always be in place and working properly for all thru-sawing cuts. That is, all cuts whereby the blade cuts completely through the workpiece.

To remove the guard for special operations, loosen the thumbscrew and slide the guard off of the rod. DO NOT DISTURB THE SETTING OF THE ROD.

When replacing the guard, make sure the PIN in the rod engages with the NOTCH in the spreader support. Make sure thumbscrew is tightened securely.

8 TABLE INSERT is removable for removing or installing blades or other cutting tools.

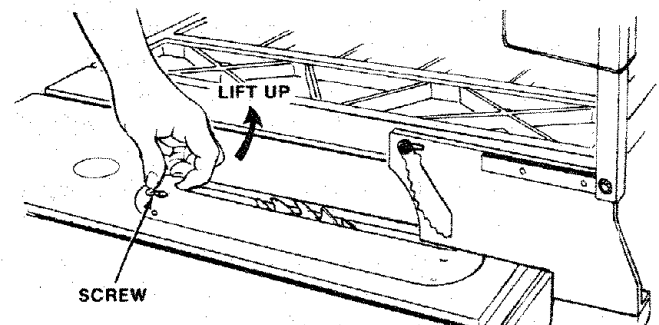

WARNING: FOR YOUR OWN SAFETY, TURN SWITCH "OFF" AND REMOVE PLUG FROM POWER SOURCE OUTLET BEFORE REMOVING INSERT.

- Lower the blade below the table surface.
- Raise blade guard.
- Loosen Screw.
- Lift insert from the front end, and pull toward front of saw.

NEVER OPERATE THE SAW WITHOUT THE PROPER INSERT IN PLACE. USE OF THE SAW BLADE INSERT WHEN SAWING . . . USE THE COMBINATION DADO MOLDING INSERT WHEN DADOING OR MOLDING.

9 REMOVING AND INSTALLING SAWBLADE.

WARNING: FOR YOUR OWN SAFETY, TURN SWITCH "OFF" AND REMOVE PLUG FROM POWER SOURCE OUTLET BEFORE REMOVING OR INSTALLING SAWBLADE.

- A. Raise Blade Guard . . . remove insert.
- B. To REMOVE blade, place a block of wood against front of blade . . . PULL arbor wrench toward you to LOOSEN arbor nut.
- C. To TIGHTEN arbor nut, place a block of wood against rear of blade . . . PUSH wrench away from you.

When installing the blade . . . make sure the teeth are pointing toward the front of the saw . . . and that the blade and collars are clean, and free from any burrs.

The HOLLOW side of the collar must be against the blade.

Always tighten the arbor nut securely.

NOTE: When using the Dado or Molding Head, it is not necessary to install the loose collar.

To replace insert.

Place insert into insert opening in table and push toward rear of saw to engage spring clip and until keyslot in insert will drop over screw. Tighten screw.

Do not tighten screw to the point where it will deflect the insert.

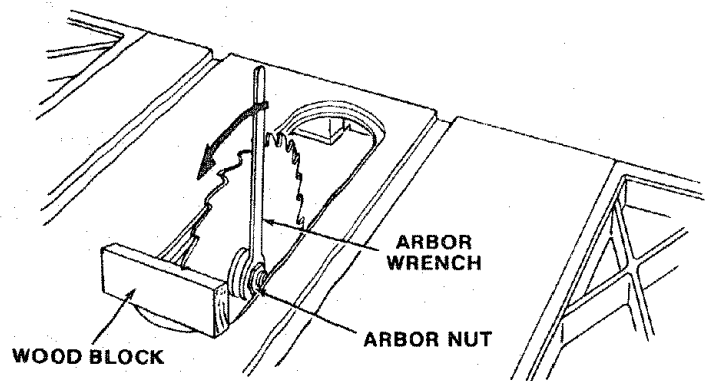

BLADE GUARD NOT SHOWN FOR PICTURE CLARITY

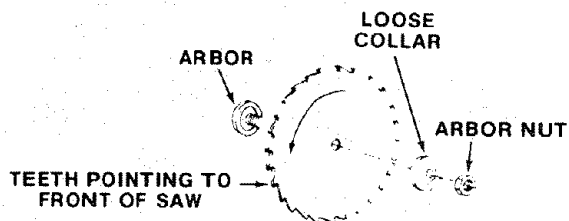
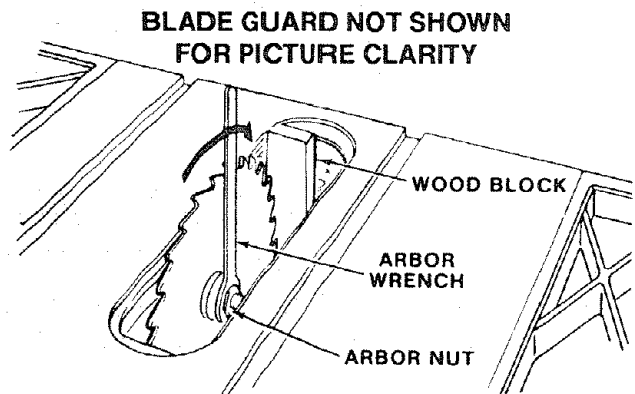

10 EXACT-I-CUT

The "yellow" plastic disc imbedded in the table in front of the sawblade, is provided for marking the location of the "sawcut" on the workpiece.

- A. Check disc . . . if it is above table surface, place a piece of hardwood on top of it and tap it down.
- B. With blade 90° (square to table) cut off a piece of wood.
- C. Pull miter gauge back until wood is over disc. Using very sharp pencil, mark a line on disc.
- D. With miter gauge in right hand groove, follow same procedure and mark another line on disc.
- E. These lines indicate the "path" of the cut (kerf) made by the sawblade.
- F. When cutting the workpiece, line up mark on workpiece with line on disc.

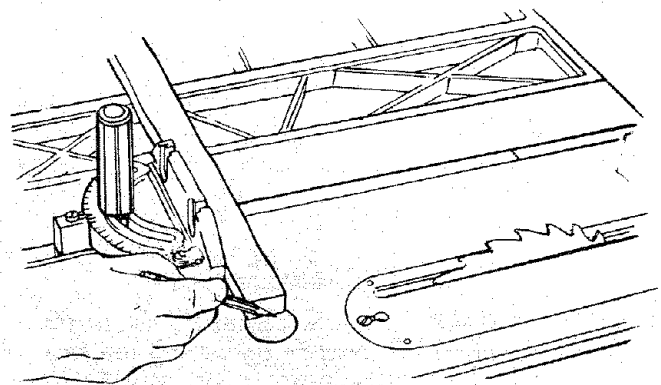

BLADE GUARD NOT SHOWN FOR PICTURE CLARITY

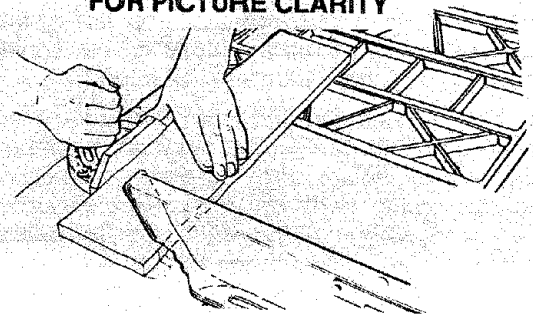

BASIC SAW OPERATION

WORK HELPERS

Before cutting any wood on your saw, study all of the "Basic Saw Operations".

Notice that in order to make some of the cuts, it is necessary to use certain devices "Work Helpers" like the Push Stick, the Push Block and the Auxiliary Fence/Work Support, which you can make yourself.

After you have made a few practice cuts, make up these "helpers" before starting any projects. Make the "Push Stick" first.

PUSH STICK AND PUSH BLOCK

Make the Push Stick using a piece of 1 x 2, or rip one from a wide board, say 11-1/2 in. wide, and set the rip fence 9-7/8 in. from the sawblade.

Make the Push Block using a piece of 3/8 in. and 3/4 in. plywood.

The small piece of wood 3/8 in. x 3/8 in. x 2-1/2 in. should be GLUED to the plywood . . . DO NOT USE NAILS. This is to prevent dulling the sawblade in the event you mistakenly cut into the push block.

Position the handle in the center of the plywood and fasten together with glue and woodscrews.

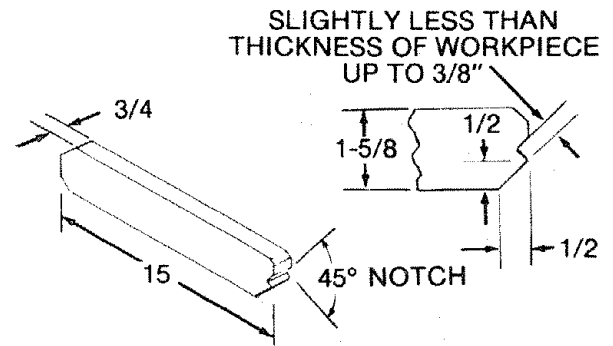

NOTE: All dimensions in inches

PUSH STICK

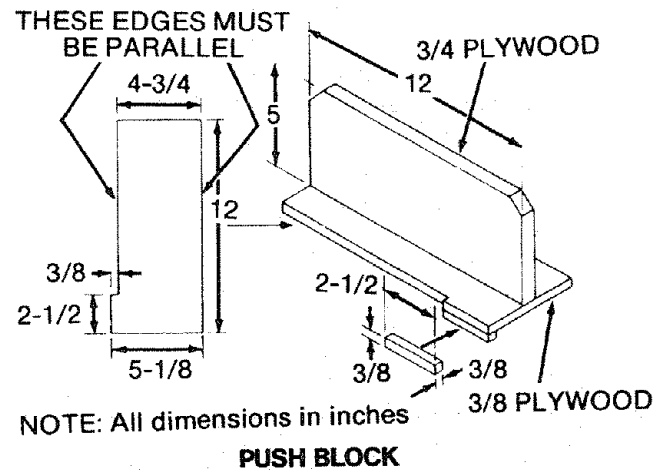

NOTE: All dimensions in inches

PUSH BLOCK

AUXILIARY FENCE/WORK SUPPORT

Make one using a piece of 3/8 in. and 3/4 in. plywood. Fasten together with glue and wood screws.

NOTE: Since the Push Block is used with the Auxiliary Fence, the 4-3/4 in. dimensions must be held identical on both the pieces.

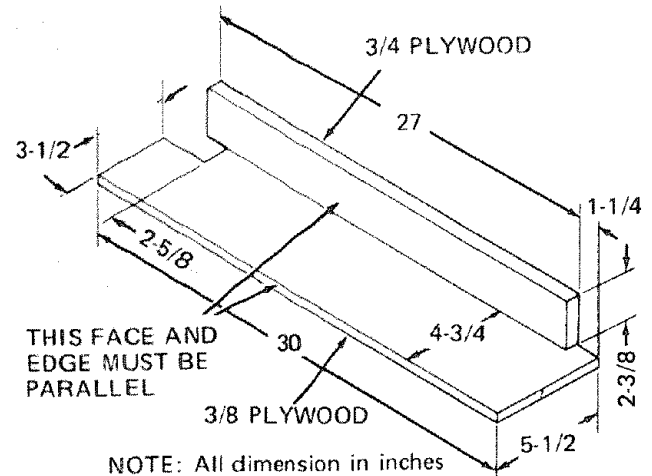

NOTE: All dimension in inches

AUXILIARY FENCE/WORK SUPPORT

AUXILIARY PANEL WORK SUPPORT

Make using a piece of 3/4" and 3/8" plywood. Fasten together with glue and wood screws. Use this auxiliary panel work support only when cutting large panels that require the rip fence to be positioned past the exposed side of the extension.

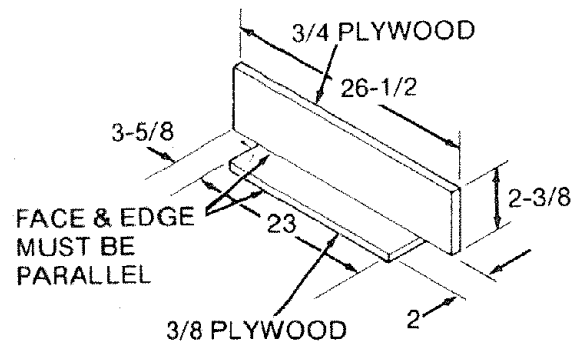

NOTE: All dimension in inches

AUXILIARY PANEL/WORK SUPPORT

SAFETY INSTRUCTIONS FOR BASIC SAW OPERATIONS

BEFORE EACH USE:

1. Inspect your saw.
 - a. To avoid injury from accidental starting, unplug the saw, turn the switch off and remove the switch key before raising or removing the guard, changing the cutting tool, changing the setup or adjusting anything.
 - b. Check for alignment of moving parts, binding of moving parts, breakage of parts, mounting, and any other conditions that may affect the way it works. If any part is missing, bent, or broken in any way, or any electrical parts don't work properly, turn the saw off and unplug the saw.
 - c. Replace damaged, missing, or failed parts before using the saw again.
 - d. Use the sawblade guard, spreader, and anti-kickback pawls for any thru-sawing (whenever the blade comes through the top of the work-piece). Make sure the pawls work properly.
- e. **REMOVE ADJUSTING KEYS AND WRENCHES.** Form habit of checking for and removing keys and adjusting wrenches from tool before turning it on.
- f. To avoid injury from jams, slips or thrown pieces (kickback and throwback):
 1. **USE ONLY RECOMMENDED ACCESSORIES** (See page 42) - Follow the instructions that come with the accessories. Using other accessories may be dangerous.
 2. Choose the right blade or cutting accessory for the material and the type of cutting you plan to do.
 3. Never use grinding wheels, abrasive cut-off wire wheels or buffing wheel. They can fly apart explosively.

4. Choose and inspect your cutting tool carefully.
 - a. To avoid cutting tool failure and thrown shrapnel (broken pieces of blade), use only 10" or smaller blades or other cutting tools marked for speeds of 3450 rpm or higher.
 - b. Always use unbroken, balanced blades designed to fit this saw's 5/8" arbor.
 - c. When thru-sawing, (making cuts where the blade comes through the workpiece top) always use a 10 inch diameter blade. This keeps the spreader in closest to the blade.
 - d. Do not overtighten arbor nut. Use arbor wrenches to "snug" it securely.
 - e. Use only sharp blades with properly set teeth. Consult a professional blade sharpener when in doubt.
 - f. Keep blades clean of gum and resin.
5. Adjust table inserts flush with the table top. NEVER use the saw without the proper insert.
6. Make sure all clamps and locks are tight and no parts have any excessive play.

2. KEEP WORK AREA CLEAN

- a. Cluttered areas and benches invite accidents. Floor must not be slippery from wax or sawdust.
- b. To avoid burns or other fire damage, never use the saw near flammable liquids, vapors or gases.

Plan ahead to protect your eyes, hands, face, ears.

- a. To avoid injury from accidental blade contact, don't do layout, assembly, or setup work on the table while the blade is spinning. It could cut or throw anything hitting the blade.

AVOID ACCIDENTAL STARTING - Make sure switch is in "OFF" position before plugging saw in.

Plan your work

1. **USE THE RIGHT TOOL** - Don't force tool or attachment to do a job it was not designed for.
2. **Dress for safety:**
 - Do not wear loose clothing, gloves, neckties or jewelry (rings, wrist watches). They can get caught and draw you into moving parts.
 - Wear nonslip footwear.
 - Tie back long hair.
 - Roll long sleeves above the elbow.
 - Noise levels vary widely. To avoid possible hearing damage, wear ear plugs or muffs when using saw for long periods of time.

- Any power saw can throw foreign objects into the eyes. This can cause permanent eye damage. Wear safety **goggles (not glasses)** that comply with ANSI Z87.1 (shown on package). Everyday eyeglasses have only impact resistant lenses. They are not safety glasses. Safety goggles are available at Sears retail catalog stores. Glasses or goggles not in compliance with ANSI Z87.1 could seriously hurt you when they break.



- For dusty operations, wear a dust mask along with the safety goggles.
3. Inspect your workpiece. Make sure there are no nails or foreign objects in the part of the workpiece to be cut.
 4. Plan your cut to avoid **KICKBACKS** and **THROWBACKS** - when a part or all of the workpiece binds on the blade and is thrown violently back toward the front of the saw:
 - **Never cut FREEHAND:** Always use either a rip fence, miter gauge or fixture to position and guide the work, so it won't twist, bind on the blade and kickback.
 - Make sure there's no debris between the workpiece and its supports.
 - When cutting **irregularly shaped workpieces**, plan your work so it will not slip and pinch the blade.
 - A piece of molding, for example, must lie flat or be held by a fixture or jig that will not let it twist, rock or slip while being cut. Use jigs, fixtures where needed to prevent workpiece shifting.
 - Use a different, better suited type of tool for work that can't be made stable.
 - Use extra caution with large, very small or awkward workpieces:
 - Use extra supports (tables, saw horses, blocks, etc.) for any workpieces large enough to tip when not held down on the table top. **NEVER use another person** as a substitute for a table extension, or as additional support for a workpiece that is longer or wider than the basic saw table, or to help feed, support or pull the workpiece.

- Never confine the piece being cut off. That is, the piece NOT against the fence, miter gauge or fixture. Never hold it, clamp it, touch it, or use length stops against it. It must be free to move. If confined, it could get wedged against the blade and cause a kickback or throwback.
- Never cut more than one workpiece at a time.
- Never turn your table saw "ON" before clearing everything except the workpiece and related support devices off the table.

Plan the way you will push the workpiece through.

- **NEVER pull the workpiece through.** Start and finished the cut from the front of the table saw.
- **NEVER put your fingers or hands in the path of the sawblade or other cutting tool.**
- **NEVER reach in back of the cutting tool** with either hand to hold down or support the workpiece, remove wood scraps, or for any other reason.
- Avoid awkward operations and hand positions where a sudden slip could cause fingers or hand to move into a sawblade or other cutting tool.
- **DON'T OVERREACH.** Always keep good footing and balance.
- Push the workpiece against the rotation of the blade. **NEVER** feed material into the cutting tool from the rear of the saw.
- Always push the workpiece all the way past the sawblade.
- As much as possible, keep your face and body to one side of the sawblade, out of line with a possible kickback or throwback.
- **NEVER** turn the saw "ON" before clearing the table of all tools, wood scraps, etc., except the workpiece and related feed or support devices for the cut planned.

WHENEVER SAW IS RUNNING

WARNING: DON'T LET FAMILIARITY (GAINED FROM FREQUENT USE OF YOUR TABLE SAW) CAUSE A CARELESS MISTAKE. ALWAYS REMEMBER THAT A CARELESS FRACTION OF A SECOND IS ENOUGH TO CAUSE A SEVERE INJURY.

1. Before actually cutting with the saw, watch it while it runs for a short while. If it makes an unfamiliar noise or vibrates excessively, stop immediately. Turn the saw off. Unplug the saw. Do not restart until finding and correcting the problem.
2. Make sure the top of the arbor or cutting tool turns toward the front of the saw.
3. Set the cutting tool as low as possible for the cut you're planning.
4. **KEEP CHILDREN AWAY.** All visitors should be kept a safe distance from work. Make sure bystanders are clear of the saw and workpiece.
5. Let the blade reach full speed before cutting.
6. **DON'T FORCE TOOL.** It will do the job better and safer at its designed rate. Feed the workpiece into the blade only fast enough to let it cut without bogging down or binding.
7. Before freeing any jammed material:
 - a. Turn switch "OFF".
 - b. Unplug the saw.
 - c. Wait for all moving parts to stop.
 - d. Check blade, spreader and fence for proper alignment before starting, again.
8. To avoid throwback of small, cut off pieces:
 - a. Use the guard assembly.
 - b. To remove pieces trapped inside the guard:
 1. Turn saw off.
 2. Remove switch key.
 3. Unplug saw.
 4. Wait for blade to stop before lifting the guard.

BEFORE LEAVING THE SAW

1. Turn saw off.
2. Wait for blade to stop spinning.
3. Make workshop child-proof. Lock the shop. Disconnect master switches. Remove the yellow switch key. Store it away from children and others not qualified to use the tool.
4. Unplug the saw.

USING THE MITER GAUGE

The MITER GAUGE is used when **CROSSCUTTING, MITER CUTTING, BEVEL CUTTING, COMPOUND MITER CUTTING, DADOING** and when **RABBETTING AND MOLDING** across the end of a narrow workpiece.

WARNING: FOR YOUR OWN SAFETY, ALWAYS OBSERVE THE FOLLOWING SAFETY PRECAUTIONS IN ADDITION TO THE SAFETY INSTRUCTIONS ON PAGES 2, 3, 4, 5, 6, 26, 27, AND 28.

ADDITIONAL SAFETY INSTRUCTIONS FOR CROSS CUT TYPE CUTS

Before starting

- NEVER use the rip fence when crosscutting.

CROSSCUTTING

Crosscut

A cutting or shaping operation made across the width of the workpiece.

The graduations on the miter gauge provide accuracy for average woodworking. In some cases where extreme accuracy is required, when making angle cuts, for example, make a trial cut and then recheck it with an accurate square, or protractor.

If necessary, the miter gauge head can be swiveled slightly to compensate for any inaccuracy.

NOTE: The space between the miter gauge bar and the groove in the table is held to a minimum during manufacturing.

For maximum accuracy when using the miter gauge, always "favor" one side of the groove in the table. In other words, don't move the miter gauge from side to side while cutting, but keep one side of the bar riding against one side of the groove.

NOTE: Glue a piece of sandpaper to the face of the miter gauge head. This will help prevent the workpiece from "creeping" while it is being cut.

The Hold-Down Clamp (Optional Accessory) should be used on the miter gauge for greater accuracy.

The miter gauge may be used in either of the grooves in the table. Make sure it is locked.

WARNING: TO AVOID BLADE CONTACT, HOLD THE MITER GAUGE PROPERLY.

When using the miter gauge in the **LEFT** hand groove, hold the workpiece firmly against the miter gauge head with your left hand, and grip the lock handle with your right.

When using the **RIGHT** Hand groove, hold the workpiece with your right hand and the lock handle with your left hand.

When cutting long workpieces, insert **AUXILIARY FENCE/WORK SUPPORT** and position it on top of the guide bars to support the workpiece as near to the end as possible. If this does not adequately support the workpiece, you can make a simple support by clamping a piece of plywood to a sawhorse. See first illustration under "Crosscutting".

- An auxiliary wood facing attached to the miter gauge can help prevent workpiece twisting and throwbacks. Attach it to the holes provided. Make the facing long enough and big enough to support your work. Make sure, however, it will not interfere with the sawblade guard.
- Use jigs or fixtures to help hold any piece too small to extend across the full length of the miter gauge face during the cut. This lets you properly hold the miter gauge and workpiece and helps keep your hands away from the blade.

While cutting

- To avoid blade contact, always hold the miter gauge as shown in the **BASIC SAW OPERATIONS - USING THE MITER GAUGE**.

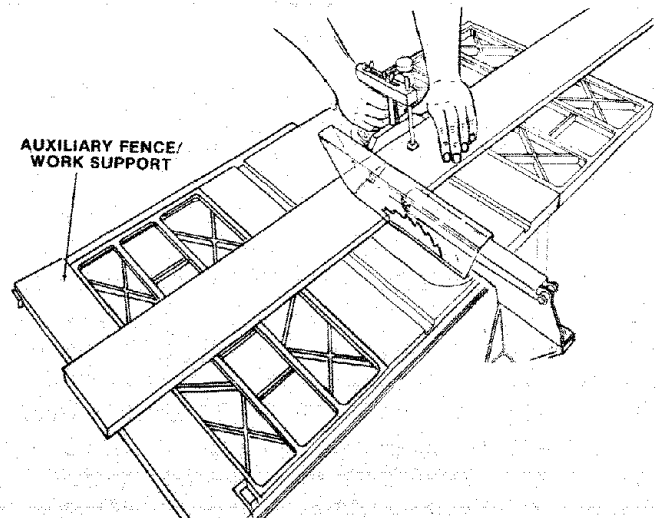
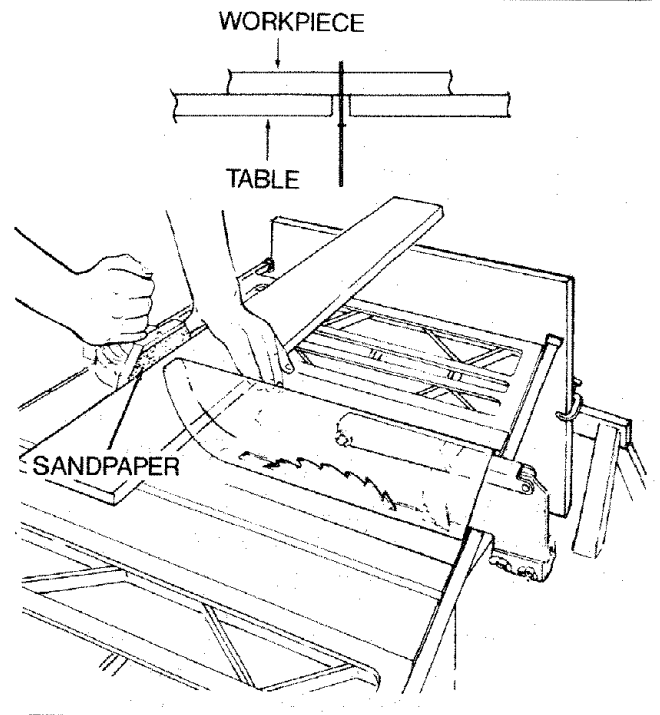

Use a Hold-Down Clamp (Optional Accessory) on the miter gauge for greater accuracy.

REPETITIVE CUTTING

REPETITIVE CUTTING is known as cutting a quantity of pieces the same length without having to mark each piece.

1. Use the Stop Rods (optional accessory) only for cutting duplicate pieces 6 in. long and longer.
2. Follow all safety precautions and operational instructions for cross cutting.

When making repetitive cuts from a long workpiece, make sure it is adequately supported.

Use the Hold-Down Clamp (Optional Accessory) on the miter gauge for greater accuracy.

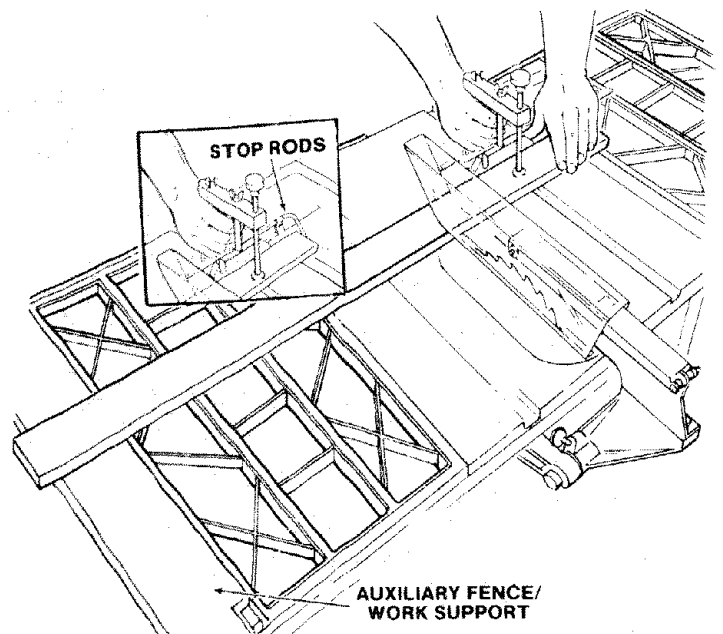

1. NEVER USE THE RIP FENCE AS A LENGTH STOP BECAUSE THE CUT OFF PIECE COULD BIND BETWEEN THE FENCE AND THE BLADE CAUSING A KICKBACK.

2. When making repetitive cuts shorter than 6 in., clamp a block of wood 2 in. long to the table to act as a length stop. Do not clamp directly to the bottom edge of the table because the swivel of the clamp will not grip properly. Place a small block of wood between the bottom edge of the table and the "C" clamp.

CAUTION: When clamping the block, make sure that the end of the block is well in front of the sawblade. Be sure it is clamped securely.

3. Slide the workpiece along the miter gauge until it touches the block. . . hold it securely or clamp it with the Hold-Down Clamp (Optional Accessory).

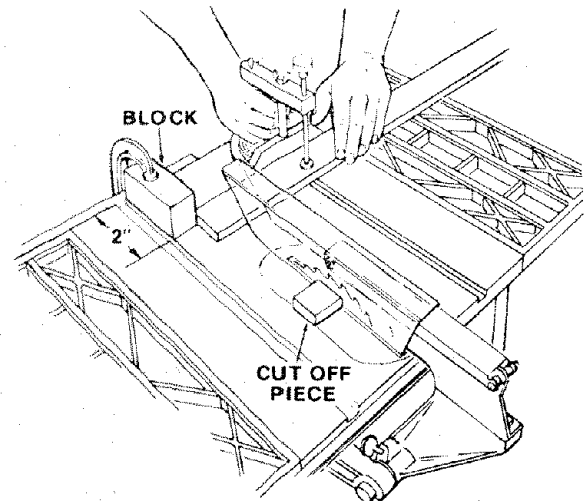

4. Make the cut . . . turn the saw off . . . remove the piece after the blade has stopped and before cutting the next piece.

MITER CUTTING

MITER CUTTING is known as cutting wood at an angle other than 90° with the edge of the wood. Follow the same procedure as you would for cross-cutting.

Adjust the miter gauge to the desired angle, and lock it.

The miter gauge may be used in either of the grooves in the table.

When using the miter gauge in the LEFT hand groove, hold the workpiece firmly against the miter gauge head with your left hand, and grip the lock handle with your right.

When using the RIGHT hand groove, hold the workpiece with your right hand and the knob with your left hand.

Use the Hold-Down Clamp (Optional Accessory) on the miter gauge for greater accuracy.

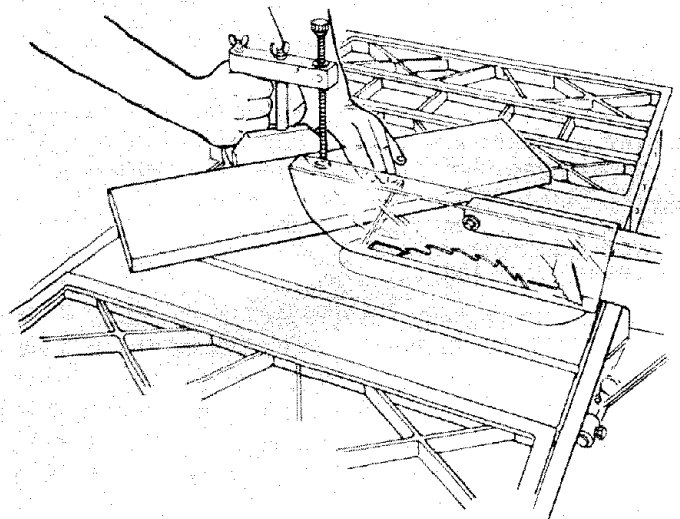

BEVEL CROSSCUTTING

BEVEL CROSSCUTTING is the same as crosscutting except that the wood is also cut at an angle . . . other than 90° with the flat side of the wood.

Adjust the blade to the desired angle.

Use the Miter Gauge in the groove to the RIGHT of the blade. It cannot be used in the groove to the LEFT because the blade guard will interfere. Hold the workpiece with your right hand and the lock-handle with your left hand.

Use the AUXILIARY FENCE/WORK SUPPORT for additional support of the workpiece.

Lay it across the guide bars to support the workpiece as near to the end as possible.

Use the Hold-Down Clamp (Optional Accessory) on the miter gauge for greater accuracy.

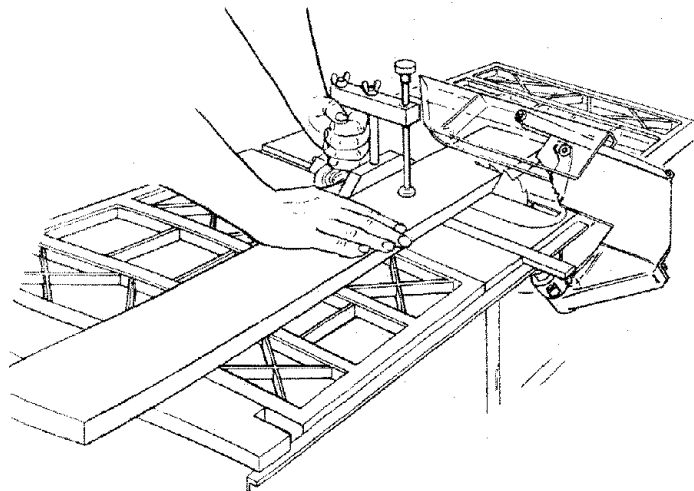

COMPOUND MITER CUTTING

COMPOUND MITER CUTTING is a combination of miter cutting and bevel crosscutting. The cut is made at an angle other than 90° to both the edge and the flat side of the wood.

Adjust the miter gauge and the blade to the desired angle . . . Make sure miter gauge is locked.

USING THE RIP FENCE

RIPPING, BEVEL RIPPING, PLOUGHING, MOLDING, RESAWING AND RABBETTING are performed using the RIP FENCE together with the AUXILIARY FENCE/WORK SUPPORT, PUSH STICK OR PUSH BLOCK.

WARNING: FOR YOUR OWN SAFETY, ALWAYS OBSERVE THE FOLLOWING SAFETY PRECAUTIONS IN ADDITION TO THE SAFETY INSTRUCTIONS ON PAGES 2, 3, 4, 5, 6, 26, 27, AND 28.

ADDITIONAL SAFETY INSTRUCTIONS FOR RIP TYPE CUTS

- NEVER use the miter gauge when ripping.
- Use a push stick whenever the fence is 2 to 6 inches from the blade. Use an auxiliary fence and push block whenever the fence must be within 2 inches of the blade. (See "Basic Saw Operation Using The Rip Fence" section.)
- When using a push stick or push block, the trailing end of the board must be square. A push stick or block against an uneven end could slip off or push the work away from the fence.
- Never rip anything shorter than 10" long.

- A **FEATHERBOARD** can help guide the workpiece.

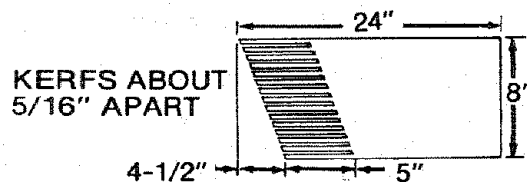

Before starting

- To avoid kickbacks and slips into the blade, make sure the rip fence is parallel to the sawblade.
- Check the antikickback pawls. (See **BASIC SAW OPERATION - USING THE RIP FENCE.**) The pawls must stop a kickback once it has started. Replace or sharpen antikickback pawls when points become dull.
- Plastic and composition (like hardboard) materials may be cut on your saw. However, since these are usually quite hard and slippery, the antikickback pawls may not stop a kickback. Therefore, be especially careful in your set-up and cutting procedures.

While cutting

- To avoid kickbacks and slips into the blade, always push forward on the section of the workpiece between the saw blade and the rip fence. Never push forward on the piece being cut off.

RIPPING

Ripping

A cutting operation along the length of the workpiece.

Position the fence to the desired WIDTH OF RIP and lock in place.

Before starting to rip, be sure

- A. Rip Fence is parallel to sawblade.
- B. Spreader is properly aligned with sawblade.
- C. Antikickback pawls are functioning properly.

When ripping LONG BOARDS or LARGE PANELS, always use a work support.

A simple one can be made by clamping a piece of plywood to a sawhorse.

BEVEL RIPPING NARROW WORK

When bevel ripping material 6 in. or narrower, use fence on the right side of the blade **ONLY**. This will provide more space between the fence and the sawblade for use of a push stick. If the fence is mounted to the left, the sawblade guard may interfere with proper use of a push stick.

ALWAYS SUPPORT LONG WORKPIECES

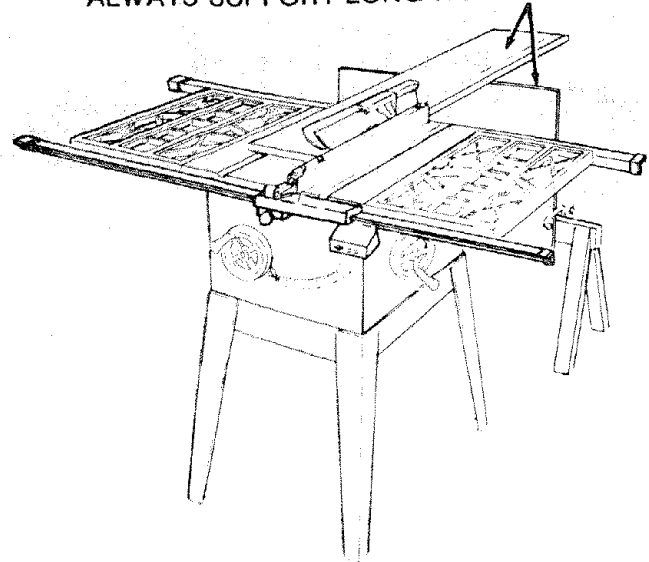

USING FEATHERBOARDS FOR THRU-SAWING

Featherboards are **not** employed for thru-sawing operations when using the miter gauge.

Featherboards are used to keep the work in contact with the fence and table as shown, and to help stop kickbacks.

Add 7-1/2 inch high flat facing board to the fence, the full length of the fence.

Mount featherboards to fence and table as shown, so that leading edges of featherboards will support workpiece.

WARNING: MAKE SURE THE FEATHERBOARD AGAINST THE EDGE PRESSES ONLY ON THE UNCUT PORTION (FORWARD OF THE BLADE). IT MIGHT OTHERWISE PINCH THE BLADE IN THE KERF AND CAUSE A KICKBACK.

Before starting the operation (switch "OFF" and cutter below table surface):

- (a) Install featherboards so they exert pressure on the workpiece; be positive they are secure, and
- (b) Make sure by trial that the featherboards will stop a kickback if one should occur.

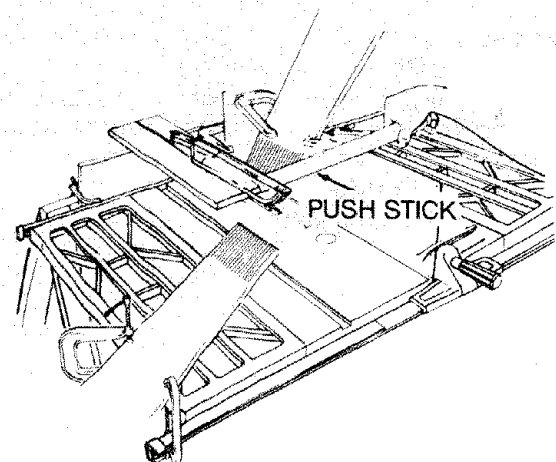
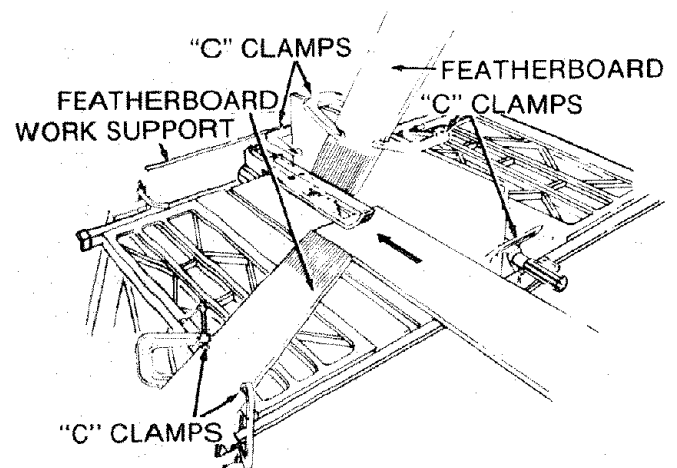

When "WIDTH OF RIP" is 6 in. and WIDER use your RIGHT Hand to feed the workpiece until it is clear of the table.

Use LEFT hand ONLY to guide the workpiece . . . do not FEED the workpiece with the left hand.

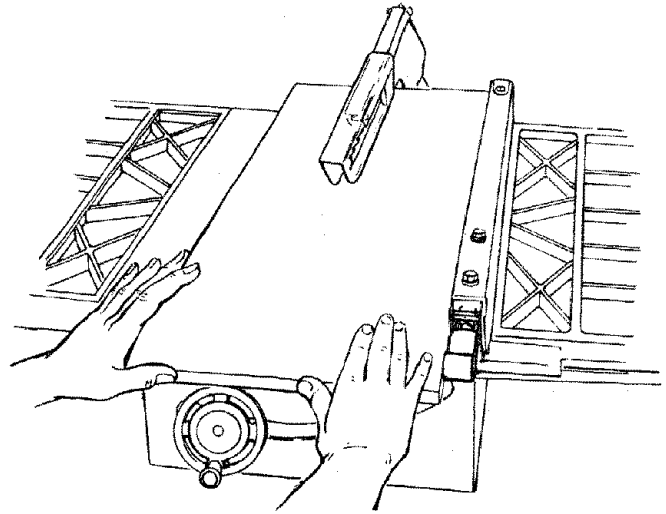

When "WIDTH OF RIP" is 2 in. to 6 in. wide USE THE PUSH STICK to feed the work.

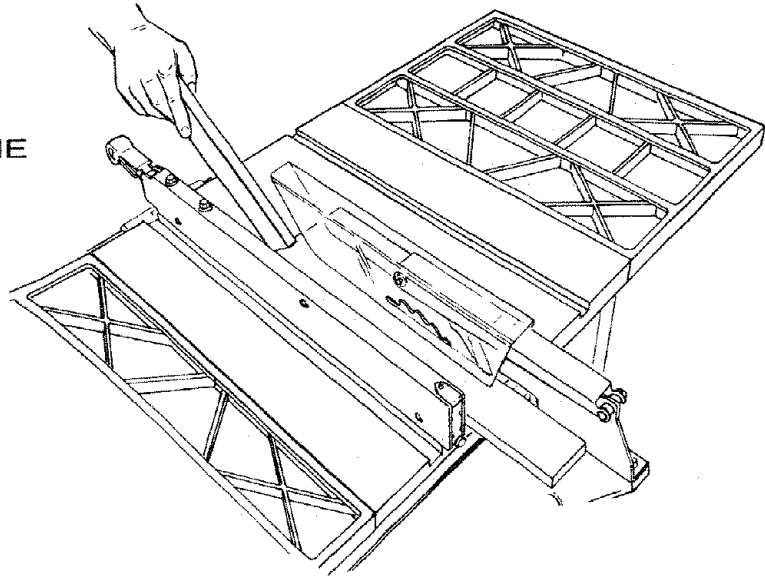

When WIDTH OF RIP is NARROWER than 2 in., the push stick CANNOT be used because the guard will interfere . . . USE the AUXILIARY FENCE/WORK SUPPORT and PUSH BLOCK.

Attach Auxiliary Fence/Work Support to rip fence with two "C" clamps.

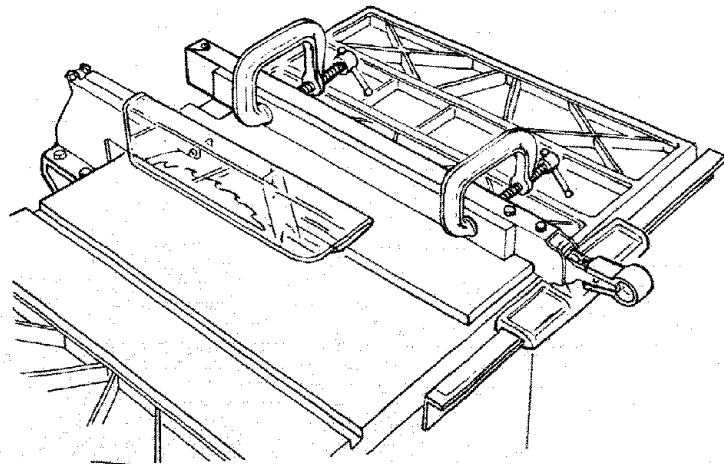

Feed the workpiece by hand along the AUXILIARY FENCE until the end is approx. 1 in. past the front edge of the table. Continue to feed using the PUSH BLOCK.

Hold the workpiece in position and install the PUSH BLOCK by sliding it on top of the AUXILIARY FENCE/WORK SUPPORT (This May Raise Guard).

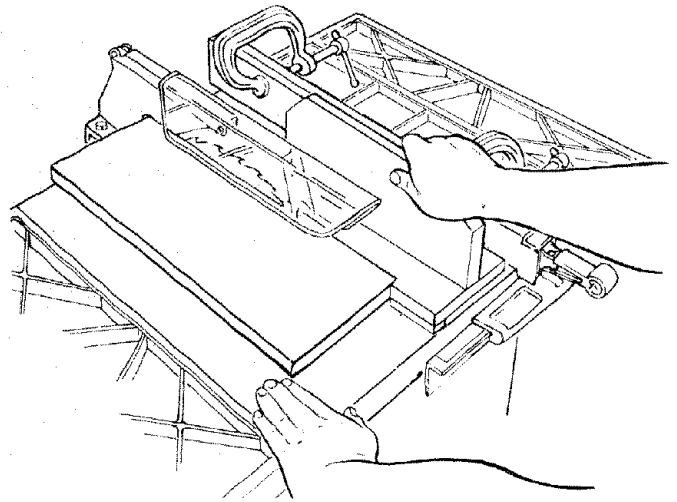

Narrow strips thicker than the Auxiliary Fence/Work Support may enter the guard and strike the baffle. CAREFULLY raise guard only enough to clear the workpiece. Use PUSH BLOCK to complete cut.

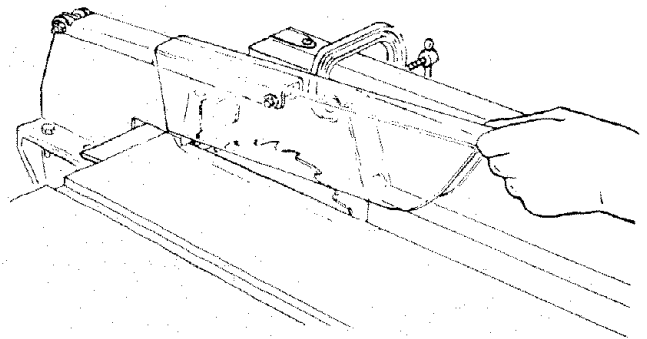
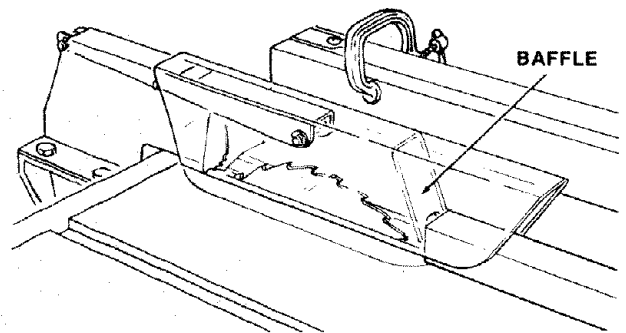

RESAWING

RESAWING is known as ripping a piece of wood through its thickness. Do not attempt to resaw BOWED or WARPED material. NOTE: To RESAW a piece of wood wider than 3-3/8 inch . . . it will be necessary to remove the blade guard . . . and use the AUXILIARY FENCE/WORK SUPPORT (See "Work Helpers").

Clamp it to the table so that the workpiece will SLIDE EASILY but not TILT or MOVE SIDEWAYS without BINDING between the two fences.

Do not clamp directly to the bottom edge of the table because the "swivel" of the clamp will not grip properly. Place a small block of wood between the bottom edge of the table and the "C" clamp.

WARNING: FOR YOUR OWN SAFETY . . .

1. DO NOT "BACK UP" (REVERSE FEED)

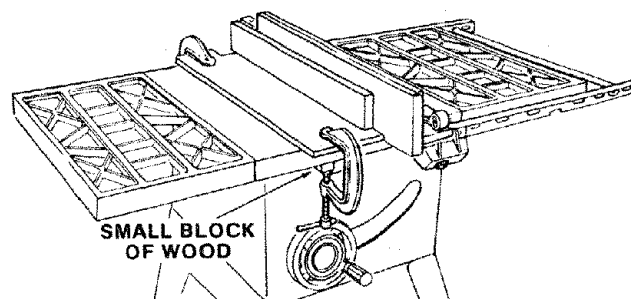

2. MAKE FIRST PASS TO A DEPTH SLIGHTLY LESS THAN ONE-HALF THE WIDTH OF THE BOARD KEEP SAME FACE OF BOARD AGAINST FENCE FOR SECOND PASS AS THE FIRST PASS.

3. INSTALL BLADE GUARD IMMEDIATELY UPON COMPLETION OF THE RESAWING OPERATION

CUTTING PANELS

When cutting panels (whenever fence is positioned outside of table surface), ALWAYS use the AUXILIARY PANEL/WORK SUPPORT.

1. Unlock fence and raise rear end.
2. Position AUXILIARY FENCE/WORK SUPPORT as shown and attach it with two "C" clamps.

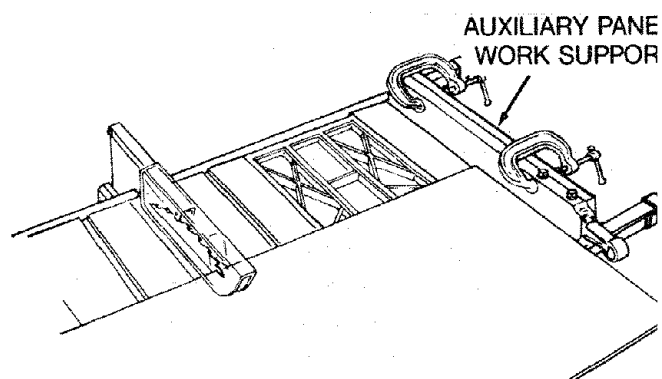

USING FEATHERBOARDS FOR NON-THRU SAWING

Featherboards are **not** employed during non thru-sawing operations when using the miter gauge.

Use featherboards for all other non "thru-sawing" operations (when sawblade guard must be removed). Featherboards are used to keep the work in contact with the fence and table as shown, and to stop kickbacks.

Add 7-1/2 inch high flat facing board to the fence, the full length of the fence.

Mount featherboards to fence and table as shown, so that leading edges of featherboards will support workpiece until cut is complete, and the workpiece

has been pushed completely past the cutter (sawblade, dado head, molding head, etc.) with a pushstick, as in ripping.

Before starting the operation (switch "OFF" and cutter below table surface):

- (a) Install featherboards so they exert pressure on the workpiece; be positive they are secure, and
- (b) Make sure by trial that the featherboards will stop a kickback if one should occur.

Replace the sawblade guard as soon as the non thru-sawing operation is complete.

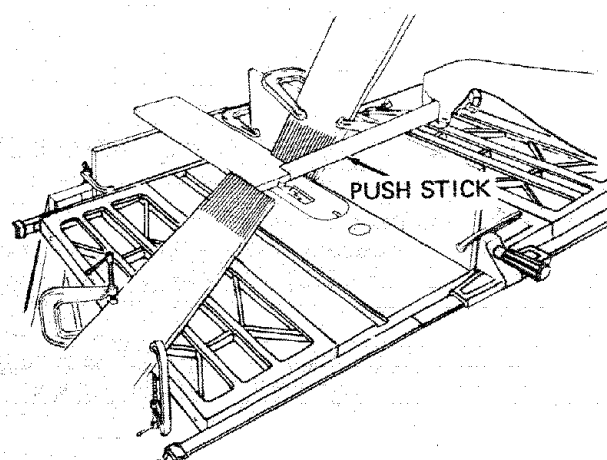
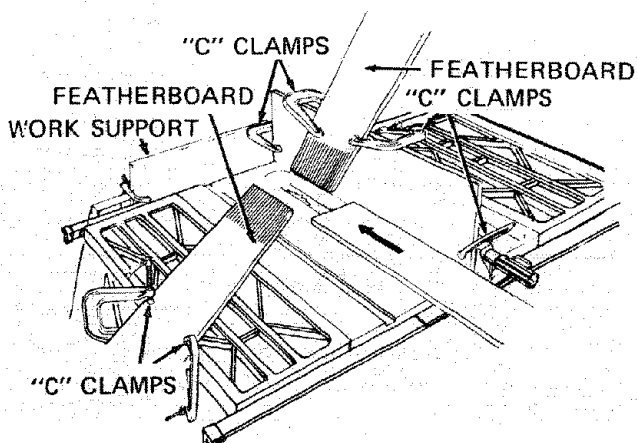

RABBETING

RABBETING is known as cutting out a section of the corner of a piece of material, across an end or along an edge.

To make a RABBET requires cuts which do not go all the way through the material. Therefore the blade guard must be removed.

1. Remove blade guard.
2. **For rabbeting along an edge** (long way of workpiece) as shown, add facing to rip fence approximately as high as the workpiece is wide. Adjust rip fence and blade to required dimensions; then make first cut with board flat on table as any rip (type) cut; make second cut with workpiece on edge. Follow all precautions, safety instructions, and operational instructions as for ripping, or rip type operations, including feather boards and push stick, etc.
3. **For rabbeting across an end**, for workpiece 10-1/2" and narrower make the rabbet cut with the board flat on the table. Using the miter gauge fitted with a facing, follow the same procedures and instructions for cross cutting making successive cuts across the width of the workpiece to obtain the desired width of cut. **DO NOT** use the rip fence for rabbeting across the end.
4. **INSTALL BLADE GUARD IMMEDIATELY UPON COMPLETION OF RABBETING OPERATION.**

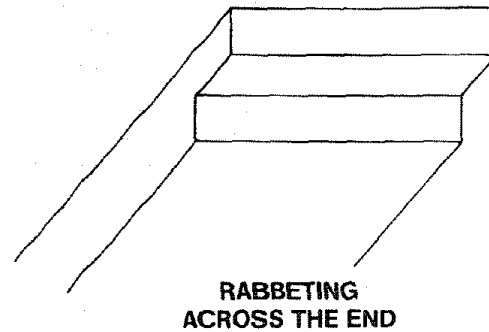
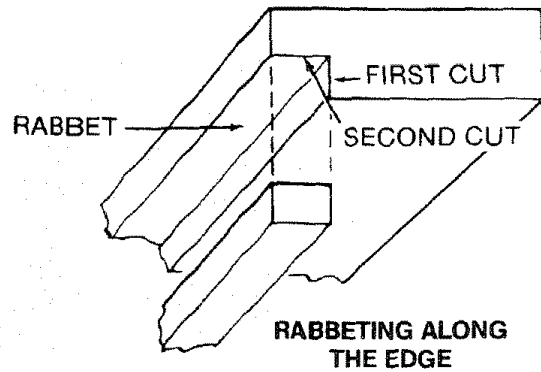

Rabbet cuts can also be made in one pass of the workpiece over the cutter using the dado head or molding head.

PLOUGHING AND MOLDING

PLOUGHING is grooving with the grain the long way of the workpiece, using the fence. **USE** featherboards and push sticks as required.

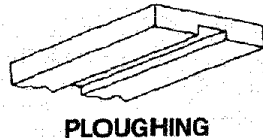

MOLDING is shaping the workpiece with the grain the long way of the workpiece, using the fence. Use featherboards and push sticks as required.

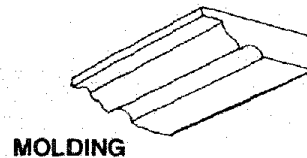

DADOING

Instructions for operating the Dado Head are contained in booklet furnished with the Dado Head.

The Recommended Dado Head is listed under Recommended Accessories in this manual.

The arbor on the saw, is only long enough so that the widest cut that can be made is 13/16" wide.

It is not necessary to install the outside loose collar before screwing on the arbor nut. Make sure the arbor nut is tight.

ALWAYS USE DADO INSERT LISTED UNDER RECOMMENDED ACCESSORIES.

When using the dado head, it will be necessary to remove the Blade Guard and Spreader. Using MITER GAUGE, FENCE, FEATHERBOARDS, and PUSH STICK, etc. as required.

ALWAYS REPLACE THE BLADE, GUARD AND SPREADER WHEN YOU ARE FINISHED DADOING.

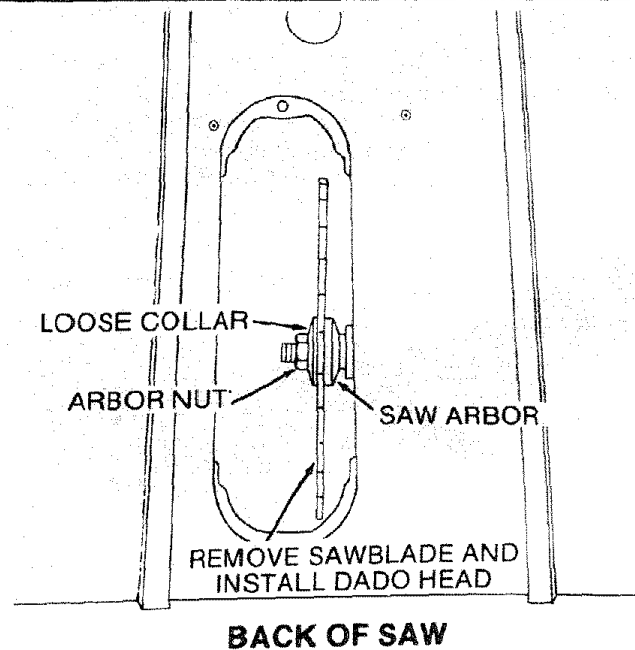

MOLDING CUTTING

Instructions for operating the Molding Head are contained in a booklet furnished with the Molding Head.

The recommended molding head is listed under Recommended Accessories in this manual.

Always use Molding Insert listed under Recommended Accessories.

When using the molding head, it will be necessary to remove the Blade Guard and Spreader. USE CAUTION. USE MITER GAUGE, FENCE, FEATHERBOARDS, AND PUSH STICK, ETC., AS REQUIRED.

ALWAYS REPLACE THE BLADE GUARD AND SPREADER WHEN YOU ARE FINISHED MOLDING.

ADJUSTMENTS

WARNING: FOR YOUR OWN SAFETY, TURN SWITCH "OFF" AND REMOVE PLUG FROM POWER SOURCE OUTLET BEFORE MAKING ANY ADJUSTMENTS.

MITER GAUGE

NOTE: The slots for the stop pin and the graduations are manufactured to very close tolerances which provide accuracy for average woodworking. In some cases where extreme accuracy is required, when making angle cuts, for example, make a trial cut and then recheck it.

If necessary, the miter gauge head can be swiveled slightly to compensate for any inaccuracy.

1. Loosen the "knob" and pull "stop pin" OUT.
2. Swivel the head . . . position it at "0" . . . push the stop pin IN . . . lock the handle.
3. The HEAD should be square with the Bar and the pointer should point to "0". Readjust the pointer if necessary.
4. If the head is not square with the bar, adjustments are required.
 - A. Loosen the "knob" (1) and the "two screws" (2).
 - B. Position the HEAD square with the BAR using a combination square.
 - C. PUSH the STOP PIN into the slot in the head at "0" . . . push the pin into the slot and twist it. Lock the knob.
 - D. Recheck with the square. If the head is still not square, loosen the screws (2) and readjust the INDICATOR BLOCK.
 - E. With the head square with the bar and the pin pushed into the slot adjust the pointer (3) to point to "0".
 - F. The miter gauge head must rest on top of the bar without being able to move up and down . . . yet it must swivel freely.
 - G. The swiveling movement of the head can be adjusted by tightening or loosening the set-screw (4) . . . using the 1/8 in. setscrew wrench.

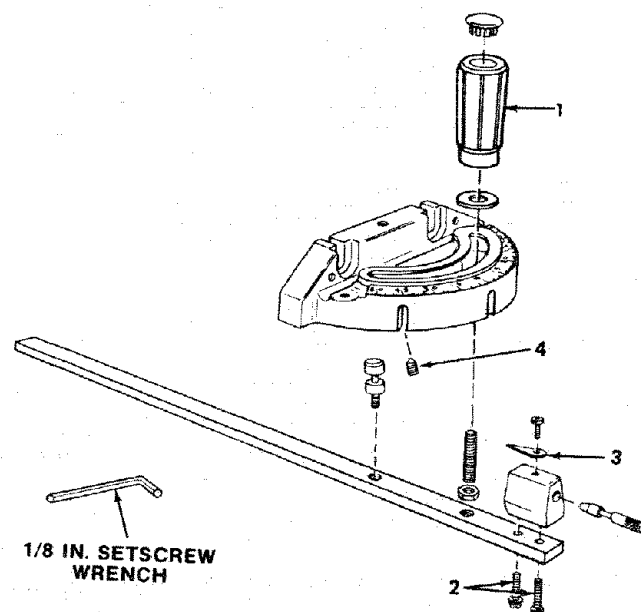
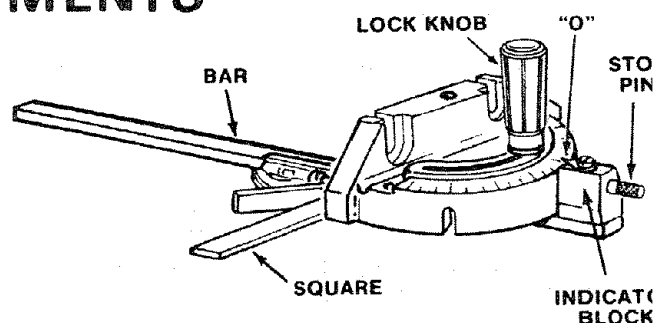

NOTE: The setscrew is located inside of the head. To reach it, swivel the head to 60 degrees and turn the miter gauge upside down.

HEELING ADJUSTMENT or PARALLELISM OF SAWBLADE TO MITER GAUGE GROOVE

While cutting, the material must move in a straight line PARALLEL to the SAWBLADE ... therefore both the miter gauge GROOVE and the RIP FENCE must be PARALLEL to the SAWBLADE.

If the sawblade IS NOT parallel to the miter gauge groove, the blade will bind at one end of the cut. (This is known as "HEELING").

To check for parallelism:

WARNING — FOR YOUR OWN SAFETY, TURN SWITCH "OFF" AND REMOVE PLUG FROM POWER SOURCE OUTLET.

1. Raise blade all the way up ... raise blade guard.
2. Mark an "x" on one of the teeth which is SET (bent) to the LEFT.
3. Place the head of a combination square in the GROOVE ... adjust blade of square so that it just touches the tip of the MARKED tooth.
4. Move square to REAR, rotate blade to see if MARKED tooth again touches blade of square.

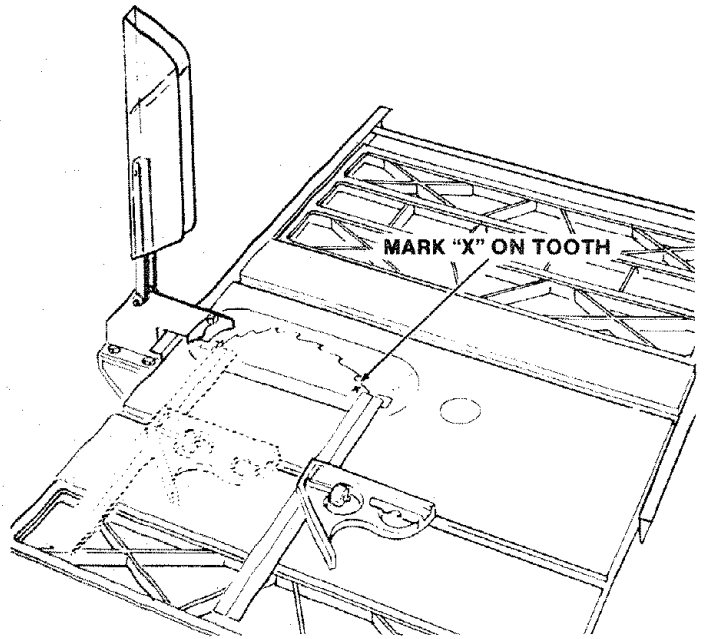

5. If tooth touches square at FRONT and REAR ... sawblade is PARALLEL to MITER GAUGE GROOVE.

6. If tooth does not touch the same amount ... the mechanism underneath must be adjusted to make the blade PARALLEL to GROOVE.
 - A. Rear trunnion must be moved TOWARD the combination square if there is a space between marked tooth and end of square in step 4.
 - B. Rear trunnion must be moved AWAY from the square if marked tooth pushes square out of position in the groove.

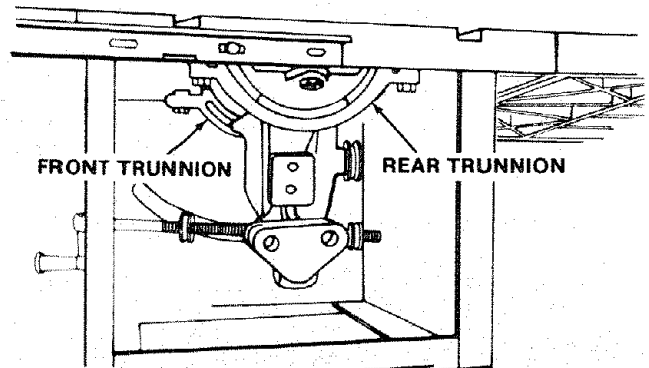

7. Loosen all three screws that hold the rear trunnion and all three screws that hold the front trunnion.

NOTE: All six screws can be reached through back of saw. Use a 9/16 in. wrench. To reach left-hand front trunnion screw, tilt blade to 45°. After loosening screws reposition blade at 90°.

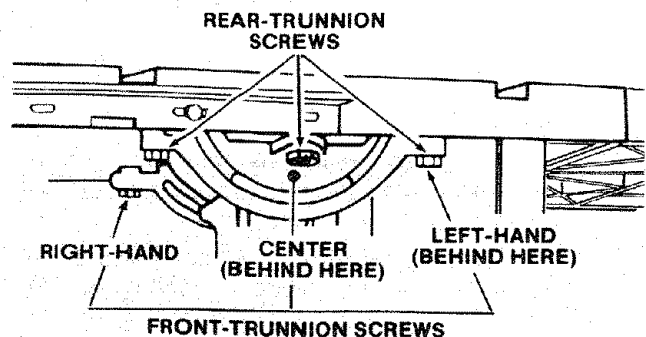

8. Using a wood block and mallet as shown, move rear trunnion to right or left as required to realign the blade. If necessary, shift front trunnion in similar manner; but do NOT move front trunnion unless necessary. Recheck the alignment with the square, then securely retighten all six trunnion screws.

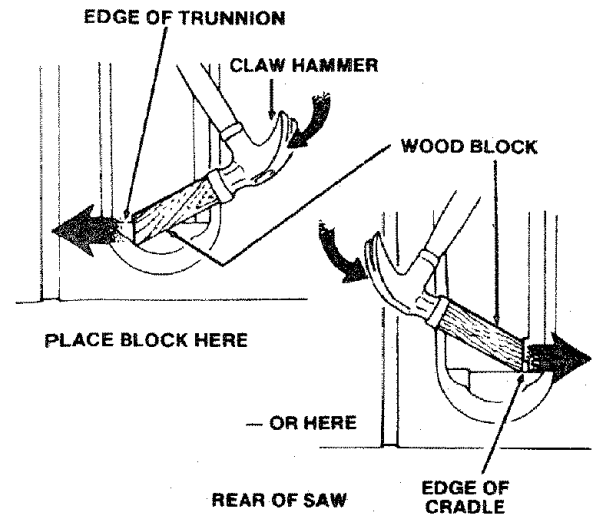

BLADE TILT, OR SQUARENESS OF BLADE TO TABLE

90° (SQUARE) and 45° (BEVEL) STOP COLLARS. When the bevel pointer is pointing directly to the "0" mark on the bevel scale, the sawblade should make a SQUARE cut 90° to the table.

To check for SQUARENESS:

WARNING: FOR YOUR OWN SAFETY, TURN SWITCH "OFF" AND REMOVE PLUG FROM POWER SOURCE OUTLET.

1. Raise blade all the way UP . . . raise blade guard.
2. TILT blade a few degrees to the LEFT . . . now tilt blade back to the RIGHT as far as it will go.
3. Place the square against blade. Make sure square is not touching the TIP of one of the saw TEETH.

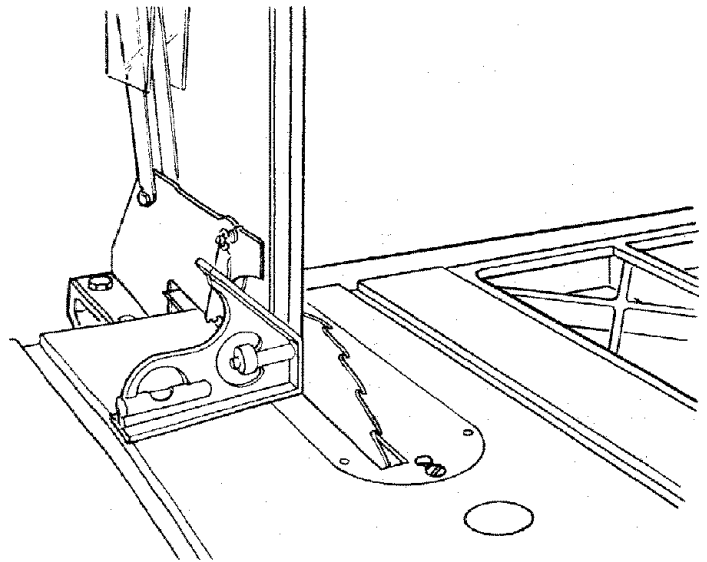

4. Operate the tilt-lock handle (COUNTER-CLOCKWISE) to loosen the tilt clamp screw.
5. **NOTE:** Handle is spring loaded for engagement with screw head - must be pushed inward for disengagement whenever necessary to obtain a new grip on screw head.

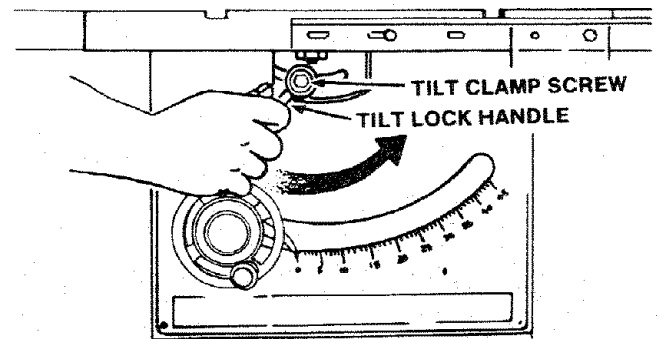

6. Rotate tilt handwheel CLOCKWISE a few turns to tilt blade. Now rotate handwheel COUNTERCLOCKWISE until it stops. Blade should now be square with table and pointer should point to "0".

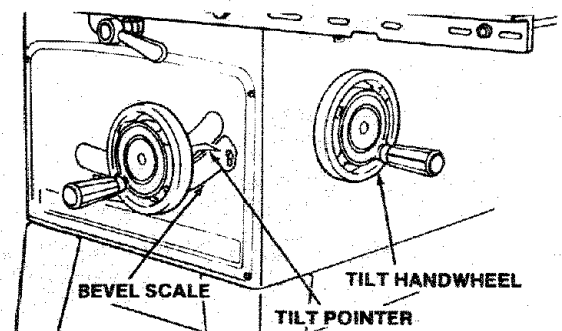

If blade is SQUARE to table;

A. Check pointer

IF POINTER DOES NOT point to the "0" mark on the bevel scale;

A. Remove Elevation Handwheel.

B. Loosen screw and adjust pointer . . . using medium screwdriver.

C. Install Elevation Handwheel.

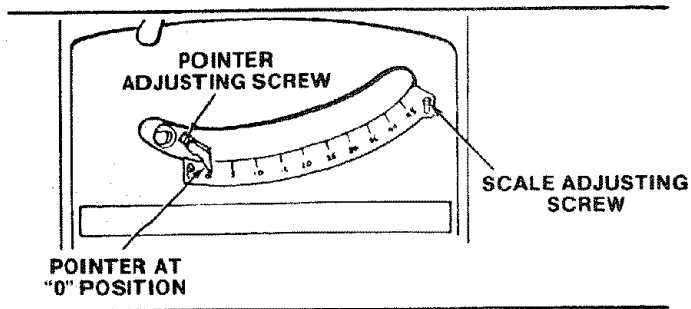

If blade is NOT SQUARE to table . . . the 90° LIMIT STOP must be ADJUSTED.

1. Using a medium size screwdriver, loosen BOTH setscrews in 90° STOP COLLAR.

NOTE: If you can't reach the setscrews, turn the TILT HANDWHEEL slightly.

2. ROTATE the STOP COLLAR moving it all the way to the end of TILT SCREW (to the right).

3. TILT blade RIGHT or LEFT . . . checking with your square until blade is square to table.

4. ROTATE STOP COLLAR moving it to the right until it stops . . . TIGHTEN the setscrews.

5. Check POINTER. If it DOES NOT point to the "0" mark on the bevel scale . . .

A. Remove Elevation Handwheel.

B. Loosen screw and adjust pointer . . . using medium screwdriver.

C. Install Elevation Handwheel.

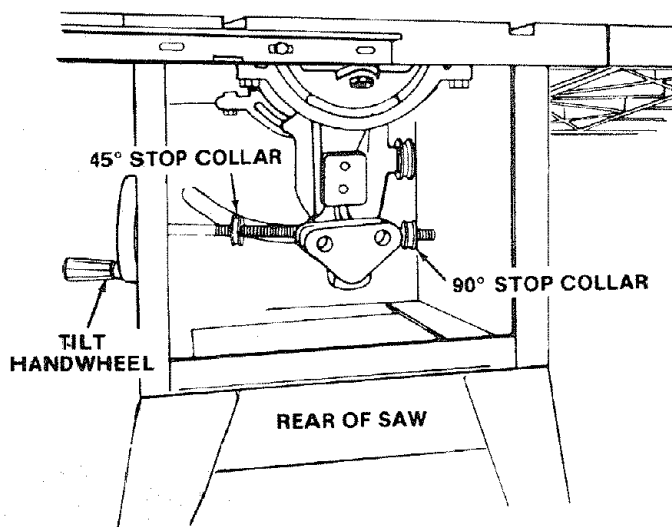

45° POSITION

TILT blade to LEFT as far as it will go. It will stop when the PIVOT NUT is against the 45° STOP COLLAR.

A. Place an ACCURATE square against blade. Make sure square is not touching the TIP of one of the saw TEETH.

If blade is 45° to table;

A. Check pointer.

IF POINTER DOES NOT point to the 45° mark on the scale;

A. Remove Elevation Handwheel.

B. Loosen two screws on scale and adjust scale until POINTER points to 45° mark.

C. Install Elevation Handwheel.

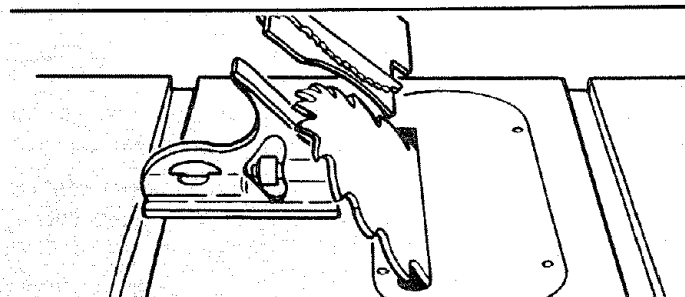

If blade is NOT 45° STOP COLLAR and SCALE must be ADJUSTED.

1. Remove Elevation Handwheel.
2. Using a small size screwdriver, reach thru curved slot in front trim panel and loosen BOTH setscrews in 45° STOP COLLAR.

NOTE: If you can't reach the setscrews, turn the TILT HANDWHEEL slightly.

3. ROTATE the STOP COLLAR moving it IN or OUT and TILT blade RIGHT or LEFT . . . checking with your square until blade is 45° to table.

4. TIGHTEN the setscrews.

NOTE: If you can't reach the setscrews, turn TILT HANDWHEEL slightly.

5. Loosen two screws on scale and adjust scale until POINTER points to 45° mark.

6. Install Elevation Handwheel.

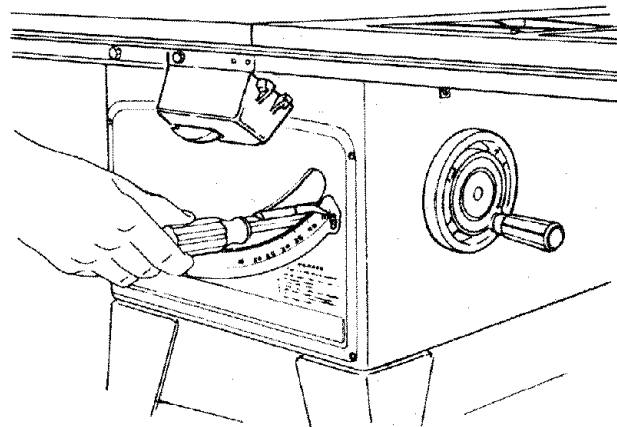

TILT MECHANISM

The handwheel should turn freely without binding. The turning action can be adjusted by tightening or loosening the screws in the bearing retainer.

NOTE: Tilt Handwheel must be removed to adjust. When adjusting the screws in the bearing retainer, hold the nut inside using a 3/8 in. wrench.

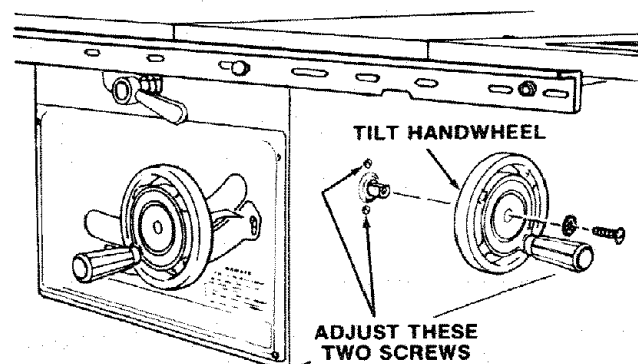

MAINTENANCE

WARNING: FOR YOUR OWN SAFETY, TURN SWITCH "OFF" AND REMOVE PLUG FROM POWER SOURCE OUTLET BEFORE MAINTAINING OR LUBRICATING YOUR SAW.

Do not allow sawdust to accumulate inside the saw.

Frequently blow out any dust that may accumulate inside the saw cabinet and the motor.

Frequently clean your cutting tools with Craftsman Gum and Pitch Remover.

A coat of automobile-type wax applied to the table will help to keep the surface clean and allow workpieces to slide more freely.

If the power cord is worn or cut, or damaged in any way, have it replaced immediately.

Make sure the teeth of the ANTIKICKBACK pawls are always sharp. To sharpen:

1. Remove blade guard.

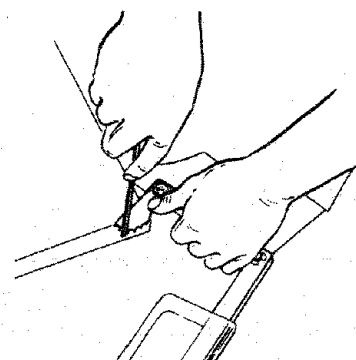

2. Rotate pawl toward rear of spreader so that teeth are above top of spreader.
3. Hold spreader with left hand and place pawl over corner of workbench.
4. Using a small round file (Smooth Cut) sharpen the teeth.

LUBRICATION

The following parts should be oiled occasionally with SAE No. 20 or No. 30 engine oil.

1. Tilt screw threads and pivot nut. (First Clean with Craftsman Gum & Pitch Remover.)
2. Elevation screw threads and pivot nut. (First Clean with Craftsman Gum & Pitch Remover.)
3. Cradle bearing points.
4. Bearing points in guard assembly, miter gauge and rip fence.

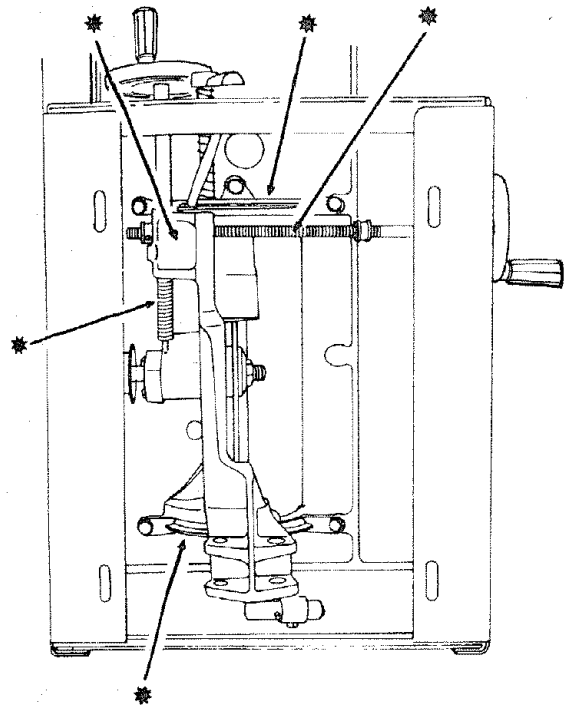
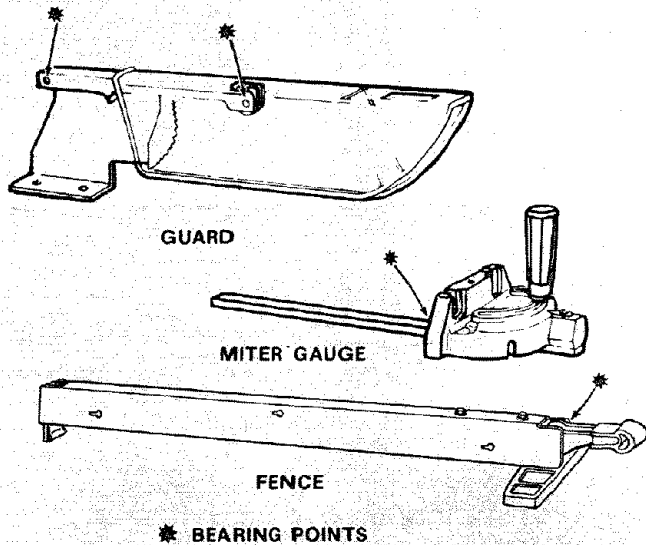

SEARS RECOMMENDS THE FOLLOWING ACCESSORIES

ITEM	CAT. NO.
Caster Set	9-22221
Caster Set	9-22222
7 In. Molding Head Set	9-3217
7 In. Molding Head Set	9-3218
7 In. Molding Head	9-3214
8 In. Dado	9-32708
Molding/Dado Insert for 7 In. Dia. Molding or Dado Head	9-29997
Molding/Dado Insert for 8 In. Dia. Molding or Dado Head	9-22287
Work Light	9-2480
Work Light	9-2481

ITEM	CAT. NO.
7 In. Dia. Adjustable Dado Head	9-3263
7 In. Dia. Dado Head	9-3257
Sanding Wheel	9-22723
Miter-Gauge Stop Rods	9-29924
Miter-Gauge Hold-Down Clamp	9-29928
Taper Jig	9-3233
Universal Jig	9-3231
Power Tool Know How Handbooks Table Saw	9-2918

Sears may recommend other accessories not listed in the manual. See your nearest Sears store or Catalog department for other accessories. Do not use any accessory unless you have received and read complete instructions for its use.

TROUBLE SHOOTING

WARNING: FOR YOUR OWN SAFETY, TURN SWITCH "OFF" AND ALWAYS REMOVE PLUG FROM POWER SOURCE OUTLET BEFORE TROUBLESHOOTING.

TROUBLE SHOOTING -- GENERAL

TROUBLE	PROBABLE CAUSE	REMEDY
Excessive vibration.	1. Blade out of balance.	1. Discard Blade and use a different blade.
Cannot make square Cut when crosscutting.	1. Miter gauge not adjusted properly.	1. See "Adjustments" section "Miter Gauge."
Cut binds, burns or stalls motor when ripping.	1. Dull blade with improper tooth set. 2. Blade is Heeling. 3. Warped board. 4. Rip fence not parallel to blade. 5. Spreader out of alignment	1. Sharpen or replace blade. 2. See "Adjustments" section, "Heeling Adjustment . . ." 3. Make sure concave or hollow side is facing "down," feed slowly. 4. See "Assembly" section, "Aligning Rip Fence" 5. See "Assembly" section, "Installing Blade Guard."
Cut not true at 90° or 45° positions.	1. Stop collars not properly adjusted.	1. See "Adjustments" section, "Blade Tilt, or "Squareness of Blade to Table."
Tilt and elevating handwheel turn hard.	1. Sawdust on threads of tilt screw or elevating screw. 2. Bearing retainers to tight.	1. See "Maintenance and Lubrication" section. 2. See "Maintenance" section "Tilt and Elevation Mechanism."

TROUBLE SHOOTING -- MOTOR

NOTE: Motors used on wood-working tools are particularly susceptible to the accumulation of sawdust and wood chips and should be blown out or "vacuumed" frequently to prevent interference with normal motor ventilation.

TROUBLE	PROBABLE CAUSE	REMEDY
Excessive noise.	1. Motor.	1. Have motor checked by qualified service technician. Repair service is available at your nearest Sears store.
Motor fails to develop full power. (Power output of motor decreases rapidly with decrease in voltage at motor terminals. For example, a reduction of 10% in voltage causes a reduction of 19% in maximum power output of which the motor is capable, while a reduction of 20% in voltage causes a reduction of 36% in maximum power output.)	1. Circuit overloaded with lights, appliances and other motors. 2. Undersize wires or circuit too long. 3. General overloading of power company facilities. (In some sections of the country, demand for electrical power may exceed the capacity of existing generating and distribution systems.) 4. Incorrect fuses or circuit breakers in power line.	1. Do not use other appliances or motors on same circuit when using the saw. 2. Increase wire sizes, or reduce length of wiring. See "Motor Specification and Electrical Requirements" section. 3. Request a voltage check from the power company. 4. Install correct fuses or circuit breakers.

TROUBLE SHOOTING -- MOTOR (Continued)

TROUBLE	PROBABLE CAUSE	REMEDY
Motor starts slowly or fails to come up to full speed.	<ol style="list-style-type: none"> 1. Low voltage will not trip relay. 2. Windings burned out or open. 3. Starting relay not operating. 	<ol style="list-style-type: none"> 1. Request voltage check from the power company. 2. Have motor repaired or replaced. 3. Have relay replaced.
Motor overheats.	<ol style="list-style-type: none"> 1. Motor overloaded. 2. Improper cooling. (Air circulation restricted through motor due to sawdust, accumulating inside of saw). 	<ol style="list-style-type: none"> 1. Feed work slower into blade. 2. Clean out sawdust to provide normal air circulation through motor. See "Maintenance and Lubrication" section.
Starting switch in motor will not operate.	<ol style="list-style-type: none"> 1. Burned switch contacts (due to extended hold-in periods caused by low line voltage, etc.) 2. Shorted capacitor (when equipped) 3. Loose or broken connections. 	<ol style="list-style-type: none"> 1. Have switch replaced and request a voltage check from the power company. 2. Test capacitor and replace if defective. 3. Have wiring checked and repaired.
Motor stalls (resulting in blown fuses or tripped circuit breakers).	<ol style="list-style-type: none"> 1. Starting switch not operating. 2. Voltage too low to permit motor to reach operating speed. 3. Fuses or circuit breakers do not have sufficient capacity. 	<ol style="list-style-type: none"> 1. Have switch replaced. 2. Request voltage check from the power company. 3. Install proper size fuses or circuit breakers.
Frequent opening of fuses or circuit breakers.	<ol style="list-style-type: none"> 1. Motor overloaded. 2. Fuses or circuit breakers do not have sufficient capacity. 3. Starting switch not operating (motor does not reach speed). 	<ol style="list-style-type: none"> 1. Feed work slower into blade. 2. Install proper size fuses or circuit breakers. 3. Have switch replaced.

**PARTS LIST FOR CRAFTSMAN 10 INCH TABLE SAW
MODEL NO. 113.298720**

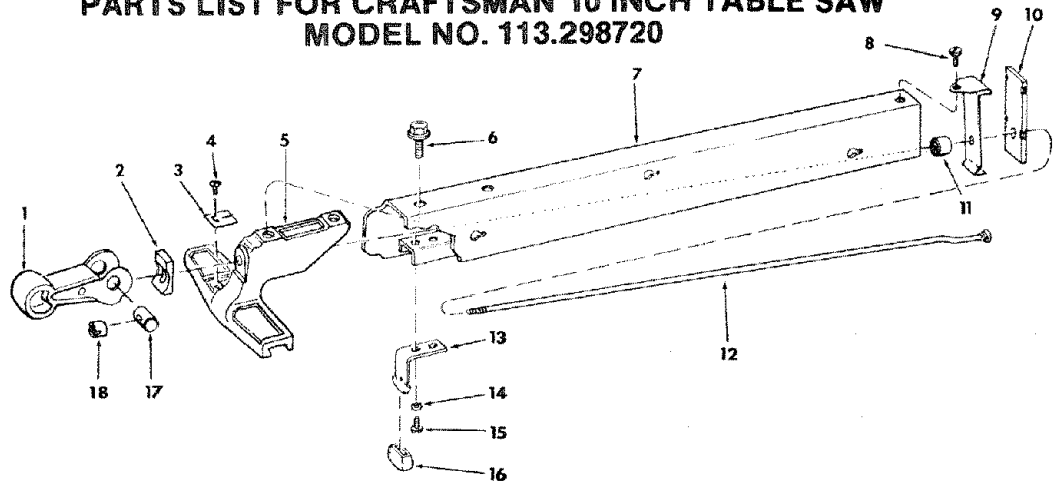

FIGURE 1 - RIP FENCE ASSEMBLY 62952

Key No.	Part No.	Description
1	62942	Handle
2	62945	Shoe
3	62775	Indicator
4	9404336	Screw, Pan Cross Type "T" No. 4-40 x 1/4
5	62941	Head, Fence
6	423567	Screw, Sems 3/8-16 x 1/2
7	62946	Channel, Fence
8	STD600805	*Screw, Pan Cross Type "T" 8-32 x 1/2
9	62528	Spring, Fence Lock

Key No.	Part No.	Description
10	62529	Lock, Rear Fence
11	62531	Roller, Rear Fence
12	62944	Rod, Fence Lock
13	62533	Spring, Head Alignment (Includes Key #18)
14	STD551210	*Lockwasher, External No. 10
15	STD611005	*Screw, Hex Head Type "A" No. 10 x 1/2
16	62532	Pad, Alignment
17	62940	Cam
18	62943	Nut, Adjustment

* Standard Hardware Item - May be purchased locally.

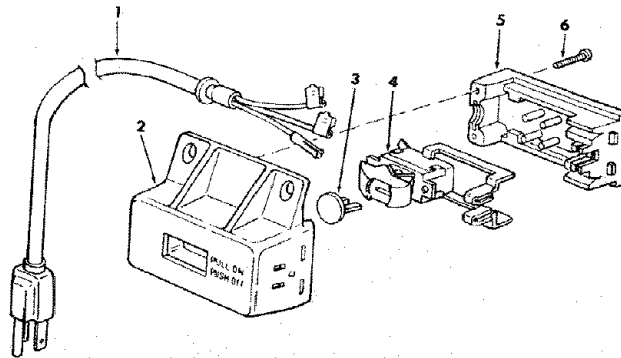

FIGURE 2 - ON/OFF POWER OUTLET 60381

Key No.	Part No.	Description
—	60381	• On/Off Power Outlet Complete
1	60375	Cord, Molded
2	60380	Housing, Switch
3	60256	Key, Switch
4	60374	Switch, Locking
5	60377	Cover, Switch
6	448007	Screw, Pan Hd. No. 6 x 3/4

• Does Not Include Key No. 3
Order Separately If Required.

**PARTS LIST FOR CRAFTSMAN 10 INCH TABLE SAW
MODEL NO. 113.298720**

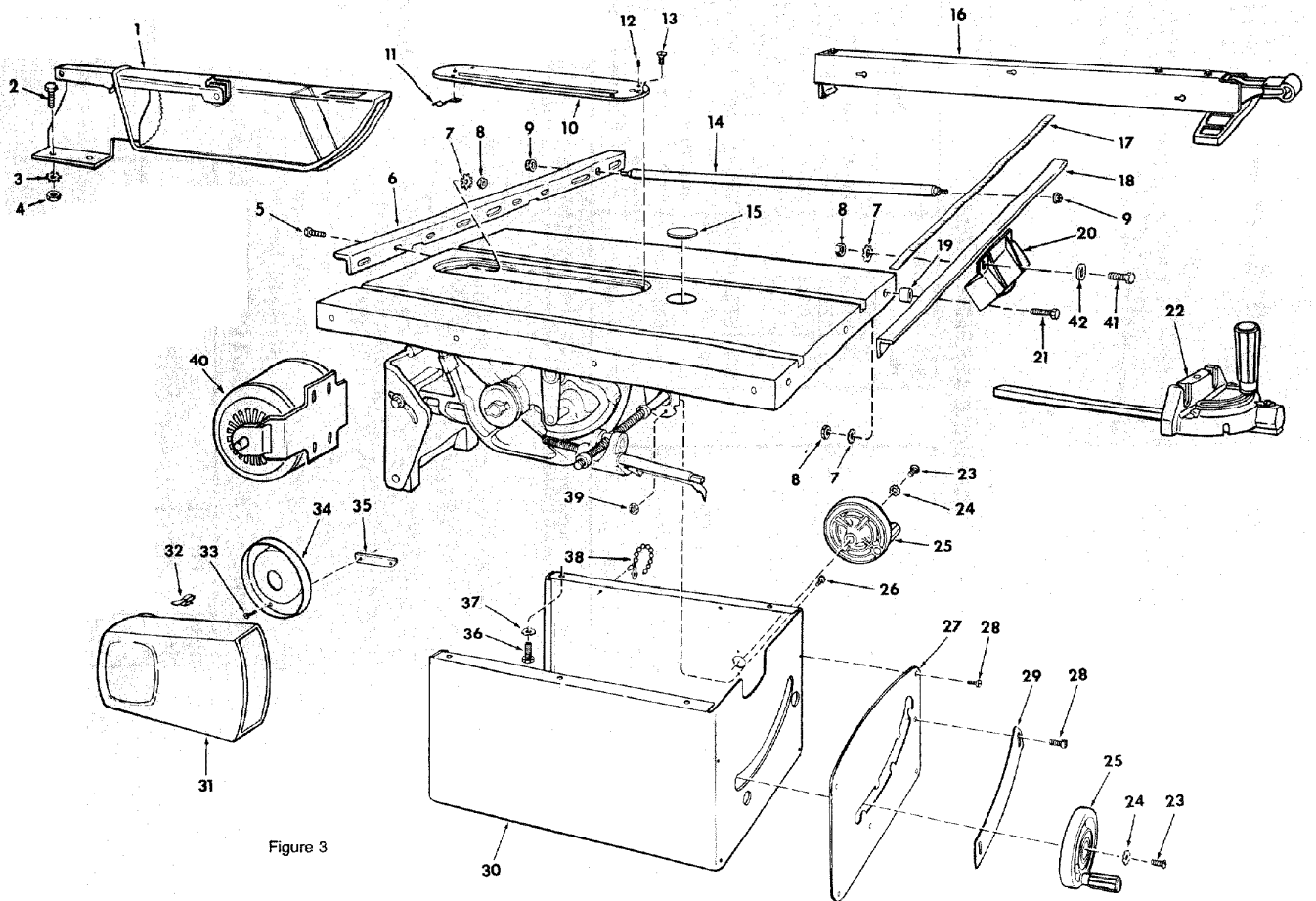

Figure 3

**PARTS LIST FOR CRAFTSMAN 10 INCH TABLE SAW
MODEL NO. 113.298720**

Always order by Part Number – not by Key Number.

FIGURE 3 PARTS LIST

Key No.	Part No.	Description
1	62579	Guard Assembly (See Fig. 6)
2	STD522506	*Screw, Hex Hd. 1/4-20 x 5/8
3	STD551225	*Lockwasher, External 1/4
4	STD541025	*Nut, Hex 1/4-20
5	STD523110	*Screw, Hex 5/16-18 x 1
6	62541	Bar, Fence Rear
7	STD551231	*Lockwasher, External 5/16
8	STD541031	*Nut, Hex 5/16-18
9	60313	Nut, Self-threading
10	62703	Insert Assembly, (Includes Key No. 11 & 12)
11	62718	Clip, Retaining
12	STD501102	*Screw, Locking Set 10-32 x 3/16
13	133645	Screw, Flat Hd. 10-32 x 1
14	62584	Rod, Separation
15	62493	Insert, Exact-I-Cut
16	62952	Fence Assembly, Rip (See Fig. 1)
17	62710	Tape, Fence
18	62709	Bar Assembly, Fence Guide (Includes Key No. 17)
19	62539	Spacer, Fence Guide Bar
20	60381	Switch Assembly Box (See Fig. 2)
21	STD523117	*Screw, Hex 5/16-18 x 1-3/4
22	62704	Gauge Assembly, Miter (See Fig. 5)
23	STD511107	*Screw, Pan Hd. 10-32 x 3/4

Key No.	Part No.	Description
24	STD551210	*Lockwasher, External No. 10
25	62689	Handwheel Assembly
26	STD511103	*Screw, Pan Hd. 10-32 x 3/8
27	62701	Panel, Front
28	STD610805	*Screw, Pan Hd. Ty "AB" No. 8 x 1/2
29	62702	Scale, Adjustable Bevel
30	62700	Base
31	60252	Guard, Belt
32	60255	Clip, "S"
33	STD601105	*Screw, Pan Hd. Ty "T" 10-32 x 1/2
34	60253	Support, Belt Guard
35	60254	Bracket, Support
36	454896	*Screw, Hex Hd. 3/8-16 x 1/2
37	STD551237	*Lockwasher, External 3/8
38	71165	Tie, Wire
39	STD541411	Nut, Lock 10-32
40	62618	+Motor
41	STD522507	*Screw, Hex Hd. 5/16-18 x 3/4
42	STD551031	*Washer, 21/64 x 5/8 x 1/16
	62750	Bag of Loose Parts (Not Illustrated) (Includes Bag 62751)
	62751	Bag of Loose Parts (Not Illustrated)
	SP5116	Owners Manual (Not Illustrated)

* Standard Hardware Item – May Be Purchased Locally.

NOTE: Shipping and handling charges for standard hardware items (identified by *) such as nuts, screws, washers, etc., make buying these items by mail uneconomical. To avoid shipping and handling charges, you may obtain most of these locally.

+ Stock Item – May be secured through the hardware department of most Sears Retail Stores or Catalog Order Houses.

**PARTS LIST FOR CRAFTSMAN 10 INCH TABLE SAW
MODEL NO. 113.298720**

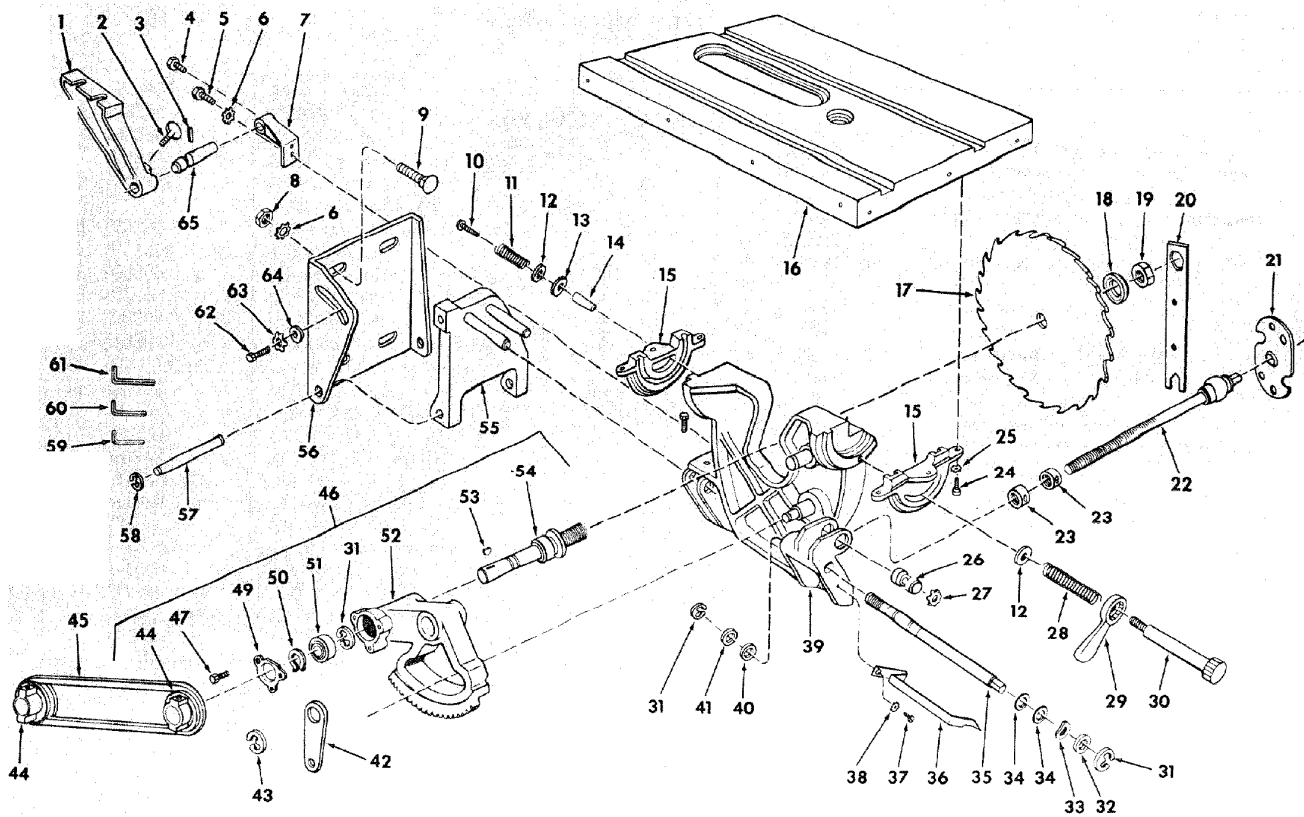

Figure 4

**PARTS LIST FOR CRAFTSMAN 10 INCH TABLE SAW
MODEL NO. 113.298720**

FIGURE 4 PARTS LIST

Key No.	Part No.	Description
1	62587	Support, Spreader
2	60204	Screw, Thumb 5/16-18 x 1
3	STD 571812	*Pin, Roll 3/16 x 1-1/4
4	STD 523106	*Screw, Hex Hd. 5/16-18 x 5/8
5	STD 523110	*Screw, Hex Hd. 5/16-18 x 1
6	STD 551231	*Lockwasher, External 5/16
7	62292	Support, Guard
8	STD 541031	*Nut, Hex 5/16-18
9	STD 532507	*Bolt, Carriage 5/16-18 x 3/4
10	60206	*Screw, Hex Ind. Wash. Hd. 1/4-20 x 1-1/2
11	60205	Spring
12	STD 551037	*Washer, 380 x 47/64 x 3/32
13	63011	Washer, Knob Clamp
14	62295	Spacer
15	30426	Table, Trunnion
16	62696	Table, 10 In. Saw
17	60175	+Blade, Saw 10 In.
18	62498	Collar, Blade
19	6362	Nut, Arbor
20	3540	Wrench, Arbor
21	62437	Retainer, Bearing
22	62698	Screw, Tilt
23	37900	Collar, Stop
24	STD 523710	*Screw, Hex Hd. 3/8-16 x 1
25	STD 551237	*Lockwasher, External 3/8
26	37899	Nut, Tilt
27	63054	Ring, Retaining 3/4
28	37828	Spring, Clamp Screw
29	18	Handle, Clamp Screw
30	37829	Screw, Clamp
31	STD 581062	*Ring, Retaining 5/8
32	37838	Washer .629 x 7/8 x 1/64
33	60178	Washer, Spring

* Standard Hardware Item -- May Be Purchased Locally.

Key No.	Part No.	Description
34	STD 302111	*O-Ring
35	62697	Screw, Lift
36	62699	Pointer
37	STD 601103	*Screw, Pan Hd. Ty "T" 10-32 x 3/8
38	STD 551210	*Lockwasher, External No. 10
39	62489	Cradle (Includes Key No's. 42 and 43)
40	30509	Washer, End Play (.005 Thick)
41	30767	Washer, End Play (.010 Thick)
42	62312	Link
43	6527	Ring, Retaining 3/4
44	STD 328022	*Pulley, 5/8 Bore (Includes Set Screw)
45	STD 304410	*Belt, V 1/2 x 41
46	30419	Housing, Arbor Assembly (Includes Key No's. 44, 47, 49, 50, 51, 52, 53, 54)
47	STD 600803	*Screw, Pan Hd. Ty "T" 8-32 x 3/8
49	3508	Retainer, Arbor Bearing
50	37158	Ring, Retaining 5/8
51	3509	Bearing, Saw Arbor
52	30420	Housing, Arbor
53	STD 580025	*Key, Woodruff
54	6532	Arbor (Includes Key No's. 31, 50, 53)
55	37825	Support, Motor Base
56	37824	Base, Motor
57	37823	Pin, Hinge
58	STD 581037	Ring, Retaining 3/8
59	37836	Wrench, Hex L 3/32
60	37887	Wrench, Hex L 1/8
61	37837	Wrench, Hex L 5/32
62	30628	Screw, Pivot Arm
63	6423	Washer, Spring
64	STD 551025	*Washer, 17/64 x 47/64 x 1/16
65	62585	Rod, Spreader

+ Stock Item -- May be secured through the Hardware Department of most Sears Retail Stores or Catalog Order Houses.

**PARTS LIST FOR CRAFTSMAN 10 INCH TABLE SAW
MODEL NO. 113.298720**

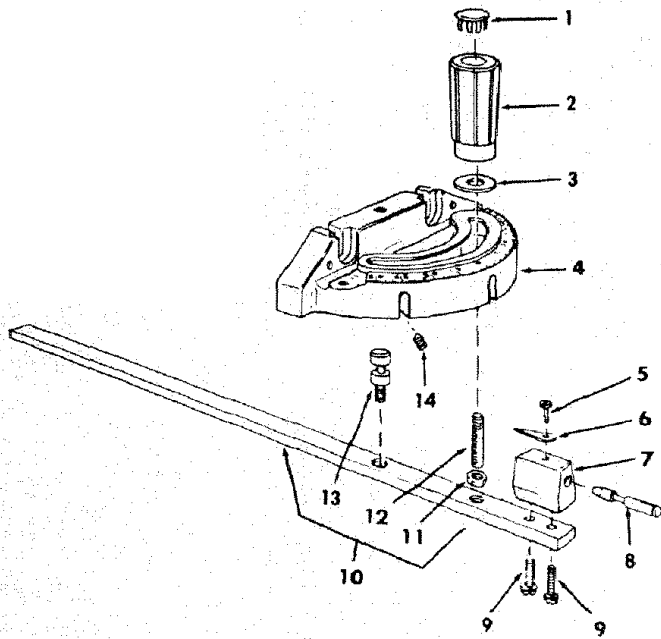

FIGURE 5 - 62704 MITER GAUGE ASSEMBLY

Key No.	Part No.	Description
—	62704	+Gauge Assembly, Miter
1	62693	Plug, Button
2	62692	Knob, Miter Gauge (Includes Key No. 1)
3	STD 551031	*Washer, Plain, 21/64 x 1 x 1/16
4	37893	Gauge, Miter
5	STD 510803	*Screw, Pan Hd. 8-32 x 5/16
6	135	Indicator
7	37895	Block, Miter Gauge Indicator
8	37896	Pin, Miter Gauge Stop
9	9417295	*Screw, Pan Hd., w/Lockwasher, 8-32 x 5/8
10	62230	Rod Assembly, Miter Gauge, Consisting of Items 11, 12, 13
11	STD 541231	*Nut, Hex., 5/16-18
12	62225	Stud, Clamp
13	62383	Stud, Pivot
14	60288	Screw, Locking Set 1/4-20 x 3/8

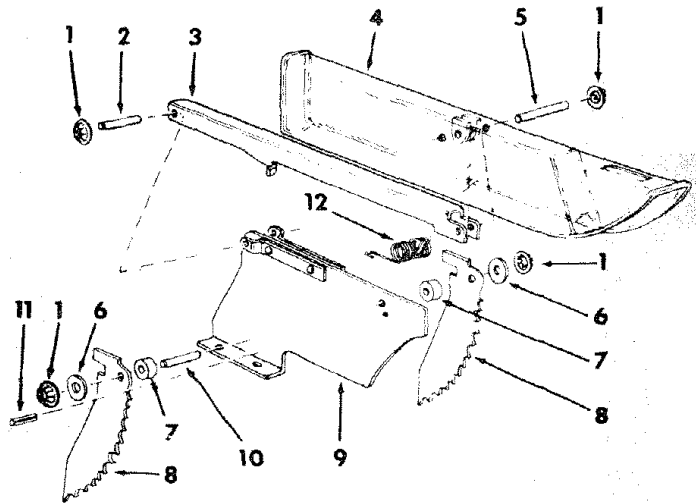

FIGURE 6 - 62579 GUARD ASSEMBLY

Key No.	Part No.	Description
—	62579	Guard Assembly, Saw
1	60297	Nut, Push
2	62391	Pin 1/4 x 1-1/2"
3	62395	Support, Guard
4	62389	Guard, Saw
5	62390	Pin, 1/4 x 1-3/4"
6	STD 551025	*Washer, 17/64 x 5/8 x 1/16"
7	62520	Spacer, Pawl
8	62879	Pawl
9	62580	Spreader, Assembly Blade
10	62410	Pin, 1/4 x 1"
11	STD 571810	*Pin, Roll, 3/16 x 15/16"
12	62519	Spring, Pawl

* Standard Hardware Item — May Be Purchased Locally.

+ Stock Item — May be secured through the Hardware Department of most Sears Retail Stores or Catalog Order Houses.

**PARTS LIST FOR CRAFTSMAN 10 INCH TABLE SAW
MODEL NO. 113.298720**

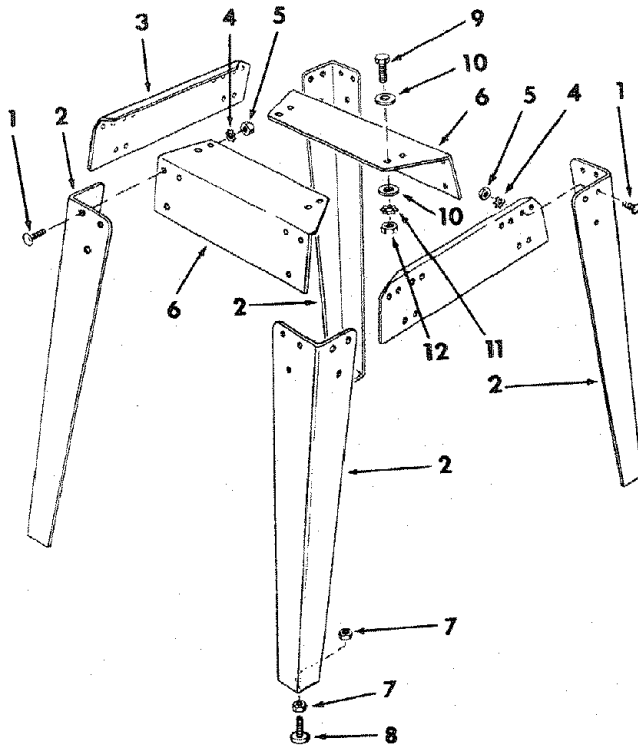

FIGURE 7 - LEGS

Key No.	Part No.	Description
1	60314	Screw, Serrated Truss Hd. 1/4-20 x 5/8
2	62552	Leg
3	62554	Stiffener, Side
4	STD 551225	*Lockwasher, Ext. 1/4
5	STD 541025	*Nut, Hex 1/4-20
6	62553	Stiffener, End
7	STD 541250	*Nut, Hex 1/2-13
8	803835	Foot, Leveling
HARDWARE FOR ATTACHING LEGS TO SAW.		
9	STD 523112	*Screw, Hex Hd. 5/16-18 x 1-1/4
10	STD 551031	Washer, 11/32 I.D.
11	STD 551131	*Lockwasher, Ext. 5/16
12	STD 541031	*Nut, Hex 5/16-18
	62752	Bag of Loose Parts (not illustrated)

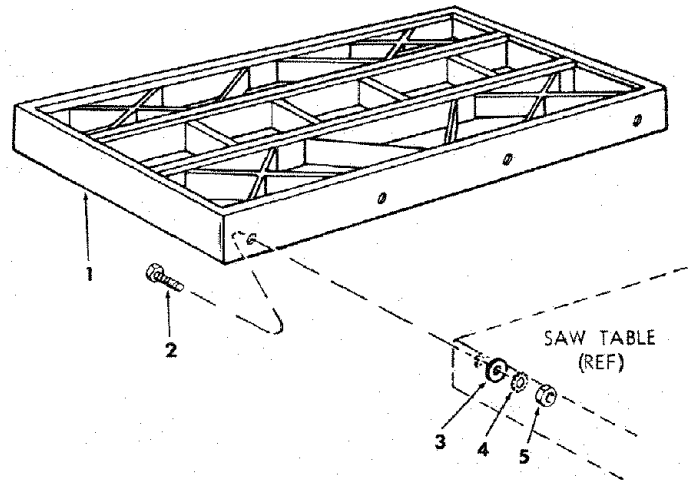

FIGURE 8 - TABLE EXTENSIONS

Key No.	Part No.	Description
1	62947	Extension, Table 12 x 27
2	STD523112	*Screw, Hex Hd. 5/16-18 x 1-1/4
3	STD551031	*Washer, 11/32 x 11/16 x 1/16
4	STD551131	*Lockwasher, External 5/16
5	STD541031	*Nut, Hex 5/16-18
—	507780	Bag of Loose Parts (Not Illus.)

* Standard Hardware Item - May be purchased locally

* Standard Hardware Items — May be Purchased Locally.

† Stock Item — May be secured through the Hardware Department of most Sears retail stores or catalog order house.

SEARS

*owners
manual*

SERVICE

**MODEL NO.
113.298720**

**HOW TO ORDER
REPAIR PARTS**

10 INCH TABLE SAW

Now that you have purchased your 10-inch table saw should a need ever exist for repair parts or service, simply contact any Sears Service Center and most Sears, Roebuck and Co. stores. Be sure to provide all pertinent facts when you call or visit.

The model number of your 10-inch table saw will be found on a plate attached to your saw, at the left-hand side of the base.

WHEN ORDERING REPAIR PARTS, ALWAYS GIVE THE FOLLOWING INFORMATION:

PART NUMBER	PART DESCRIPTION
MODEL NUMBER 113.298720	NAME OF ITEM 10-INCH TABLE SAW

All parts listed may be ordered from any Sears Service Center and most Sears stores. If the parts you need are not stocked locally, your order will be electronically transmitted to a Sears Repair Parts Distribution Center for handling.

Sold by SEARS, ROEBUCK AND CO., Chicago, IL. 60684 U.S.A.