

14" Wood Cutting Band Saw

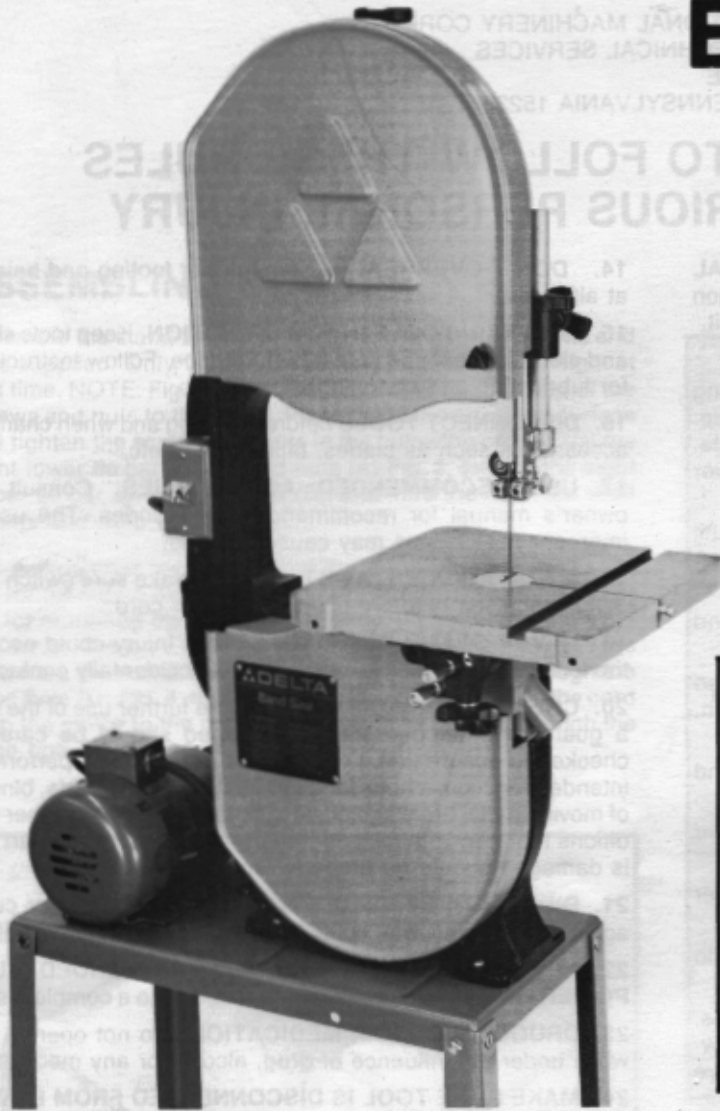

The Serial No./Model No. plate is attached to the right side of the base casting. Locate this plate and record the Serial No. and Model No. in your manual for future reference.

SERIAL
NO. _____

MODEL
NO. _____

Dated 1-9-89

Part No. 426-02-651-0021
©Delta International Machinery Corp. 1989

SAFETY RULES

As with all machinery there are certain hazards involved with operation and use of the machine. Using the machine with respect and caution will considerably lessen the possibility of personal injury. However, if normal safety precautions are overlooked or ignored, personal injury to the operator may result.

This machine was designed for certain applications only. Delta Machinery strongly recommends that this machine NOT be modified and/or used for any application other than for which it was designed. If you have any questions relative to its application DO NOT use the machine until you have written Delta Machinery and we have advised you.

DELTA INTERNATIONAL MACHINERY CORP.
MANAGER OF TECHNICAL SERVICES
246 ALPHA DRIVE
PITTSBURGH, PENNSYLVANIA 15238

WARNING: FAILURE TO FOLLOW THESE RULES MAY RESULT IN SERIOUS PERSONAL INJURY

- 1. FOR YOUR OWN SAFETY, READ INSTRUCTION MANUAL BEFORE OPERATING THE TOOL.** Learn the tool's application and limitations as well as the specific hazards peculiar to it.
- 2. KEEP GUARDS IN PLACE** and in working order.
- 3. GROUND ALL TOOLS.** If tool is equipped with three-prong plug, it should be plugged into a three-hole electrical receptacle. If an adapter is used to accommodate a two-prong receptacle, the adapter lug must be attached to a known ground. Never remove the third prong.
- 4. REMOVE ADJUSTING KEYS AND WRENCHES.** Form habit of checking to see that keys and adjusting wrenches are removed from tool before turning it "on."
- 5. KEEP WORK AREA CLEAN.** Cluttered areas and benches invite accidents.
- 6. DON'T USE IN DANGEROUS ENVIRONMENT.** Don't use power tools in damp or wet locations, or expose them to rain. Keep work area well-lighted.
- 7. KEEP CHILDREN AND VISITORS AWAY.** All children and visitors should be kept a safe distance from work area.
- 8. MAKE WORKSHOP CHILDPROOF** - with padlocks, master switches, or by removing starter keys.
- 9. DON'T FORCE TOOL.** It will do the job better and be safer at the rate for which it was designed.
- 10. USE RIGHT TOOL.** Don't force tool or attachment to do a job for which it was not designed.
- 11. WEAR PROPER APPAREL.** No loose clothing, gloves, neckties, rings, bracelets, or other jewelry to get caught in moving parts. Nonslip foot wear is recommended. Wear protective hair covering to contain long hair.
- 12. ALWAYS WEAR EYE PROTECTION.** Refer to ANSI Z87.1 Standard for appropriate recommendations. Also use face or dust mask if cutting operation is dusty.
- 13. SECURE WORK.** Use clamps or a vise to hold work when practical. It's safer than using your hand and frees both hands to operate tool.
- 14. DON'T OVERREACH.** Keep proper footing and balance at all times.
- 15. MAINTAIN TOOLS IN TOP CONDITION.** Keep tools sharp and clean for best and safest performance. Follow instructions for lubricating and changing accessories.
- 16. DISCONNECT TOOLS** before servicing and when changing accessories such as blades, bits, cutters, etc.
- 17. USE RECOMMENDED ACCESSORIES.** Consult the owner's manual for recommended accessories. The use of improper accessories may cause hazards.
- 18. AVOID ACCIDENTAL STARTING.** Make sure switch is in "OFF" position before plugging in power cord.
- 19. NEVER STAND ON TOOL.** Serious injury could occur if the tool is tipped or if the cutting tool is accidentally contacted.
- 20. CHECK DAMAGED PARTS.** Before further use of the tool, a guard or other part that is damaged should be carefully checked to ensure that it will operate properly and perform its intended function - check for alignment of moving parts, binding of moving parts, breakage of parts, mounting, and any other conditions that may affect its operation. A guard or other part that is damaged should be properly repaired or replaced.
- 21. DIRECTION OF FEED.** Feed work into a blade or cutter against the direction of rotation of the blade or cutter only.
- 22. NEVER LEAVE TOOL RUNNING UNATTENDED. TURN POWER OFF.** Don't leave tool until it comes to a complete stop.
- 23. DRUGS, ALCOHOL, MEDICATION.** Do not operate tool while under the influence of drug, alcohol or any medication.
- 24. MAKE SURE TOOL IS DISCONNECTED FROM POWER SUPPLY** while motor is being mounted, connected or reconnected.
- 25. WARNING:** The dust generated by certain woods and wood products can be injurious to your health. Always operate machinery in well ventilated areas and provide for proper dust removal. Use wood dust collection systems whenever possible.

ADDITIONAL SAFETY RULES FOR BAND SAWS

- 1. ADJUST** the upper guide about 1/8" above the material being cut.
- 2. MAKE SURE** that blade tension and blade tracking are properly adjusted.
- 3. STOP** the machine before removing scrap pieces from the table.
- 4. ALWAYS** keep hands and fingers away from blade.
- 5. CHECK** for proper blade size and type.
- 6. DO NOT** attempt to saw stock that does not have a flat surface, unless a suitable support is used.
- 7. HOLD** material firmly and feed into blade at a moderate speed.
- 8. TURN OFF** machine if the material is to be backed out of an uncompleted cut.
- 9. MAKE** "release" cuts before cutting long curves.
- 10.** Additional information regarding the safe and proper operation of this product is available from the National Safety Council, 444 N. Michigan Avenue, Chicago, IL 60611 in the Accident Prevention Manual for Industrial Operations and also in the Safety Data Sheets provided by the NSC. Please also refer to the American National Standards Institute ANSI 01.1 Safety Requirements for Woodworking Machinery and the U.S. Department of Labor OSHA 1910.213 Regulations.

UNPACKING AND CLEANING

Carefully unpack the band saw, stand, and all loose items from the cartons. Remove the protective coating from the machined surfaces of the band saw. This coating may be removed with a soft cloth moistened with kerosene (do not use acetone, gasoline or lacquer thinner for this purpose). After cleaning, cover all unpainted surfaces with a good quality paste wax.

TOOLS NEEDED FOR ASSEMBLY

Your band saw can be assembled using a few basic hand tools including:

Screwdriver
Phillips screwdriver
7/16" Wrench

1/2" Wrench
9/16" Wrench
Hex Key (Allen) Wrench

ASSEMBLING STAND

Assemble the stand as shown in Fig. 2, using the 24 screws and nuts supplied. Only tighten the screws and nuts finger tight at this time. NOTE: Fig. 3 illustrates the proper relationship of the screws and nuts to the stand. Place the stand on a level surface and tighten the screws and nuts in the following order. First the eight lower tie bar screws and nuts (A) Fig. 2, second the eight upper tie bar screws and nuts (B), and third the eight top shelf screws and nuts (C).

Fig. 4, illustrates the top shelf of the stand. The four holes (A) are for mounting the band saw to the stand. The four holes (B) are for mounting the motor to the stand. If you are using the 62-142 motor, the cord from the motor to the power supply and the cord from the motor to the switch are to be passed through the large hole (D) Fig. 4. If you are using the 62-246 motor, the cord from the motor to the power supply is to be passed through the large hole (D) Fig. 4.

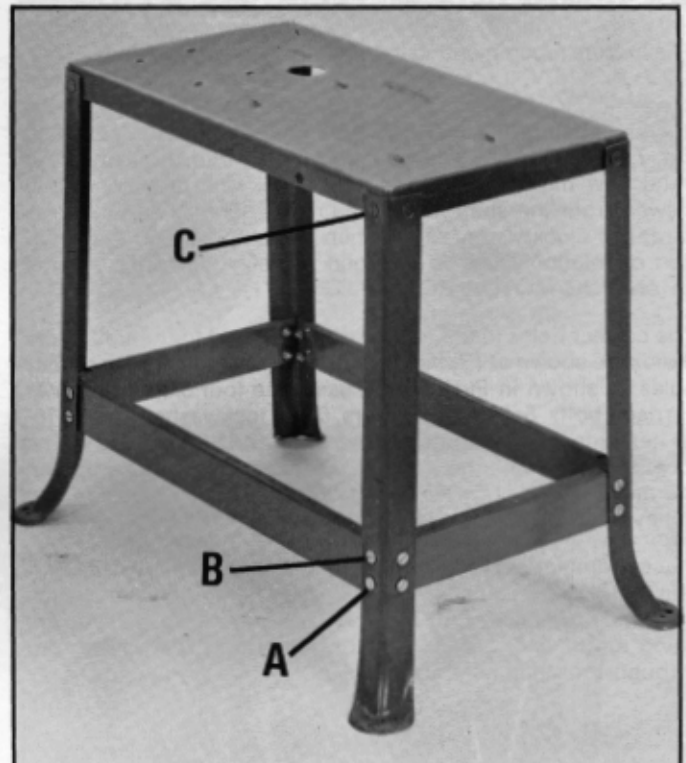

Fig. 2

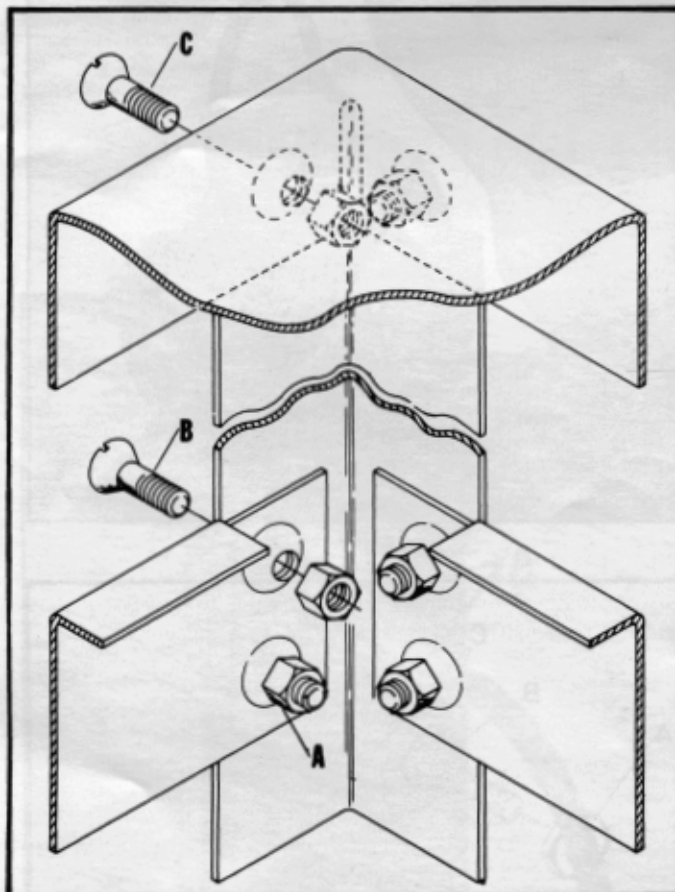

Fig. 3

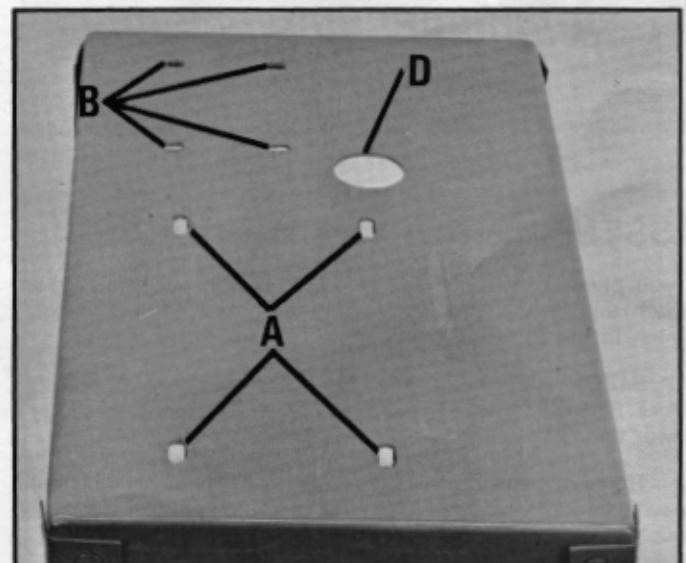

Fig. 4

ASSEMBLING BAND SAW TO STAND

The correct holes in the top shelf of the stand for mounting the band saw are shown at (A) Fig. 4. Assemble the band saw to the stand, as shown in Fig. 5, using the four 5/16-18 x 1-3/4" hex head screws, 5/16" flat washers, 5/16" lockwashers and 5/16" - 18 hex nuts. The hex nuts and lockwashers will be located on the underside of the top shelf.

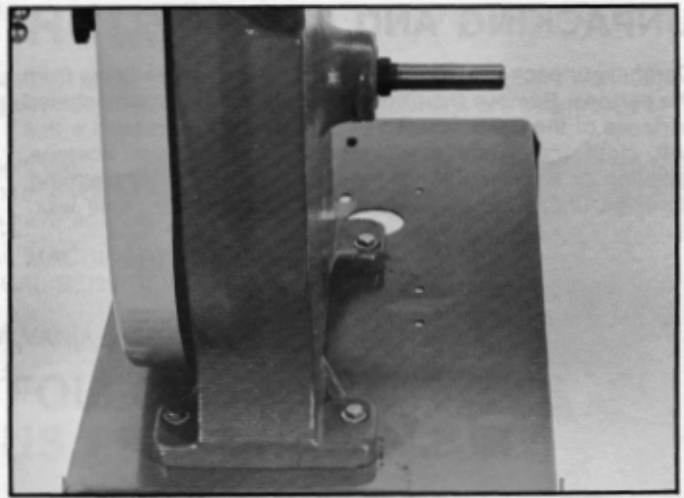

Fig. 5

ASSEMBLING MOTOR TO STAND

The motors recommended for use with your saw are the 62-142, 1/2 H.P., 115 Volt, heavy duty, ball bearing, 1725 RPM motor, shown in Fig. 6, or the 62-246, 3/4 H.P., 115/230 Volt, heavy duty, ball bearing, 1725 RPM, resilient mount motor, shown in Fig. 7. **IMPORTANT:** The rotation of the motor used with your band saw must be in the counterclockwise direction when viewed from the shaft end of the motor. The 62-142 motor is wired for clockwise rotation when it is shipped and the direction of rotation must be changed by referring to the section **CHANGING MOTOR ROTATION OF THE 62-142 MOTOR.**

The correct holes in the top shelf of the stand for mounting the motor are shown at (B) Fig. 4. Assemble the motor to these four holes as shown in Figs. 6 or 7, using the four 5/16 - 18 x 3/4" carriage bolts, 5/16" flat washers, 5/16" lockwashers and 5/16-18 hex nuts. The hex nuts, lockwashers and flat washers will be located underneath the shelf. **NOTE:** Do not completely tighten the motor mounting nuts at this time. Proper belt tension and pulley alignment must first be made.

Place grommet (A) in large hole on top shelf, as shown in Fig. 6 and 7. If you are using the 62-142, 1/2 H.P. motor, insert switch cord and power cord through hole, as shown in Fig. 6. If you are using the 62-246, 3/4 H.P. motor, insert only the power cord through the hole, as shown in Fig. 7.

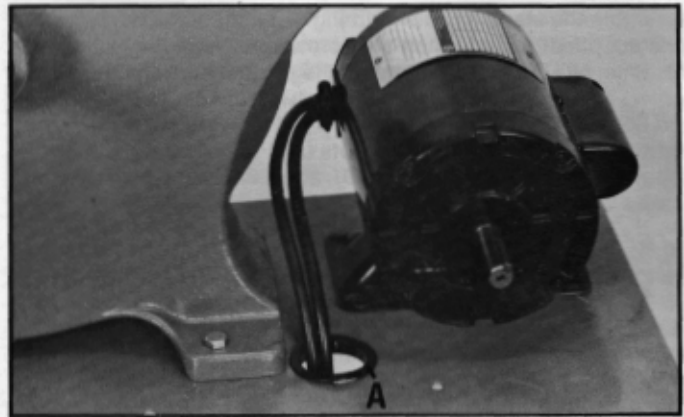

Fig. 6

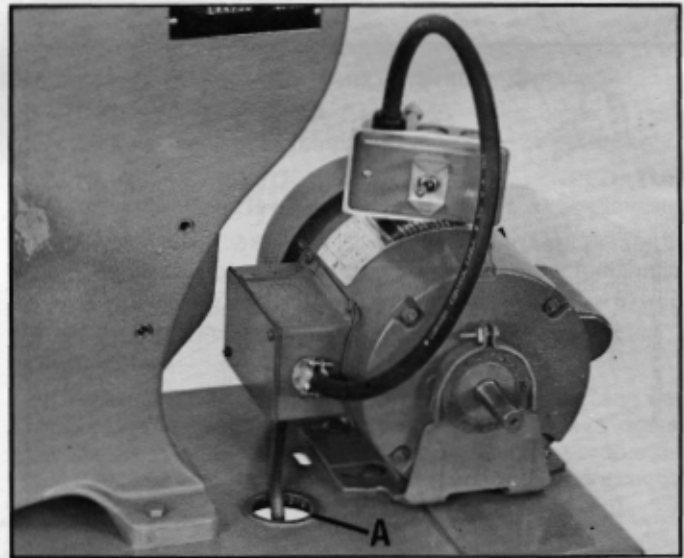

Fig. 7

ASSEMBLING SWITCH

If you purchased the 62-142, 1/2 H.P. motor, you received a switch and cord set connected to the motor. Assemble the switch to the stand as follows:

1. **IMPORTANT:** When assembling the switch to the stand, **MAKE SURE** the motor power cord is **NOT** connected to the power source.

2. Remove the outer hex nut (A) Fig. 8, from the switch stem. Leave external tooth lockwasher (B) and inside hex nut (C) on switch stem. **CAUTION:** The proper grounding of the switch to prevent shock hazard, depends on the use of the external tooth lockwasher in the manner shown.

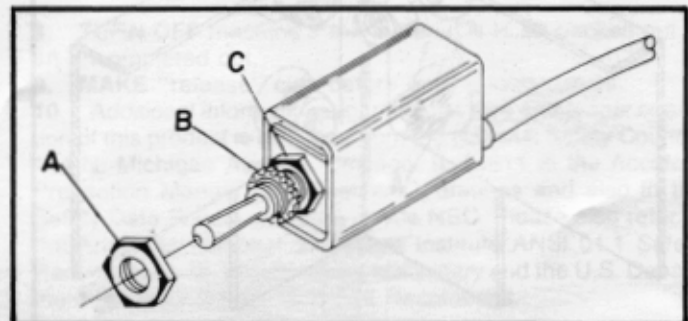

Fig. 8

3. Insert switch stem through hole in the side of top shelf of the stand making sure the key way in the switch stem is in the down position.

4. Place the switch bracket (D) Fig. 9, on switch stem with key of switch bracket engaged with key way in switch stem. Fasten switch in place with hex nut (A) that was removed in Step 2. NOTE: The excess wire from the motor to the switch should be wrapped and tied and then positioned out of the way.

5. **IMPORTANT:** It is recommended that when the band saw is not in use, the switch be locked in the "OFF" position using a padlock. Catalog No. 49-031 Padlock is available as an accessory.

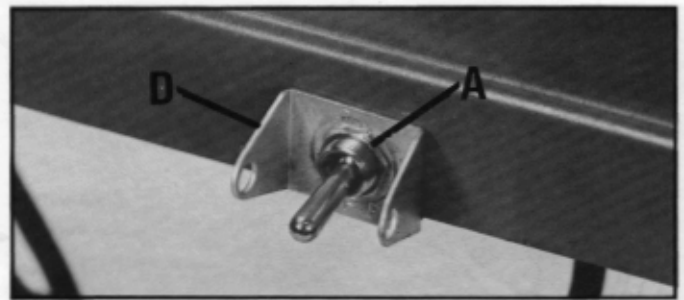

Fig. 9

If you purchased the 62-246 3/4 H.P., motor, you received a switch mounted in a switch box and a cord set connected to the motor. Assemble the switch to the band saw arm, as follows:

1. **IMPORTANT:** When assembling the switch to the band saw arm MAKE SURE the motor power cord is NOT connected to the power source.

2. Remove the two outer nuts, lockwashers and flat washers (A) Fig. 10, from the two screws extending out from the back of the switch box (B).

3. Insert the two screws (C) Fig. 11, located on back of switch box, into the two holes (D) located in the band saw arm.

4. Fasten the switch box to the band saw arm using the two nuts, lockwashers and flat washers (A) Fig. 12, which were removed in STEP 2.

5. Fig. 13, illustrates the switch box (E) assembled to the band saw arm.

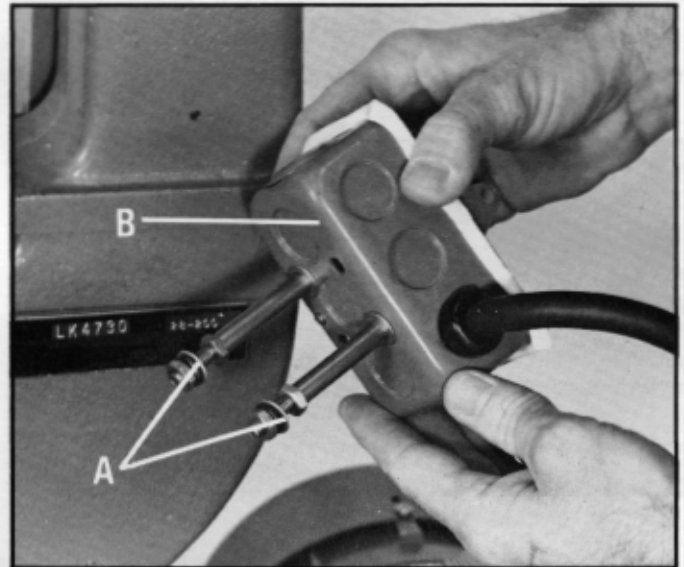

Fig. 10

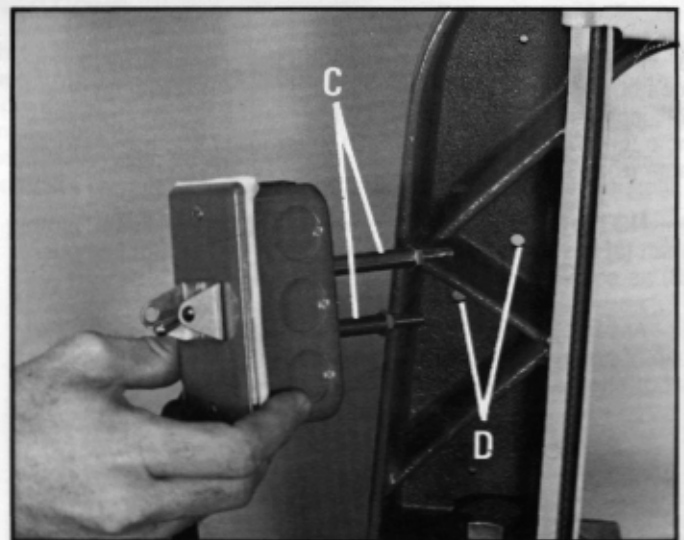

Fig. 11

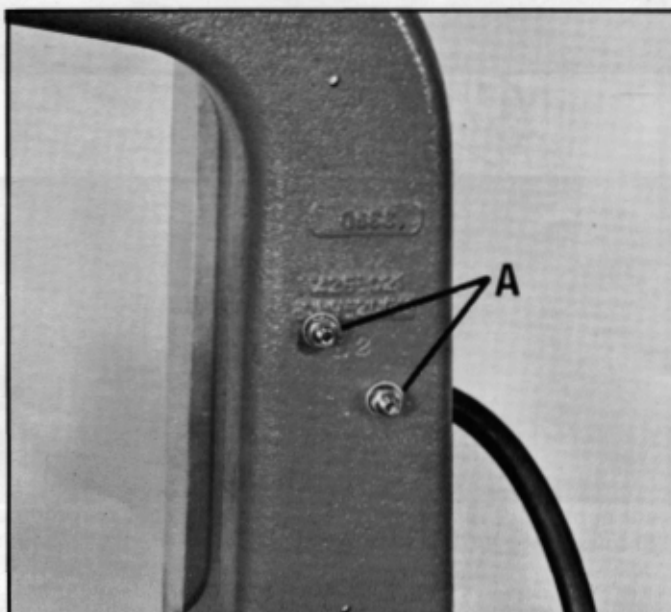

Fig. 12

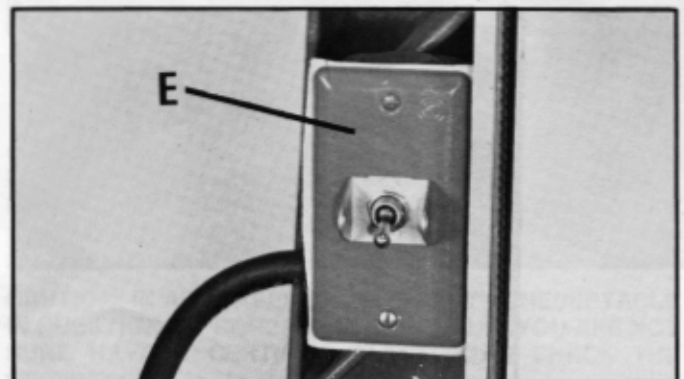

Fig. 13

ASSEMBLING BELT GUARD, MOTOR AND ARBOR PULLEYS AND DRIVE BELT

1. Thread the six self-tapping screws (A) Fig. 14, about half way into the six holes provided in the ledge of the inside belt and pulley guard (B) as shown.

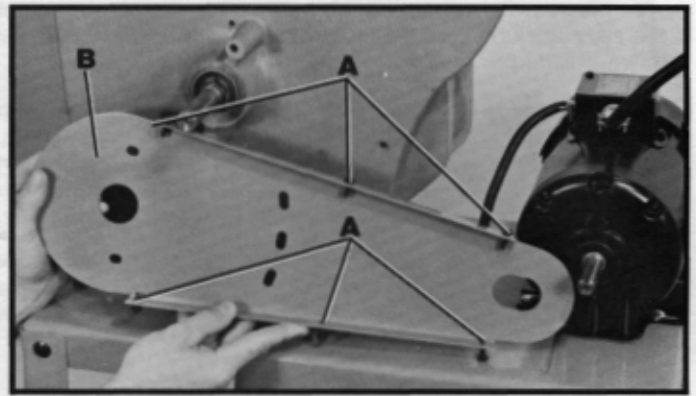

Fig. 14

2. Assemble the inside belt and pulley guard (B) Fig. 15, over the arbor and motor shafts as shown and fasten the guard to the machine using the two 1/2-inch long hex head cap screws and flat washers (C). NOTE: Do not completely tighten the screws at this time.

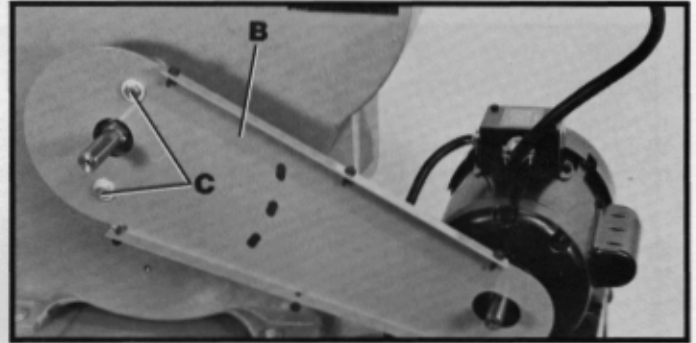

Fig. 15

3. Place the spacer (D) Fig. 16, into the countersunk hole (E) located behind the belt and pulley guard (B). Then insert the 2 3/4-inch hex head cap screw with flat washer (F) into the center hole (G), through the spacer (D) and thread it into the tapped hole (E).

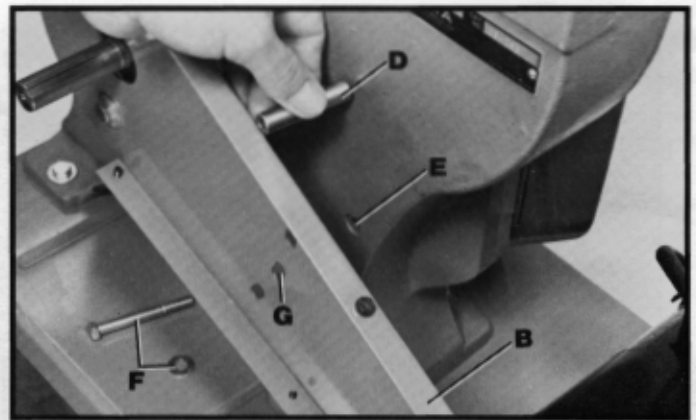

Fig. 16

4. NOTE: Make certain the arbor shaft (H) Fig. 17, and motor shaft (J) are centered in the holes of the belt and pulley guard (B) as shown, then tighten screws (C) and (F).

5. Assemble the arbor pulley (K) Fig. 18, to arbor shaft with hub of pulley in the "out" position. Insert key (L) in keyway of arbor shaft and tighten set screw (M).

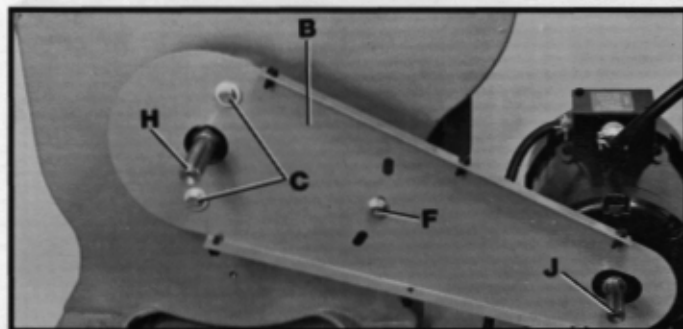

Fig. 17

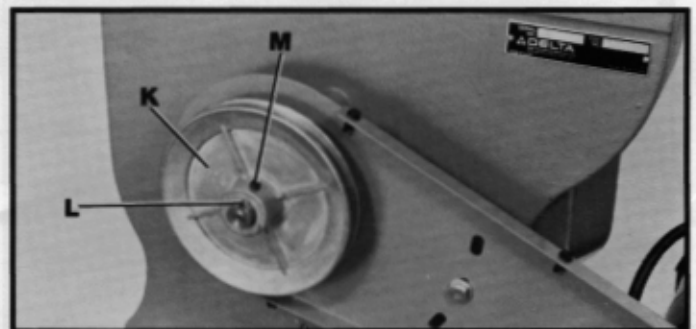

Fig. 18

6. Assemble motor pulley (N) Fig. 19, to motor shaft with hub of pulley in the "in" position. Insert key (P) in keyway of motor shaft and tighten set screw (R) in motor pulley.

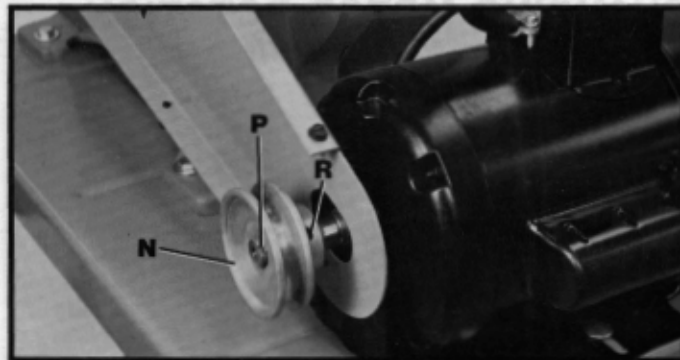

Fig. 19

7. Assemble drive belt (S) Fig. 20 to the arbor pulley and motor pulley as shown. Using a straight edge, check to see if the arbor pulley (K) and the motor pulley (N) are aligned. If an adjustment is necessary, both pulleys can be moved in or out to obtain proper alignment. Adjust for proper belt tension by moving the motor in or out by loosening four mounting bolts, two of which are shown at (T). Correct belt tension is obtained when there is approximately 1/2 inch deflection at the center span of the belt (S) Fig. 20, using light finger pressure. NOTE: When proper belt tension is obtained and both pulleys are aligned, make certain to tighten all mounting hardware.

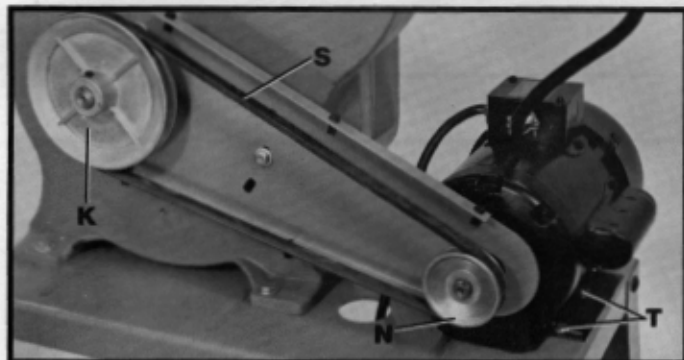

Fig. 20

8. Assemble outer belt and pulley guard (V) to the inside belt and pulley guard and tighten the six screws, three of which are shown at (A) Fig. 21.

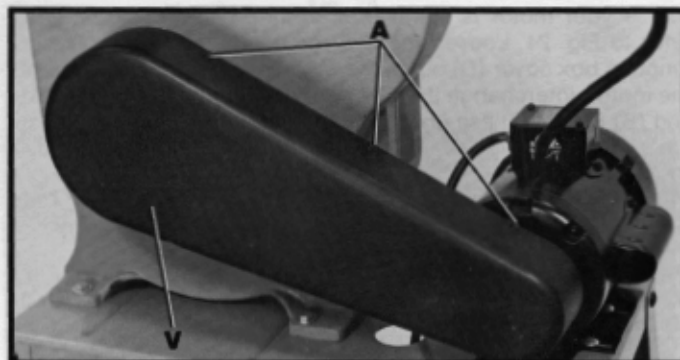

Fig. 21

CONNECTING BAND SAW TO POWER SOURCE

POWER CONNECTIONS

A separate electrical circuit should be used for your power tools. This circuit should not be less than #12 wire and should be protected with a 20 Amp time lag fuse. If an extension cord is used, use only 3-wire extension cords which have 3-prong grounding type plugs and 3-pole receptacles which accept the tools plug. For distances up to 100 feet use #12 wire. For distances up to 150 feet use #10 wire. Before connecting the motor to the power line, make sure the switch is in the "OFF" position and be sure that the electric current is of the same characteristics as stamped on motor nameplate. All line connections should make good contact. Running on low voltage will injure the motor. Have a registered electrician replace or repair damaged or worn cords immediately.

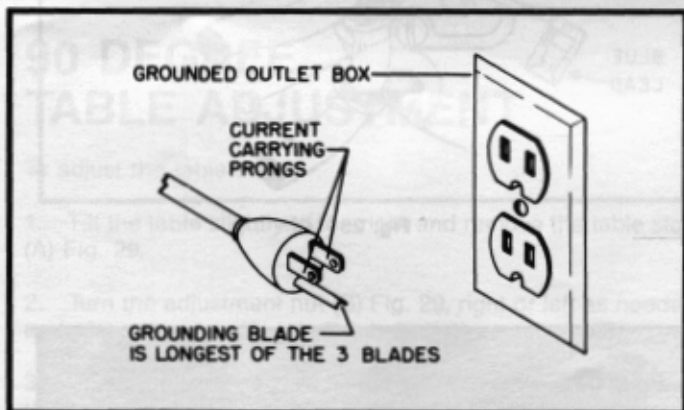

Fig. 22

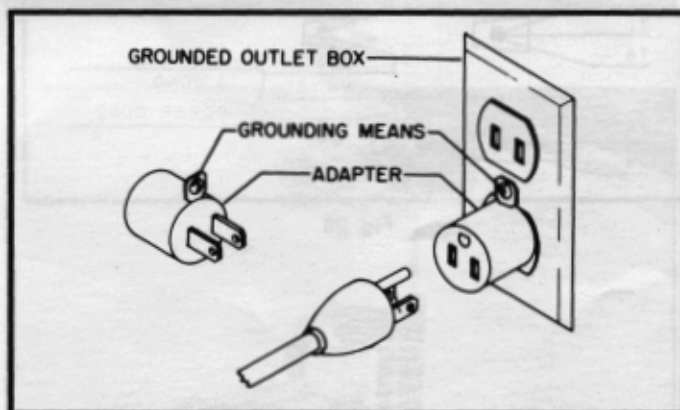

Fig. 23

GROUNDING INSTRUCTIONS

CAUTION: This tool must be grounded while in use to protect the operator from electric shock. The recommended motors are shipped wired for 115 Volt, Single Phase and are equipped with an approved 3-conductor cord and 3-prong grounding type plug to fit the proper grounding type receptacle, as shown in Fig. 22. The green conductor in the cord is the grounding wire. **CAUTION: Never connect the green wire to a live terminal.**

An adapter, shown in Fig. 23, is available for connecting 3-prong

grounding type plugs to 2-prong receptacles. **THIS ADAPTER IS NOT APPLICABLE IN CANADA.** The green-colored rigid ear, lug, etc., extending from the adapter is the grounding means and must be connected to a permanent ground such as to properly grounded outlet box, as shown in Fig. 23.

CAUTION: IN ALL CASES, MAKE SURE THE RECEPTACLE IN QUESTION IS PROPERLY GROUNDED. IF YOU ARE NOT SURE HAVE A CERTIFIED ELECTRICIAN CHECK THE RECEPTACLE.

CHANGING MOTOR ROTATION OF THE 62-142 MOTOR

The rotation of the motor used with your band saw must be in the counterclockwise direction when viewed from the shaft end of the motor. The Delta motor, Cat. No. 62-142, is wired for clockwise direction when it is shipped and the direction of rotation can be changed as follows:

1. Connect the motor to a power source and turn the motor switch on. Check to see the direction of rotation of the motor shaft when viewed from the shaft end. If the direction of rotation is clockwise the motor rotation must be reversed as follows:
2. Make sure the motor is disconnected from the power source and check the motor nameplate to identify the manufacture of the motor.
3. If your motor is manufactured by Emerson Electric Co., refer to Fig. 24. Loosen the two screws (C) and rotate motor junction box cover (D) out of the way. To reverse the rotation of the motor, interchange the black and red leads on terminals (A) and (B) Fig. 24. These leads have spade type terminal clips that are slipped off the terminals (A) and (B) and interchanged.
4. If your motor is manufactured by Marathon Electric, refer to Fig. 25. Loosen two screws (C) and remove the motor junction box cover (D). To reverse the rotation of the motor, interchange the black and blue leads on terminals (A) and (B) Fig. 25. These leads have spade type terminal clips that are slipped off the terminals (A) and (B) and interchanged.
5. If your motor is manufactured by Leeson Electric Corporation, refer to Fig. 26. To reverse the rotation of the motor, interchange motor leads T5 and T8.

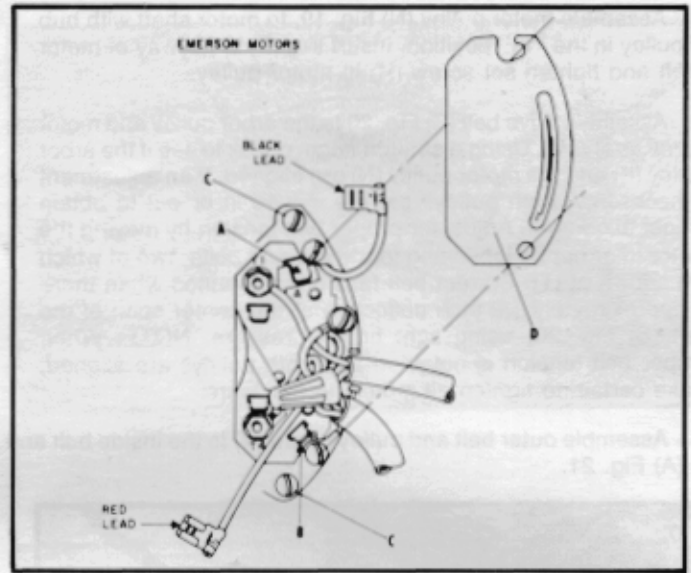

Fig. 24

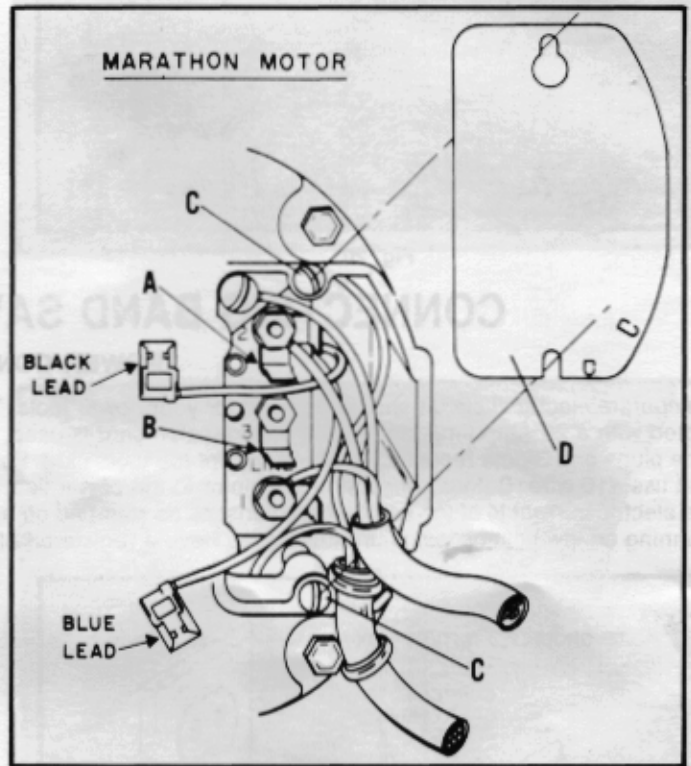

Fig. 25

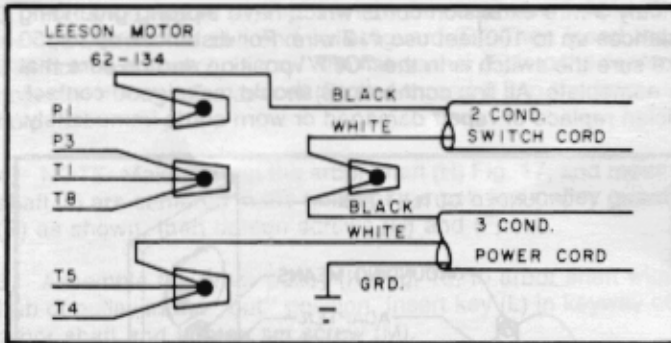

Fig. 26

TABLE INSERT

Place table insert (A) Fig. 27, in the hole provided in the table making sure the pin (B) in the table engages one of the indents in the table insert.

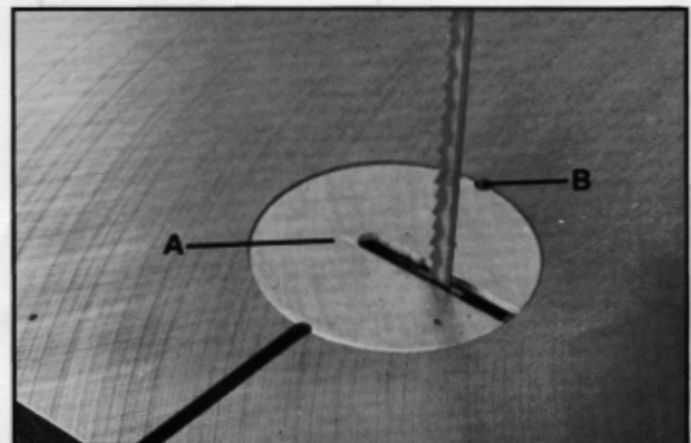

Fig. 27

TILTING THE TABLE

The table on your band saw can be tilted 45 degrees to the right and 10 degrees to the left. To tilt the table, loosen the two star wheels (A) Fig. 28, tilt the table to the desired angle and tighten the two star wheels (A).

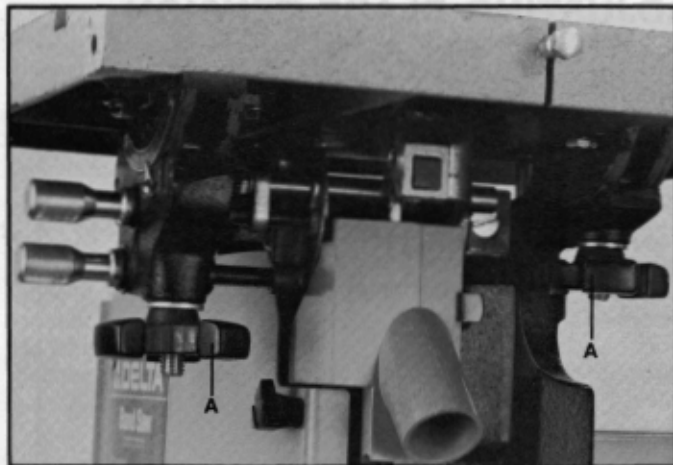

Fig. 28

ASSEMBLING TABLE STOP

The band saw is equipped with an adjustable table stop that allows the table to be set perfectly at 90 degrees with the blade.

To assemble the table stop, tilt the table to the right slightly. Thread the 5/16" - 18 nut (B) Fig. 29 onto the 2-1/2" table stop (A) and insert the stop into the untapped hole in the casting (C) as shown.

Tilt the table to the left until the stop contacts the bottom of the table. Place a square on the table and against the blade as shown in Fig. 30 and check if the blade is 90 degrees with the table surface. If an adjustment is necessary, proceed as follows:

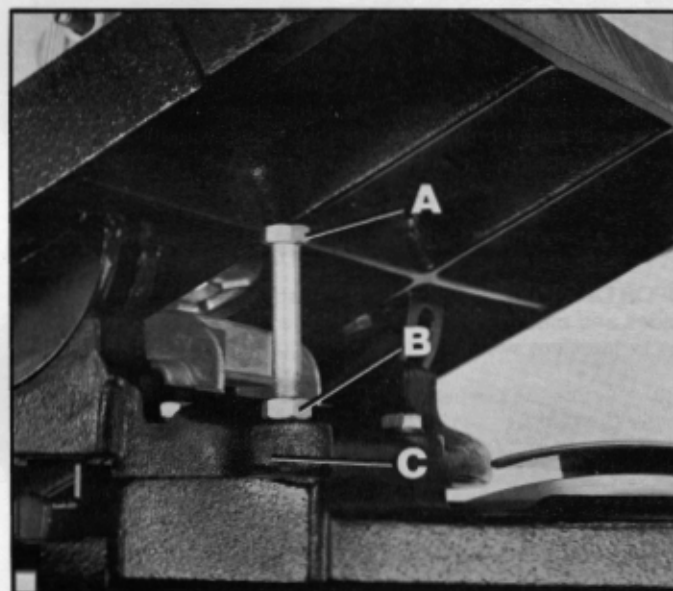

Fig. 29

90 DEGREE TABLE ADJUSTMENT

To adjust the table stop:

1. Tilt the table slightly to the right and remove the table stop (A) Fig. 29.
2. Turn the adjustment nut (B) Fig. 29, right or left as needed and place the stop (A) into the hole in the casting (C).
3. Lower the table and check to see if the table is 90 degrees to the blade for accuracy, as shown in Fig. 30.
4. It is necessary to remove the adjustable stop (A) Fig. 29 when tilting the table to the left.

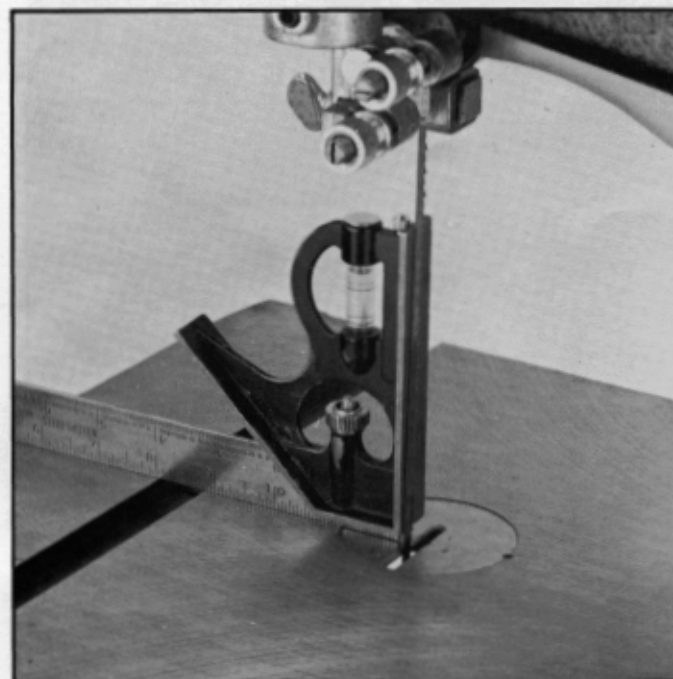

Fig. 30

ADJUSTING BLADE TENSION

On the back of the upper wheel slide bracket there is a series of graduations. These indicate the proper tension for various widths of blades. With the blade on the wheels, turn the knob (A) Fig. 31, to raise or lower the wheel, until the red fiber washer (B) is in line with the proper graduation for the size of blade being used.

The graduations will be found correct for average work, and are not affected by rebrazing of the saw blade. We urge you to use these graduations until you have become familiar enough with the operation of the Band Saw to vary the tension for different kinds of blades or work. Over-straining is a common cause of blade breakage and other unsatisfactory blade performance. Release the tension when the machine is not in use.

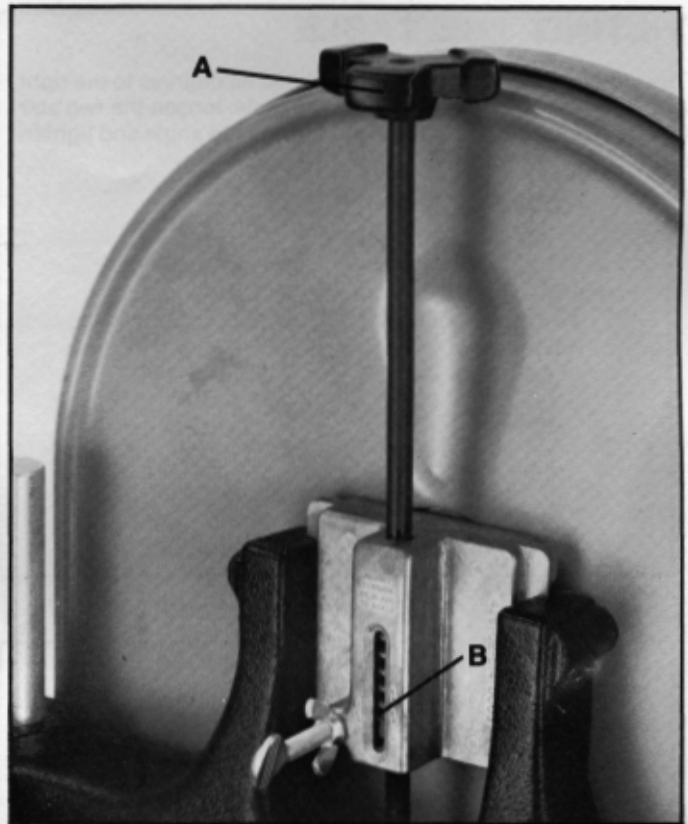

Fig. 31

TRACKING THE BLADE

IMPORTANT: Before tracking the blade, make sure the blade guides and blade support bearings are clear of the blade so as not to interfere with the tracking adjustment.

After tension has been applied to the blade, revolve the wheels slowly forward by hand and watch the blade (A) Fig. 32, to see that it travels in the center of the upper tire. If the blade begins to creep toward the front edge, loosen the wing nut (B) Fig. 33, and tighten the thumb screw (C). This will tilt the top of the wheel toward the back of the machine and will draw the blade toward the center of the tire. If the blade creeps toward the back edge, turn the thumb screw in the opposite direction. Adjust the thumb screw (C) Fig. 33, only a fraction of a turn at a time. **NEVER TRACK THE BLADE WHILE THE MACHINE IS RUNNING.** After the blade is tracking in the center of the tires, tighten the wing nut (B) Fig. 33.

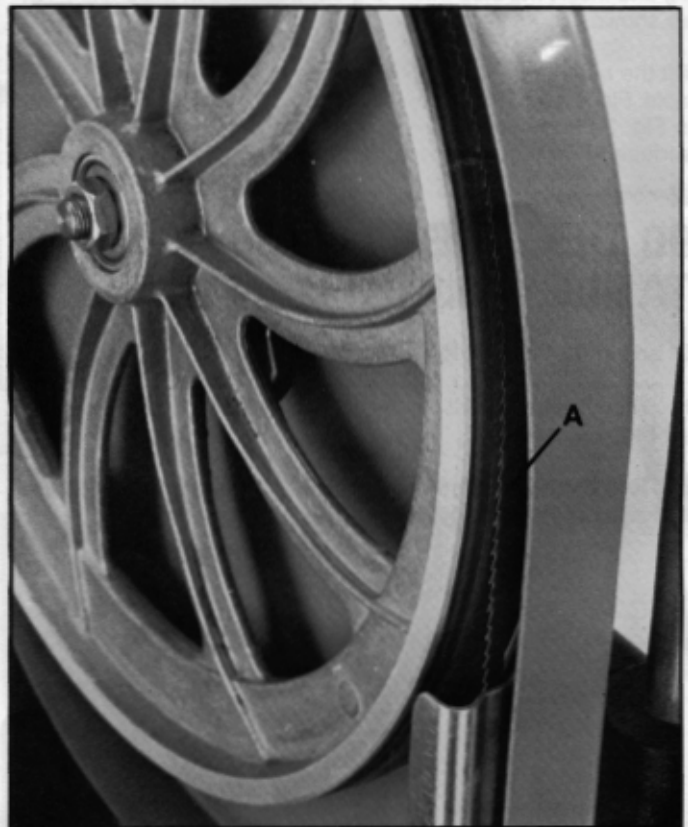

Fig. 32

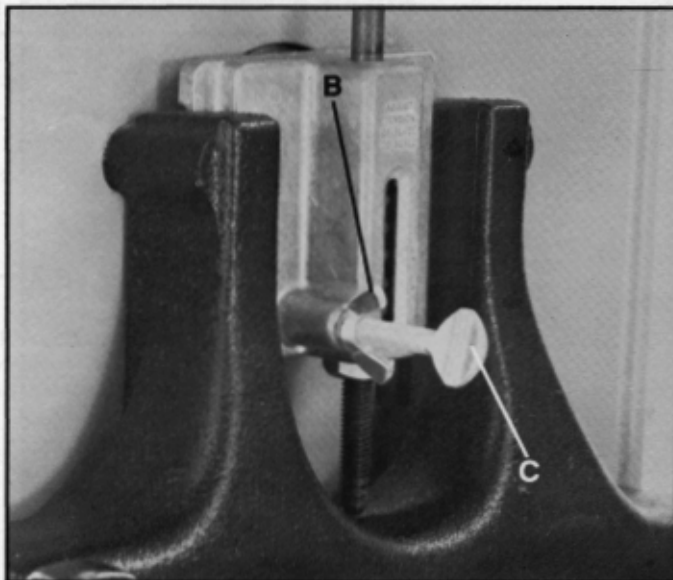

Fig. 33

ADJUSTING UPPER BLADE GUIDE ASSEMBLY

The upper blade guide assembly (A) Fig. 34, should always be set as close as possible to the top surface of the material being cut by loosening lock knob (B) and moving the guide assembly (A) to the desired position.

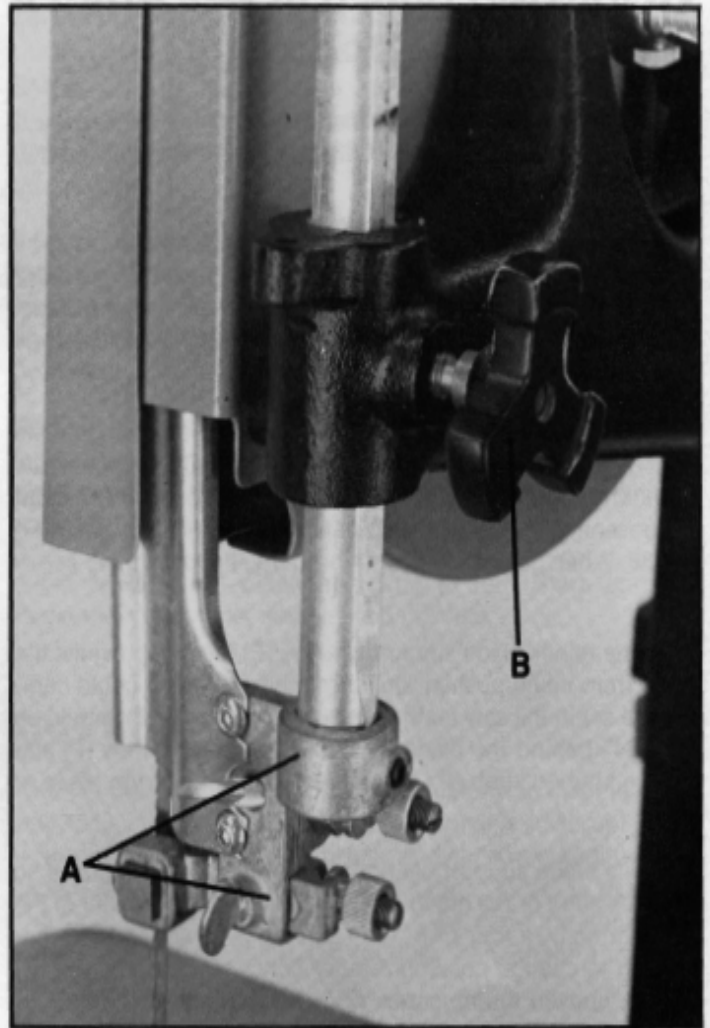

Fig. 34

The upper blade guide assembly should also be adjusted so that the blade guides (A) Fig. 35, are flat with the blade. If an adjustment is necessary, loosen screw (B) and rotate the complete guide assembly (C) until the blade guides are flat with the blade.

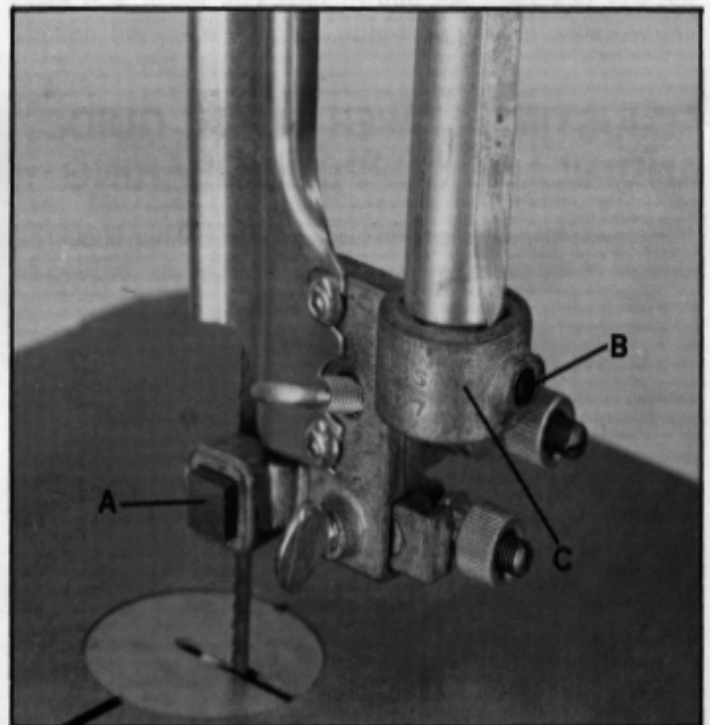

Fig. 35

ADJUSTING UPPER BLADE GUIDES AND BLADE SUPPORT BEARING

The upper blade guides and blade support bearings are adjusted only after the blade is tensioned and tracking properly. To adjust proceed as follows:

1. The upper blade guides (A) Fig. 36, are held in place by means of the set screws (B). Loosen the set screws (B) to move the guides (A) as close as possible to the side of the blade, being careful not to pinch the blade. Then tighten the screws (B).

2. The guides (A) Fig. 36, should then be adjusted so that the front edge of the guides are just behind the "gullets" of the saw teeth. The complete guide block bracket can be moved in or out by loosening thumb screw (C) and turning knurled knob (D) Fig. 36. When guides (A) are set properly, tighten thumb screw (C).

3. The upper blade support bearing (E) Fig. 36, prevents the blade from being pushed too far to the back which could damage the set in the saw teeth. The support bearing (E) should be set $1/64$ " behind the blade by loosening thumb screw (F) and turning knurled knob (G) to move the support bearing (E) in or out.

4. The blade support bearing (E) should also be adjusted so the back edge of the blade overlaps the outside diameter of the ball bearing by about $1/16$ ". The bearing (E) is set on an eccentric and to change position remove screw (H) and bearing (E) Fig. 36. Loosen thumb screw (F), back out screw (G) and reposition shaft that bearing (E) is attached to.

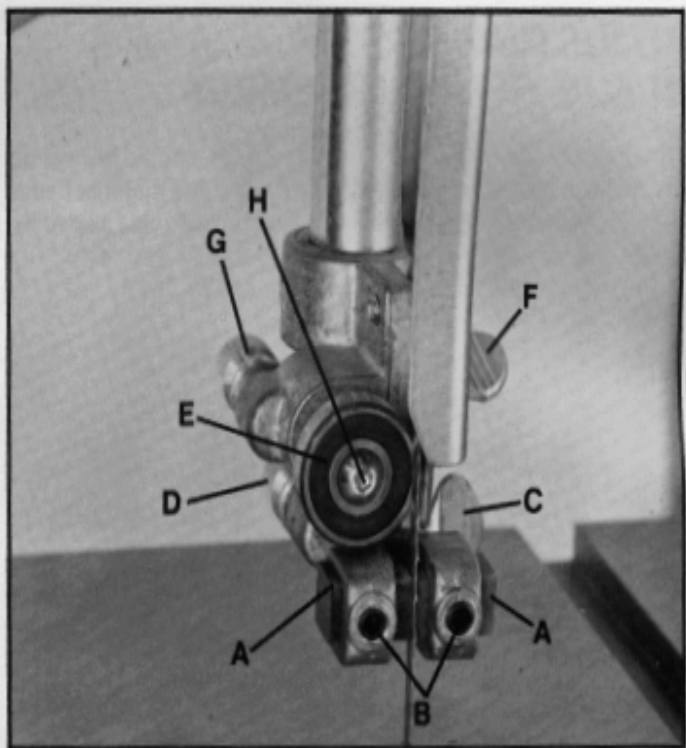

Fig. 36

ADJUSTING LOWER BLADE GUIDES AND BLADE SUPPORT BEARING

The lower blade guides and blade support bearing should be adjusted at the same time as the upper guides and bearing as follows:

1. Loosen the two screws (A) Fig. 37, and move the guides (B) as close as possible to the side of the blade, being careful not to pinch the blade. Then tighten screws (A).

2. The front edge of the guide blocks (B) should be adjusted so they are just behind the "gullets" of the saw teeth by turning the knurled knob (C) Fig. 37.

3. The lower blade support bearing (D) Fig. 37, should be adjusted so it is about $1/64$ " behind the back of the blade by turning the knurled knob (E).

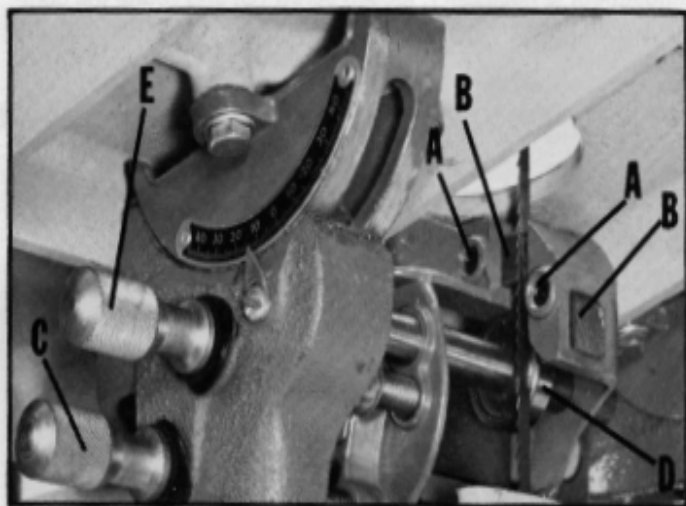

Fig. 37

CHANGING BLADES

To change blades, proceed as follows:

1. Open the upper and lower wheel guards.
2. Release tension on the band saw blade.
3. Remove the table adjustment pin and table insert.
4. Slip the blade off the wheel and guide it out through the slot in the table.
5. To install a new blade, reverse the above procedure.

BAND SAW BLADES

A band saw blade is a delicate piece of steel that is subjected to tremendous strain. You can obtain long use from a band saw blade if you give it fair treatment. Be sure you use blades of the proper thickness, width and temper for the various types of material to be cut.

Always use the widest blade possible. Use the narrow blades only for sawing small, abrupt curves and for fine delicate work. This will save blades and will produce better work. Band saw blades may be purchased, welded, set and sharpened ready for use. For cutting wood and similar materials we can supply them in widths of 1/8, 3/16, 1/4, 3/8, 1/2 and 3/4 inches.

File and set the wood cutting blades whenever you find it requires pressure to make them cut. If a blade is broken it can be brazed or welded; however, if it has become badly work-hardened it will soon break in another place. If you are not equipped to file, set and braze or weld blades, take them to a saw filer for reconditioning.

Any one of a number of conditions may cause a band saw blade to break. Blade breakage is, in some cases, unavoidable, being the natural result of the peculiar stresses to which such blades are subjected. It is, however, often due to avoidable causes, most often to lack of care or judgment on the part of the operator in mounting or adjusting the blade or guides. The most common causes of blade breakage are: (1) faulty alignments and adjustments of the guides, (2) forcing or twisting a wide blade around a curve of short radius, (3) feeding too fast, (4) dullness of the teeth or absence of sufficient set, (5) excessive tightening of the blade, (6) top guide set too high above the work being cut, (7) using a blade with a lumpy or improperly finished braze or weld and, (8) continuous running of the saw blade when not in use for cutting.

New blades for the standard 14 inch Band Saw are 93½ inches long. The adjustment will accommodate blades up to a maximum length of 94 inches and to a minimum length of 91½ inches. When equipped with the No. 28-984 Height Attachment, new blades should be 105 inches long; maximum and minimum lengths are 106 and 103½ inches.

OPERATING THE BAND SAW

Before starting the machine, see that all adjustments are properly made and the guards are in place. Turn the pulley hand to make sure that everything is correct BEFORE turning on the power.

Keep the top guide down close to the work at all times. Do not force the material against the blade too hard. Light contact with the blade will permit easier following of the line and prevent undue friction, heating and work-hardening of the blade at back edge.

KEEP THE SAW BLADE SHARP and you will find that very little forward pressure is required for average cutting. Move the stock against the blade steadily and no faster than will give easy cutting movement.

Avoid twisting the blade by trying to turn sharp corners. Remember, you must saw around corners.

CUTTING CURVES

When cutting curves, turn the stock carefully so that the blade may follow without being twisted. If a curve is so abrupt that it is necessary to repeatedly back up and cut a new kerf, either a narrow blade is needed or a blade with more set is required. The more set a blade has, the easier it will allow the stock to be turned, but the cut is usually rougher than where a medium amount of set is used.

In withdrawing the piece being cut, in order to change the cut or for any other reason, the operator must be careful that the blade does not accidentally draw the blade off the wheels. In most cases it is easier and safer to turn the stock and saw through the waste material, rather than try to withdraw the stock from the blade.

Delta 14" Band Saw Accessories

For 14" Wood Cutting Band Saw

No. 41-033 Motor Pulley, 2 $\frac{3}{4}$ " diameter, $\frac{5}{8}$ " bore. $\frac{1}{2}$ lb.

No. 49-173 V-Belt, 57 $\frac{1}{8}$ " O.C.

For 14" Band Saws



No. 25-858 Lamp Attachment, for 115 V. Includes 9" flexible gooseneck, reflector and 8-foot cord with plug. Uses standard bulb (not included) up to 40 watts. 2 lbs.

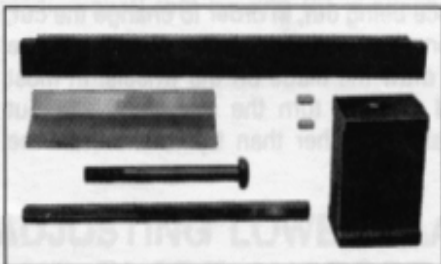

Height Attachment. Increases capacity of 14" Band Saw from 6 $\frac{1}{4}$ " to 12 $\frac{1}{4}$ " under the guide. Add at any time. Needs 105" blades.

No. 28-984 Height Attachment with cast block, dowels and bolt, extension front blade guard, wood back blade guard. 12 lbs.

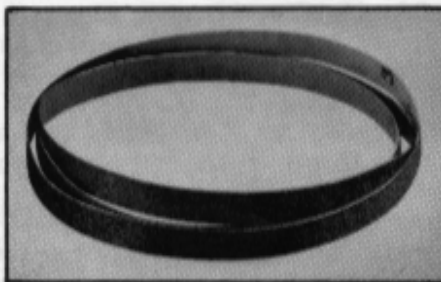

No. 28-836 Sanding Belt. Garnet type, five, No. 80 grit, fine, $\frac{1}{2}$ " wide, 91" long. 1 lb.

No. 28-837 Sanding Belt. Garnet type, five, No. 40 grit, medium, $\frac{1}{2}$ " wide, 91" long. 1 lb.



No. 28-810 Sanding Attachment. Includes flat and curved platens with guides and mounting brackets. 1 lb.

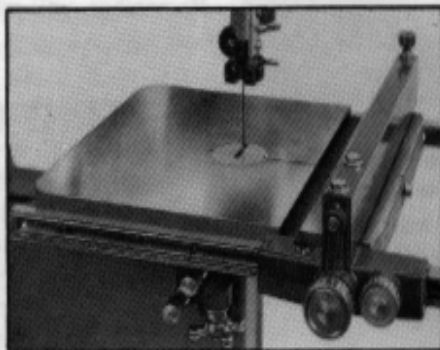

No. 28-843 Rip Fence. With 18" guide bars and mounting screws. 8 lbs.

No. 28-845 Rip Fence. With 32" guide bars and mounting screws. 12 lbs.



No. 34-895 Miter Gage. For straight and angle operations. Has $\frac{3}{8}$ x $\frac{3}{4}$ x 18" guide bar and pivoting work support body with pointer and calibrations reading through 120° swing. Adjustable, positive stops at 90° and 45° positions. 4 lbs.

No. 34-568 Clamp Attachment for Miter Gage. With clamp bar, two sliding clamp screws, and front and rear posts. 1 $\frac{1}{2}$ " lbs.

No. 34-873 Extra Clamp Screw and Block. For Clamp Attachment. $\frac{1}{2}$ lb.

Wood Cutting Band Saw Blades. 93 $\frac{1}{2}$ " blades are standard; 105" blades used with 28-984 Height Attachment. $\frac{1}{2}$ lb.

Number (93 $\frac{1}{2}$ " Long)	Number (105" Long)	Width	Min. Cut. Rad.	Teeth Per In.
28-032	28-045	$\frac{1}{8}$ "	$\frac{1}{4}$ "	12
28-033	28-046	$\frac{3}{16}$ "	$\frac{5}{16}$ "	6
28-034	28-047	$\frac{1}{4}$ "	$\frac{5}{8}$ "	6
28-036	28-048	$\frac{3}{8}$ "	1 $\frac{7}{16}$ "	5
28-038	28-050	$\frac{1}{2}$ "	2 $\frac{1}{2}$ "	5
28-040	28-052	$\frac{3}{4}$ "	5 $\frac{7}{16}$ "	4

Skip Tooth Band Saw Blades

For cutting aluminum, magnesium, plastics and all kinds of wood. All blades are 93 $\frac{1}{2}$ " long. $\frac{1}{2}$ lb.

Number	Width	Minimum Cut. Rad.	Teeth Per In.
28-884	$\frac{1}{4}$ "	$\frac{5}{8}$ "	6
28-885	$\frac{3}{8}$ "	1 $\frac{7}{16}$ "	4
28-886	$\frac{1}{2}$ "	2 $\frac{1}{2}$ "	4

Delta Industrial Distributors

Your local Industrial Distributor, who makes Delta Industrial Machines and Accessories conveniently available to you, also can assist you with expert application engineering. He is as close to you as your phone. He is always willing to help you by making prompt emergency deliveries of hundreds of items which could prevent costly shutdowns and delays. Depend on him for all of your industrial requirements, just as Delta does at all of its plant locations.



Delta maintains a modern, efficient Parts Distribution Center, located in Memphis, Tennessee, maintaining an inventory of over 10,000 parts.

Highly qualified and experienced Customer Service Representatives are standing by to assist you on weekdays from 8:00 A.M. to 5:00 P.M. Memphis time.

MEMPHIS, TN 38118

4290 Raines Road

Phone: (901) 363-8800

~~HOTLINE~~

800-223-PART

(In Tennessee 800-238-PART)



Delta Building Trades and Home Shop Machinery Two Year Limited Warranty

Delta will repair or replace, at its expense and at its option, any Delta machine, machine part, or machine accessory which in normal use has proven to be defective in workmanship or material, provided that the customer returns the product prepaid to a Delta factory service center or authorized service station with proof of purchase of the product within two years and provides Delta with reasonable opportunity to verify the alleged defect by inspection. Delta may require that electric motors be returned prepaid to a motor manufacturer's authorized station for inspection and repair or replacement. Delta will not be responsible for any asserted defect which has resulted from normal wear, misuse, abuse or repair or alteration made or specifically authorized by anyone other than an authorized Delta service facility or representative. Under no circumstances will Delta be liable for incidental or consequential damages resulting from defective products. This warranty is Delta's sole warranty and sets forth the customer's exclusive remedy, with respect to defective products; all other warranties, express or implied, whether of merchantability, fitness for purpose, or otherwise, are expressly disclaimed by Delta.